

THIS COPY IS PROVIDED ON A RESTRICTED BASIS AND IS NOT TO BE USED IN ANY WAY DETRIMENTAL TO THE INTERESTS OF PANDUIT CORP.

CABINET

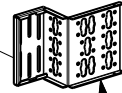
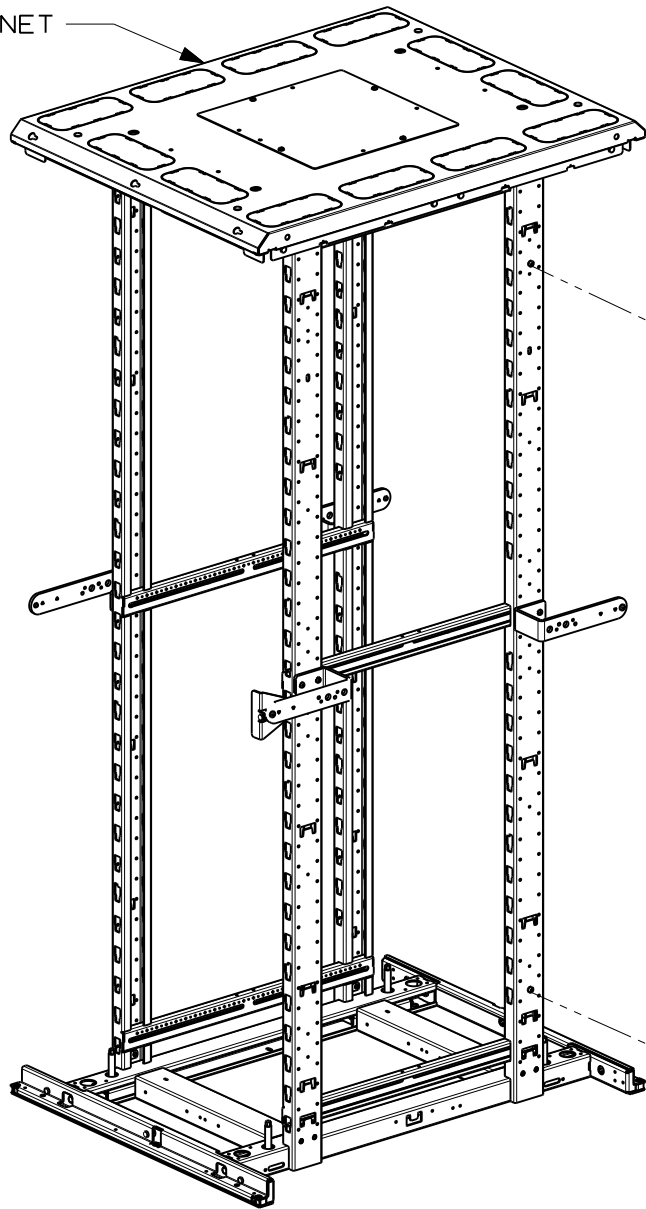

PDU MOUNTING BRACKET

APPLICATION VIEW - CABINET NOT INCLUDED

PANDUIT PART NO.	WEIGHT
CVPDUB	2.7 LBS/EACH 1.2 Kg/EACH

1. VISIT OUR ON-LINE CATALOG AT WWW.PANDUIT.COM FOR A LIST OF CURRENT PARTS APPLICABLE FOR USE WITH THIS PRODUCT.
2. DIMENSIONS IN PARENTHESES
3. PARTS SUPPLIED:
1- PAIR OF PDU MOUNTING BRACKETS
1- HARDWARE KIT
1- INSTRUCTION SHEET
4. FULLY BONDED STRUCTURE WHEN ASSEMBLED PER INSTRUCTIONS.
5. SEE INSTALLATION INSTRUCTIONS CM344** FOR EXACT MOUNTING LOCATIONS.

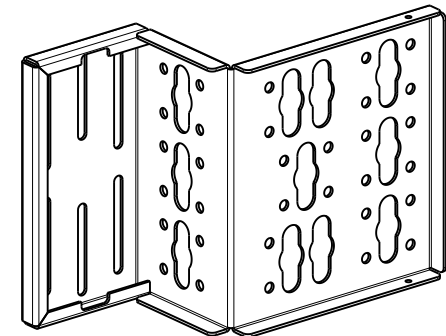

MODEL FILENAME		V10502CU_DC/09.PRT	
CAD FILENAME/LAYERS		V10502CU_DC/09A.PRT	
<h1>PANDUIT</h1> CORP. TINLEY PARK, ILLINOIS			
POU VERTICAL MOUNTING BRACKET (CVPDUB) CUSTOMER DRAWING			
UNLESS OTHERWISE SPECIFIED, DIMENSIONAL TOLERANCES ARE:		UNLESS OTHERWISE SPECIFIED,	
INCHES	[METRIC - MILLIMETER]	ANGLE	
X.X +/- 0.03	X. +/- 0.8	ALL DIMENSIONS ARE GIVEN	
X.XX +/- 0.015	X.X +/- 0.4	IN INCHES, THIRD ANGLE PROJECTION.	
X.XXX +/- 0.005	X.XX +/- 0.13		
DRAWN BY	MAT'L:	SCALE	
MRWA		NONE	
DATE	SEE NOTES	DRAWING NO.	
2-4-11		V10502CU-DC	
CHK'D		SHEET 1 OF 2	
MAY		DWG SIZE	
		A	

REV	DATE	BY	CHK	DESCRIPTION	ECN	R	CUST	SUP	OTH
09A	2-4-11	MRWA	MAY	RELEASED TO PRODUCTION	V10502CU-DC				

THIS COPY IS PROVIDED ON A RESTRICTED BASIS AND IS NOT TO BE USED IN ANY WAY DETRIMENTAL TO THE INTERESTS OF PANDUIT CORP.

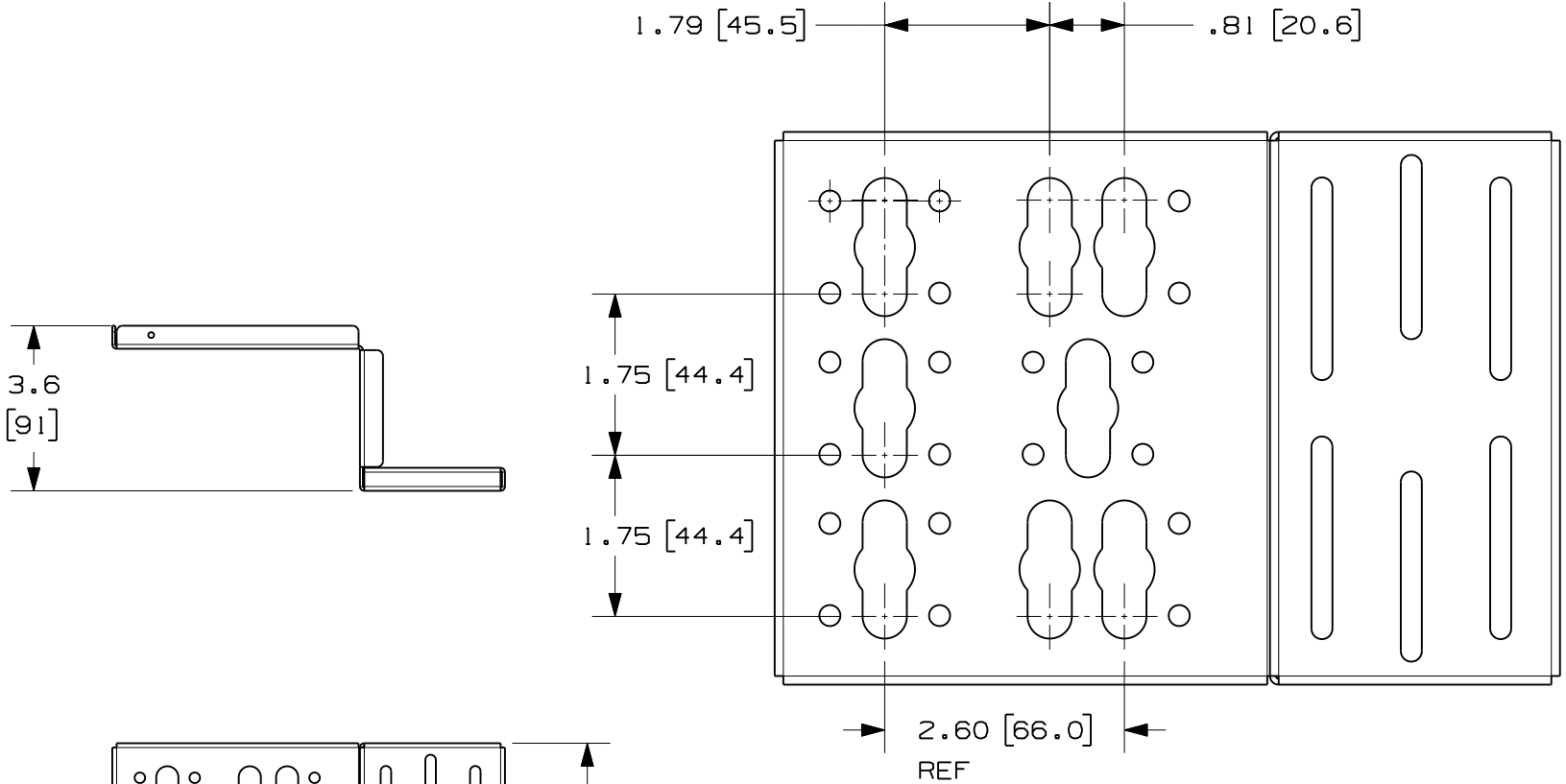

MODEL FILENAME	V10502CU_DC/09.PRT
CAD FILENAME/LAYERS	V10502CU_DC/09A.PRT
<h1>PANDUIT</h1> CORP. TINLEY PARK, ILLINOIS	
POU VERTICAL MOUNTING BRACKET (CVPDUB) CUSTOMER DRAWING	

UNLESS OTHERWISE SPECIFIED, DIMENSIONAL TOLERANCES ARE: INCHES X.X +/- 0.03 X.XX +/- 0.015 X.XXX +/- 0.005 [METRIC - MILLIMETER] X. +/- 0.8 X.X +/- 0.4 X.XX +/- 0.13 ANGLE +/- 1°		UNLESS OTHERWISE SPECIFIED, ALL DIMENSIONS ARE GIVEN IN INCHES, THIRD ANGLE PROJECTION.
DRAWN BY MRWA	MAT'L: SEE NOTES	SCALE NONE
DATE 2-4-11	CHK'D MAY	DRAWING NO. V10502CU-DC SHEET 2 OF 2

REV	DATE	BY	CHK	DESCRIPTION	ECN	R	CUST	SUP	OTH
09A	2-4-11	MRWA	MAY	SEE SHEET 1 OF 2 FOR REVISIONS	V10502CU-DC				