

# Panasonic

NEW

For gas

## Digital Pressure Sensor

DP-0 SERIES

CE  
Conforming to  
EMC Directive

ON

0.0

kPa

Simpler and  
Easier to Use





## Simple & Easy Operation

### Two levels of setting mode for easy operation of essential functions

The "RUN mode" is for threshold value setting, zero point adjustment and key lock setting / release setting, and the "detailed setting mode" allows for basic settings for sensor operation. The two-level setting mode configuration enables easy and immediate use of the product.

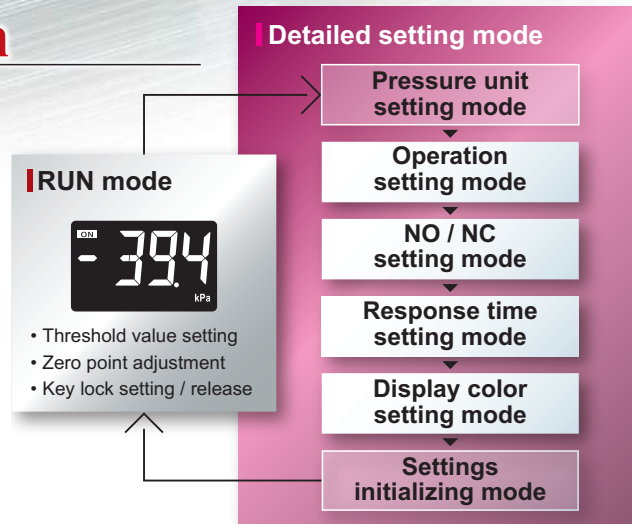

### Main menu for detailed setting mode

Operation setting mode\*

Select from EASY mode, hysteresis mode or window comparator mode.

NO / NC setting mode

Set the comparative output operation to NO or NC.

Response time setting mode

Select the response time from 2.5 ms, 25 ms or 250 ms.

Display color setting mode

Select the comparative output ON / OFF display color and the normal display color from red or white.

\* For details of operation setting mode, see page 4.



## Functional Design

### Black body for enhanced visibility of LCD display

The unit body is completely black to make the LCD display easier to see.

### Firm and crisp clicking feel

The buttons offer firm and crisp clicking feel for smooth and reliable setting operations.

# DP-0

Redesigned for improvement of pressure sensor usability from ground up

Simple

Easy Setting

## High-Quality LCD Display

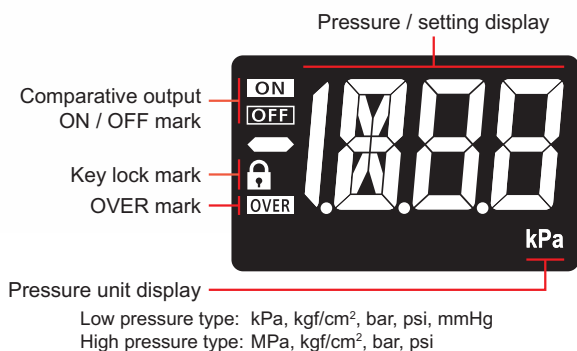

### Simple and highly visible display

The LCD offers a wide viewing angle so the display is easy to see even from an oblique angle. The alphanumeric display (12-segment display), key lock mark and OVER mark further enhance the recognition of display.

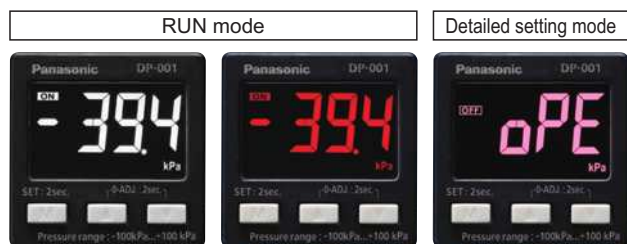

### Selection of display color from red or white

The display color can be selected from red or white in accordance with the output operation. Since the detailed setting mode display is pink (unchangeable), the pressure sensor status can be easily recognized by color.

| Display color setting     | Mode         |                        | Detailed setting mode |
|---------------------------|--------------|------------------------|-----------------------|
|                           | RUN mode     | Comparative output OFF |                       |
| Red for ON, white for OFF | <b>Red</b>   | <b>White</b>           | <b>Pink</b>           |
| White for ON, red for OFF | <b>White</b> | <b>Red</b>             |                       |
| Red in normal status      | <b>Red</b>   |                        |                       |
| White in normal status    | <b>White</b> |                        |                       |

## Compact & Light Weight Design

### Extra-short depth and light weight

The unit body measures only 24.9 mm 0.980 in in depth to allow installation in a narrow space. The main unit weighs only about 25 g. The lightweight unit means minimal load when mounted on a moving part such as a robot arm.

Comparison with previous model (DP-100 series standard pressure port type)

Depth dimension : **Approx. 41% shorter!**

Main unit weight : **Approx. 38% lighter!**

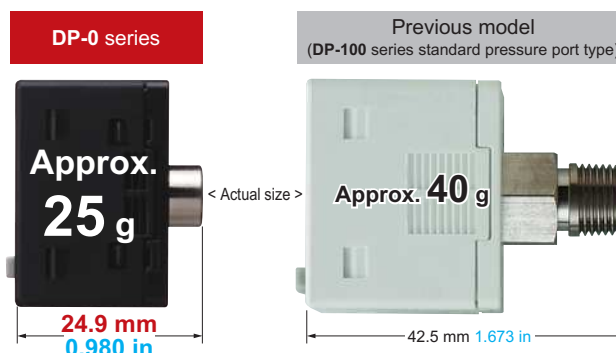

High pressure type



Low pressure type



## Low Pressure Type and High Pressure Type Available

### Two types to choose from according to applications

The low pressure type can be used with positive or negative pressure, while the high pressure type is suitable for positive pressure of up to 1 MPa.

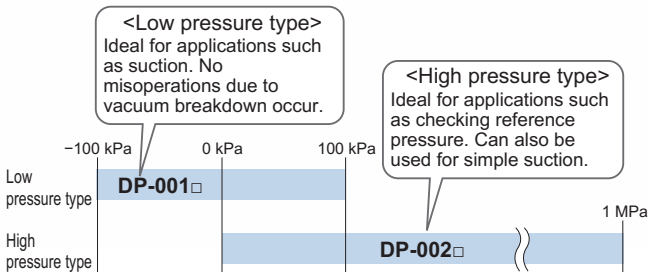

### Applications

Suction confirmation for electronic parts

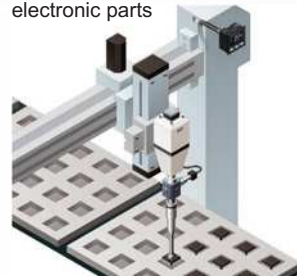

Reference pressure check

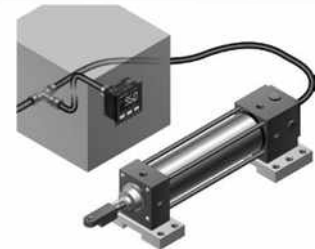

## Three Output Modes

### Equipped with three output modes for use in a wide range of applications

#### (1) EASY mode

This mode is used for comparative output ON / OFF control.

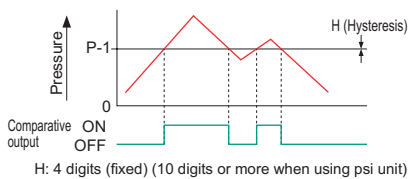

#### (2) Hysteresis mode

This mode is used for setting comparative output hysteresis to the desired level and for carrying out ON / OFF control.

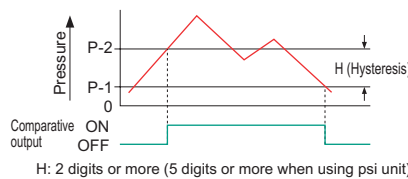

#### (3) Window comparator mode

This mode is used for setting comparative output ON and OFF at pressures within the setting range.

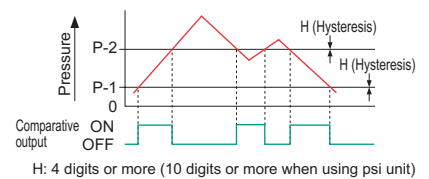

## Designed for Easy Installation

### Panel mounting bracket

### Tight installation is possible

An exclusive mounting bracket that is suitable for 1 to 3 mm **0.039 to 0.118 in** panel thickness is available.

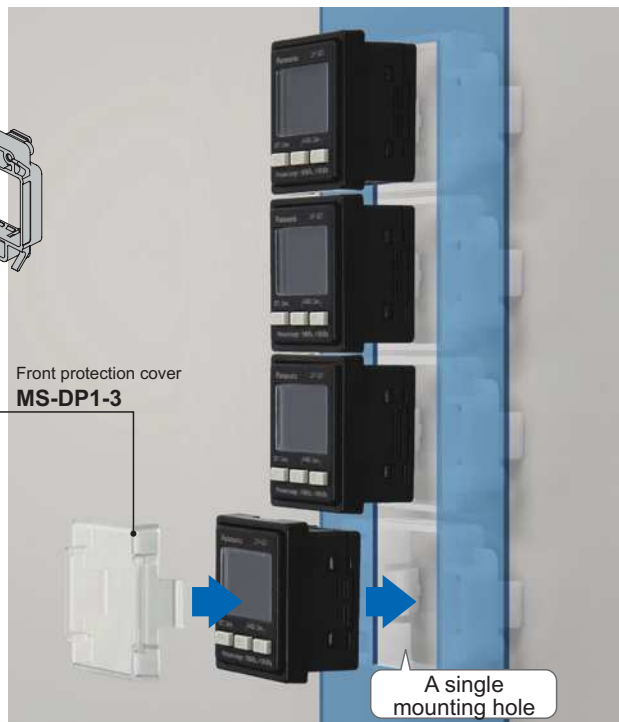
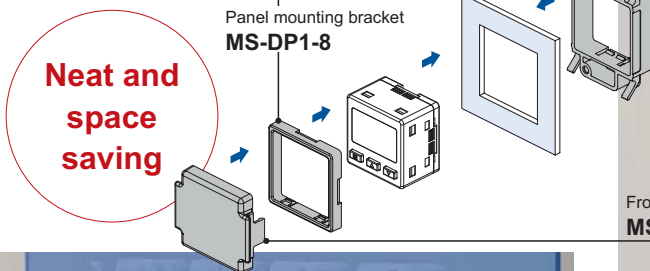

### Exclusive mounting bracket

### Supports tight installation

Space savings can also be achieved even when an L-shaped mounting bracket is used.

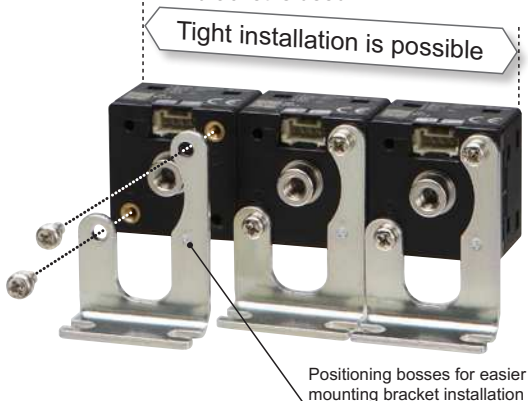

### MS-DP1-1



### MS-DP1-5

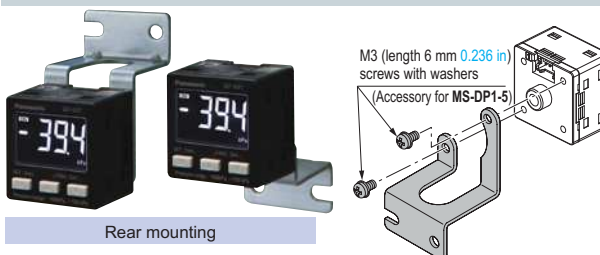

### Connection cable

### Cable can be connected with one-touch

Connector attached cable (2 m **6.562 ft**), as an accessory, can be connected easily with one-touch connection.



### Types without connector attached cable are also available **DP-00□-J**

Commercially-available connectors can be used for cable connections. Cables in required length can be used, so this contributes to reduction in waste of unwanted cables.



\* Options: 1 m **3.281 ft** / 3 m **9.843 ft** / 5 m **16.404 ft** types are also available.

Refer to p.6 for recommended commercially-available connectors.

## ORDER GUIDE

### Model No.

DP-00 **1** - **P** - **J**

Rated pressure range

- 1** : -100.0 to +100.0 kPa (Low pressure type)
- 2** : 0.000 to +1.000 MPa (High pressure type)

Cable

- None : Connector attached cable 2 m [6.562 ft](#)
- J** : Type without connector attached cable

Comparative output

- None : NPN output type
- P** : PNP output type

| Type               | Appearance                                                                                  | Rated pressure range | Model No.       | Pressure port    | Comparative output            |
|--------------------|---------------------------------------------------------------------------------------------|----------------------|-----------------|------------------|-------------------------------|
| Low pressure type  |            | -100.0 to +100.0 kPa | <b>DP-001</b>   | M5 female thread | NPN open-collector transistor |
|                    |                                                                                             |                      | <b>DP-001-P</b> |                  | PNP open-collector transistor |
| High pressure type | * <b>CN-14A-C2</b><br>(Connector attached cable 2 m <a href="#">6.562 ft</a> ) is attached. | 0.000 to +1.000 MPa  | <b>DP-002</b>   |                  | NPN open-collector transistor |
|                    |                                                                                             |                      | <b>DP-002-P</b> |                  | PNP open-collector transistor |

### Type without connector attached cable

Type without connector attached cable **CN-14A-C2** is available. When ordering this type, suffix "-J" to the end of Model No.  
 (e.g.) Type without connector attached cable of **DP-001-P** is "**DP-001-P-J**"

### Accessory

- **CN-14A-C2** (Connector attached cable 2 m [6.562 ft](#))



## OPTIONS

| Designation                               | Model No.               | Description                                                                                                                                 |                                                                                                                                             |
|-------------------------------------------|-------------------------|---------------------------------------------------------------------------------------------------------------------------------------------|---------------------------------------------------------------------------------------------------------------------------------------------|
| Connector attached cable                  | <b>CN-14A-C1</b>        | Length: 1 m <a href="#">3.281 ft</a>                                                                                                        | 0.2 mm <sup>2</sup> 4-core cabtyre cable with connector on one end<br>Cable outer diameter: $\phi$ 3.7 mm <a href="#">0.146 in</a>          |
|                                           | <b>CN-14A-C2</b> (Note) | Length: 2 m <a href="#">6.562 ft</a>                                                                                                        |                                                                                                                                             |
|                                           | <b>CN-14A-C3</b>        | Length: 3 m <a href="#">9.843 ft</a>                                                                                                        |                                                                                                                                             |
|                                           | <b>CN-14A-C5</b>        | Length: 5 m <a href="#">16.404 ft</a>                                                                                                       |                                                                                                                                             |
| Connector attached cable (Flexible cable) | <b>CN-14A-R-C1</b>      | Length: 1 m <a href="#">3.281 ft</a>                                                                                                        | 0.2 mm <sup>2</sup> 4-core flexible cabtyre cable with connector on one end<br>Cable outer diameter: $\phi$ 3.7 mm <a href="#">0.146 in</a> |
|                                           | <b>CN-14A-R-C2</b>      | Length: 2 m <a href="#">6.562 ft</a>                                                                                                        |                                                                                                                                             |
|                                           | <b>CN-14A-R-C3</b>      | Length: 3 m <a href="#">9.843 ft</a>                                                                                                        |                                                                                                                                             |
|                                           | <b>CN-14A-R-C5</b>      | Length: 5 m <a href="#">16.404 ft</a>                                                                                                       |                                                                                                                                             |
| Connector                                 | <b>CN-14A</b>           | Set of 10 housings and 40 contacts                                                                                                          |                                                                                                                                             |
| Sensor mounting bracket                   | <b>MS-DP1-1</b>         | Allows sensors to be installed on the flooring or ceiling. Multiple sensors can also be mounted closely.                                    |                                                                                                                                             |
|                                           | <b>MS-DP1-5</b>         | Allows sensors to be installed on the wall. Multiple sensors can also be mounted closely.                                                   |                                                                                                                                             |
| Panel mounting bracket                    | <b>MS-DP1-8</b>         | Allows installation to panels with thickness of 1 to 3 mm <a href="#">0.039 to 0.118 in</a> . Multiple sensors can also be mounted closely. |                                                                                                                                             |
| Front protection cover                    | <b>MS-DP1-3</b>         | Protects the adjustment surfaces of sensors.<br>(Can be attached when using the panel mounting bracket)                                     |                                                                                                                                             |

### Recommended connector

Contact: SPHD-001T-P0.5,  
 Housing: PAP-04V-S  
 (Manufactured by J.S.T. Mfg. Co., Ltd.)  
 Note: Contact the manufacturer for details of the recommended products.

### Recommended crimping tool

Model No.: YC-610R  
 (Manufactured by J.S.T. Mfg. Co., Ltd.)  
 Note: Contact the manufacturer for details of the recommended products.

Note: The connector attached cable **CN-14A-C2** is supplied with the **DP-0** series.

## SPECIFICATIONS

| Item                                         | Model No.                | Type                                                                                                                                                                                                                                                       | Low pressure    | High pressure                                                                                                                                                                                                                      |                                          |
|----------------------------------------------|--------------------------|------------------------------------------------------------------------------------------------------------------------------------------------------------------------------------------------------------------------------------------------------------|-----------------|------------------------------------------------------------------------------------------------------------------------------------------------------------------------------------------------------------------------------------|------------------------------------------|
|                                              |                          | NPN output                                                                                                                                                                                                                                                 | <b>DP-001</b>   | <b>DP-002</b>                                                                                                                                                                                                                      |                                          |
|                                              |                          | PNP output                                                                                                                                                                                                                                                 | <b>DP-001-P</b> | <b>DP-002-P</b>                                                                                                                                                                                                                    |                                          |
| Type of pressure                             |                          | Gauge pressure                                                                                                                                                                                                                                             |                 |                                                                                                                                                                                                                                    |                                          |
| Rated pressure range                         |                          | -100.0 to +100.0 kPa                                                                                                                                                                                                                                       |                 | 0.000 to +1.000 MPa                                                                                                                                                                                                                |                                          |
| Set pressure range                           |                          | $\left. \begin{array}{l} -101.0 \text{ to } +101.0 \text{ kPa} \\ -1.030 \text{ to } +1.030 \text{ kgf/cm}^2 \\ -1.010 \text{ to } +1.010 \text{ bar} \\ -14.65 \text{ to } +14.65 \text{ psi} \\ -756 \text{ to } +756 \text{ mmHg} \end{array} \right\}$ |                 | $\left. \begin{array}{l} -0.010 \text{ to } +1.010 \text{ MPa} \\ -0.1 \text{ to } +10.30 \text{ kgf/cm}^2 \\ -0.1 \text{ to } +10.10 \text{ bar} \\ -0.1 \text{ to } +146.5 \text{ psi} \end{array} \right\}$                     |                                          |
| Pressure withstandability                    |                          | 500 kPa                                                                                                                                                                                                                                                    |                 | 1.5 MPa                                                                                                                                                                                                                            |                                          |
| Applicable fluid                             |                          | Air, non-corrosive gas                                                                                                                                                                                                                                     |                 |                                                                                                                                                                                                                                    |                                          |
| Selectable unit                              |                          | Low pressure type: kPa, kgf/cm <sup>2</sup> , bar, psi, mmHg High pressure type: MPa, kgf/cm <sup>2</sup> , bar, psi                                                                                                                                       |                 |                                                                                                                                                                                                                                    |                                          |
| Supply voltage                               |                          | 12 to 24 V DC $\pm 10$ % Ripple P-P 10 % or less                                                                                                                                                                                                           |                 |                                                                                                                                                                                                                                    |                                          |
| Power consumption                            |                          | 30 mA or less                                                                                                                                                                                                                                              |                 |                                                                                                                                                                                                                                    |                                          |
| Comparative output                           |                          | <NPN output type><br>NPN open-collector transistor                                                                                                                                                                                                         |                 | <PNP output type><br>PNP open-collector transistor                                                                                                                                                                                 |                                          |
|                                              |                          | <ul style="list-style-type: none"> <li>Maximum sink current: 50 mA</li> <li>Applied voltage: 30 V DC or less<br/>(between comparative output and 0 V)</li> <li>Residual voltage: 2 V or less (at 50 mA sink current)</li> </ul>                            |                 | <ul style="list-style-type: none"> <li>Maximum source current: 50 mA</li> <li>Applied voltage: 30 V DC or less<br/>(between comparative output and +V)</li> <li>Residual voltage: 2 V or less (at 50 mA source current)</li> </ul> |                                          |
|                                              |                          | Output operation                                                                                                                                                                                                                                           |                 | Selectable either NO or NC by key operation                                                                                                                                                                                        |                                          |
|                                              |                          | Hysteresis                                                                                                                                                                                                                                                 |                 | Minimum 2 digits (variable)                                                                                                                                                                                                        |                                          |
|                                              |                          | Repeatability                                                                                                                                                                                                                                              |                 | $\pm 0.2$ % F.S. (within $\pm 4$ digits)                                                                                                                                                                                           | $\pm 0.4$ % F.S. (within $\pm 4$ digits) |
| Response time                                |                          | 2.5 ms, 25 ms, 250 ms, selectable by key operation                                                                                                                                                                                                         |                 |                                                                                                                                                                                                                                    |                                          |
| Short-circuit protection                     |                          | Incorporated                                                                                                                                                                                                                                               |                 |                                                                                                                                                                                                                                    |                                          |
| Display                                      |                          | 3 + 1/2 digits, 3-color (white / red / pink) LCD display (Display update period: 250 ms)                                                                                                                                                                   |                 |                                                                                                                                                                                                                                    |                                          |
| Displayable pressure range                   |                          | $\left. \begin{array}{l} -101.0 \text{ to } +101.0 \text{ kPa} \\ -1.030 \text{ to } +1.030 \text{ kgf/cm}^2 \\ -1.010 \text{ to } +1.010 \text{ bar} \\ -14.65 \text{ to } +14.65 \text{ psi} \\ -756 \text{ to } +756 \text{ mmHg} \end{array} \right\}$ |                 | $\left. \begin{array}{l} -0.010 \text{ to } +1.010 \text{ MPa} \\ -0.1 \text{ to } +10.30 \text{ kgf/cm}^2 \\ -0.1 \text{ to } +10.10 \text{ bar} \\ -0.1 \text{ to } +146.5 \text{ psi} \end{array} \right\}$                     |                                          |
| Environmental resistance                     | Protection               | IP40 (IEC)                                                                                                                                                                                                                                                 |                 |                                                                                                                                                                                                                                    |                                          |
|                                              | Ambient temperature      | 0 to +50 °C <b>+32 to +122 °F</b> (No dew condensation allowed), Storage: -10 to +60 °C <b>+14 to +140 °F</b>                                                                                                                                              |                 |                                                                                                                                                                                                                                    |                                          |
|                                              | Ambient humidity         | 35 to 85 % RH, Storage: 35 to 85 % RH                                                                                                                                                                                                                      |                 |                                                                                                                                                                                                                                    |                                          |
|                                              | Voltage withstandability | 500 V AC for one min. between all supply terminals connected together and enclosure                                                                                                                                                                        |                 |                                                                                                                                                                                                                                    |                                          |
|                                              | Insulation resistance    | 50 M $\Omega$ or more with 500 V DC megger between all supply terminals connected together and enclosure                                                                                                                                                   |                 |                                                                                                                                                                                                                                    |                                          |
|                                              | Vibration resistance     | 10 to 150 Hz frequency, amplitude 0.75 mm <b>0.030 in</b> or maximum acceleration 49 m/s <sup>2</sup> , in X, Y and Z directions for two hours each                                                                                                        |                 |                                                                                                                                                                                                                                    |                                          |
|                                              | Shock resistance         | 100 m/s <sup>2</sup> acceleration (10 G approx.) in X, Y and Z directions for three times each                                                                                                                                                             |                 |                                                                                                                                                                                                                                    |                                          |
| Pollution degree                             |                          | 2                                                                                                                                                                                                                                                          |                 |                                                                                                                                                                                                                                    |                                          |
| Overvoltage category                         |                          | I                                                                                                                                                                                                                                                          |                 |                                                                                                                                                                                                                                    |                                          |
| Usable altitude                              |                          | 2,000 m <b>6,562 ft</b> or less                                                                                                                                                                                                                            |                 |                                                                                                                                                                                                                                    |                                          |
| Temperature characteristics (+20°C standard) |                          | +10 to +40°C <b>+50 to +104°F</b> : Within $\pm 1$ % F.S.<br>0 to +50°C <b>32 to +122°F</b> : Within $\pm 2.5$ % F.S.                                                                                                                                      |                 | +10 to +40°C <b>+50 to +104°F</b> : Within $\pm 2$ % F.S.<br>0 to +50°C <b>32 to +122°F</b> : Within $\pm 5$ % F.S.                                                                                                                |                                          |
| Grounding method                             |                          | Floating                                                                                                                                                                                                                                                   |                 |                                                                                                                                                                                                                                    |                                          |
| Pressure port                                |                          | M5 female thread                                                                                                                                                                                                                                           |                 |                                                                                                                                                                                                                                    |                                          |
| Material                                     |                          | Enclosure: PBT (glass fiber reinforced), LCD display: Acrylic, Pressure port: Brass (nickel plated), Mounting threaded part: Brass, O-ring: Nitrile rubber (NBR), Key section: Polycarbonate                                                               |                 |                                                                                                                                                                                                                                    |                                          |
| Weight                                       |                          | 25 g approx.                                                                                                                                                                                                                                               |                 |                                                                                                                                                                                                                                    |                                          |
| Accessory                                    |                          | <b>CN-14A-C2</b> (Connector attached cable 2 m <b>6.562 ft</b> ): 1 pc.                                                                                                                                                                                    |                 |                                                                                                                                                                                                                                    |                                          |

Note: Where measurement conditions have not been specified precisely, the conditions used were an ambient temperature of +20 °C **+68 °F**.

## I/O CIRCUIT AND WIRING DIAGRAMS

### NPN output type

#### I/O circuit diagram

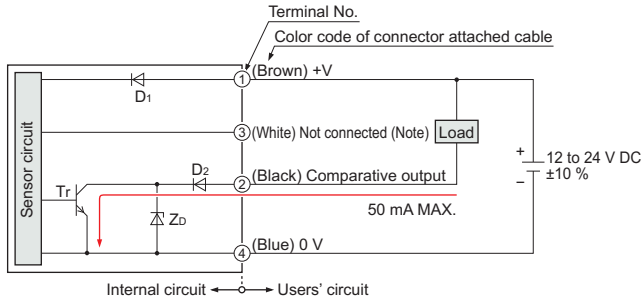

Note: Open or, connect to 0 V.

Symbols...D1, D2: Reverse supply polarity protection diode  
 ZD: Surge absorption zener diode  
 Tr: NPN output transistor

#### Terminal arrangement diagram

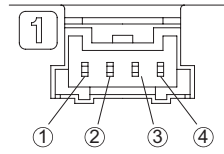

| Terminal No. | Designation          |
|--------------|----------------------|
| ①            | +V                   |
| ②            | Comparative output   |
| ③            | Not connected (Note) |
| ④            | 0V                   |

Note: Open or, connect to 0 V.

### PNP output type

#### I/O circuit diagram

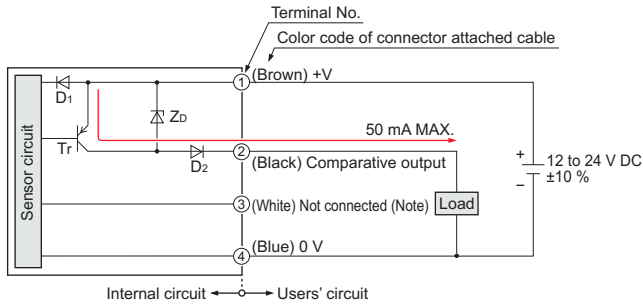

Note: Open or, connect to 0 V.

Symbols...D1, D2: Reverse supply polarity protection diode  
 ZD: Surge absorption zener diode  
 Tr: PNP output transistor

#### Terminal arrangement diagram

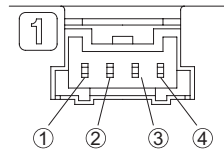

| Terminal No. | Designation          |
|--------------|----------------------|
| ①            | +V                   |
| ②            | Comparative output   |
| ③            | Not connected (Note) |
| ④            | 0V                   |

Note: Open or, connect to 0 V.



## PRECAUTIONS FOR PROPER USE



- Never use this product as a sensing device for personnel protection.
- In case of using sensing devices for personnel protection, use products which meet laws and standards, such as OSHA, ANSI or IEC etc., for personnel protection applicable in each region or country.
- This product is used for noncorrosive gas. The product shall not be used for liquid or corrosive gas. Never use fluids having inflammability, toxicity, etc., that affect the human body, either.

### Part description

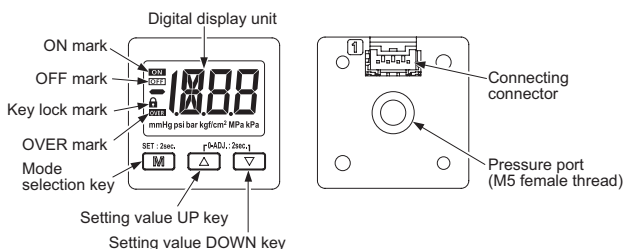

### Piping

- When using this product, connect a joint available in the market to the pressure port. At the time, the tightening torque should be 1.0 N·m or less.

### Mounting

- Use sensor mounting bracket **MS-DP1-1** prepared independently. When mounting this product with sensor mounting bracket, etc., the tightening torque should be 0.5 N·m or less.

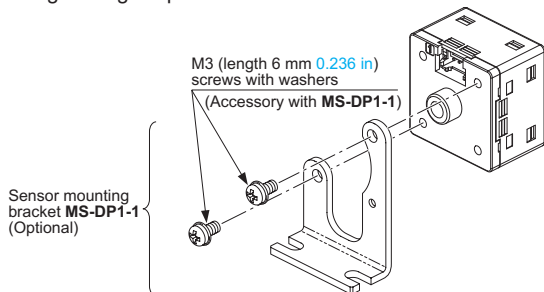

- Panel fittings **MS-DP1-8** (optional) and front cover **MS-DP1-3** (optional) are available.
- For the method for mounting panel fittings, refer to the instruction manual that came with the **MS-DP1-8**.

### Wiring

- Make sure that the power supply is OFF while performing the wiring operation.
- Verify that the supply voltage variation is within the rating.
- If power is supplied from a commercial switching regulator, ensure that the frame ground (F.G.) terminal of the power supply is connected to an actual ground.
- In case noise generating equipment (switching regulator, inverter motor, etc.) is used in the vicinity of this product, connect the frame ground (F.G.) terminal of the equipment to an actual ground.
- When extending the cable, use a cable whose conductor cross-sectional area is 0.3 mm<sup>2</sup> or more. The cable can be extended to up to 10 m **32.808 ft** in total length.
- Do not run the wires together with high-voltage lines or power lines or put them in the same raceway. This can cause malfunction due to induction.
- Do not apply stress directly to the connection cable leader or to the connector.

### Connection

#### How to connect

- Insert the cable with connector **CN-14A(-R)-C□** into this product's connection connector section as shown in the right figure.

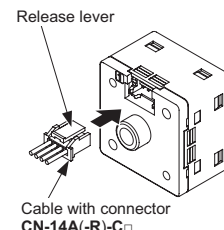

#### How to disconnect

- Pressing the release lever of the cable with connector, pull out the connector.

Note: Do not pull by holding the cable without pressing the release lever, as this can cause cable break or connector break.

### Factory setting

| Type              | Low pressure type           | High pressure type |
|-------------------|-----------------------------|--------------------|
| Operation setting | EASY mode                   |                    |
| NO / NC setting   | NC                          | NO                 |
| Threshold value   | -50.0                       | 0.500              |
| Pressure unit     | kPa                         | MPa                |
| Display color     | Red when ON, White when OFF |                    |
| Response speed    | 2.5 ms                      |                    |

### Error indication

| Error indication | Description                                                                                   | Remedy                                                                                                                          |
|------------------|-----------------------------------------------------------------------------------------------|---------------------------------------------------------------------------------------------------------------------------------|
|                  | The load is short-circuited causing an overcurrent to flow.                                   | Turn OFF the power and check the load.                                                                                          |
|                  | Pressure is applied during zero point adjustment.                                             | Applied pressure at the pressure port should be brought to atmospheric pressure and zero-point adjustment should be done again. |
|                  | The applied pressure exceeds the upper limit of the displayed pressure range.                 | Applied pressure range should be brought within the rated pressure range.                                                       |
|                  | The applied pressure exceeds the lower limit (back pressure) of the displayed pressure range. |                                                                                                                                 |

When other error message is displayed, contact us.

### Others

- This product has been developed / produced for industrial use only.
- The product shall be used only within the rated pressure range.
- Do not apply pressure exceeding the pressure resistance. Otherwise, destruction of diaphragm occurs, preventing the product to perform normal operation.
- Do not use during the initial transient time (0.5 sec.) after the power supply is switched ON.
- The specification may not be satisfied in a strong magnetic field.
- This product is suitable for indoor use only.
- Take care that strong impact such as fall is not given to this product. Otherwise, it may be destroyed.
- Avoid dust, dirt, and steam.
- Take care that the product does not come into contact with organic solvents such as thinner.
- Take care that the product does not come into contact with oil or grease.
- Take care that the product does not come into contact with strong acid or alkaline.
- Do not insert wire into the pressure port. Otherwise, destruction of diaphragm occurs, preventing the product to perform normal operation.

### DP-00

### Sensor

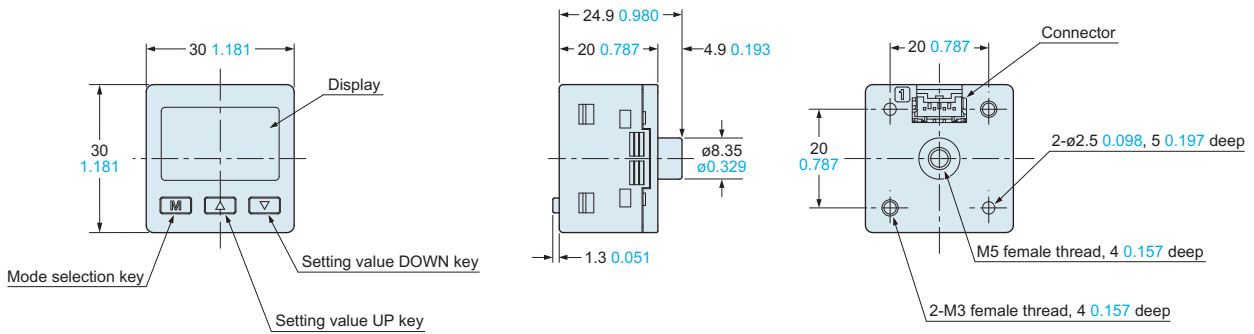

### MS-DP1-1

### Sensor mounting bracket (Optional)

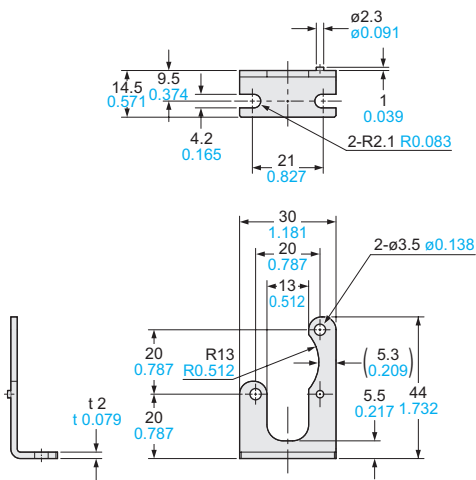

### Assembly dimensions

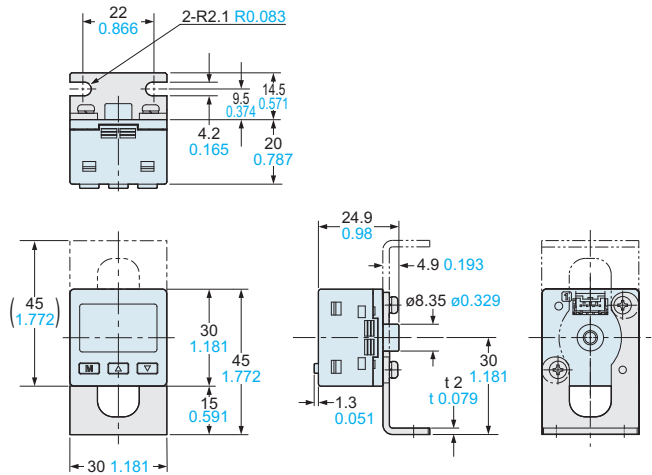

Material: Cold rolled carbon steel (SPCC)  
(Uni-chrome plated)  
Two M3 (length 6 mm 0.236 in) screws with washers are attached.

### MS-DP1-5

### Sensor mounting bracket (Optional)

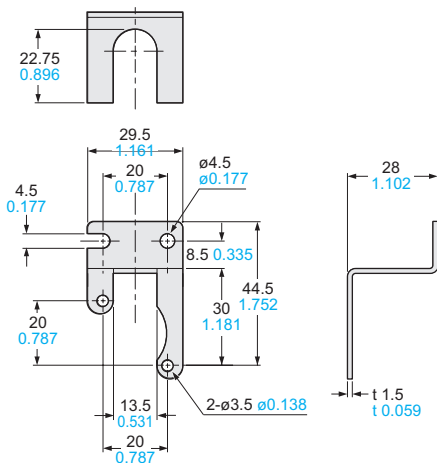

### Assembly dimensions

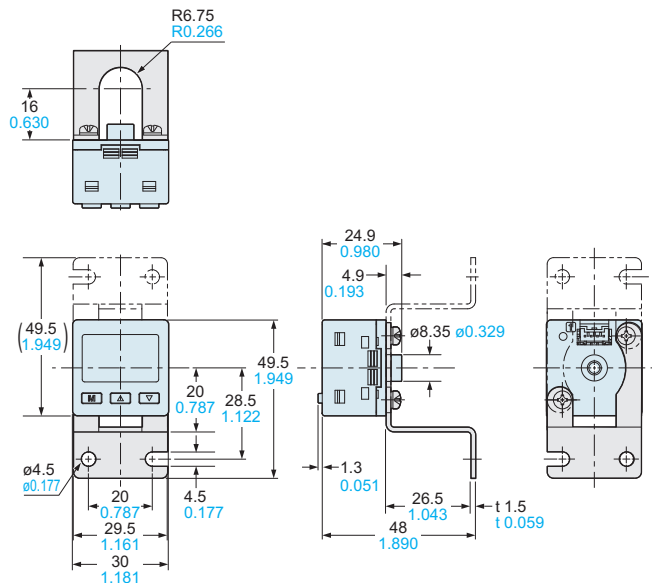

Material: Stainless steel (SUS304)  
Two M3 (length 6 mm 0.236 in) screws with washers are attached.

**DIMENSIONS (Unit: mm in)**

The CAD data can be downloaded from the website.

MS-DP1-8 MS-DP1-3

Panel mounting bracket (Optional), Front protection cover (Optional)

**Mounting drawing with DP-00**

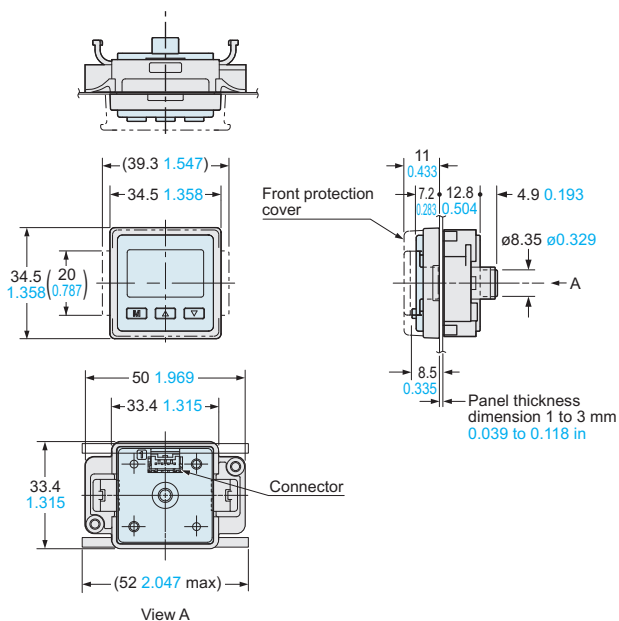

**Panel cut-out dimensions**

When 1 unit is installed

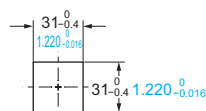

When "n" units are installed horizontally in series

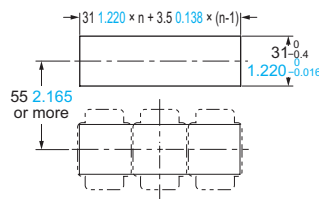

When "n" units are installed vertically in series

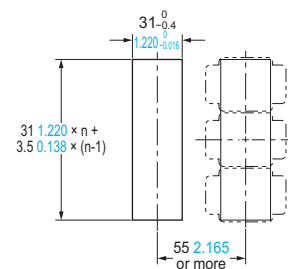

Note: The panel thickness should be 1 to 3 mm 0.039 to 0.118 in.

Note: The panel thickness should be 1 to 3 mm 0.039 to 0.118 in.

CN-14A(-R)-C

Connector attached cable (Optional, CN-14A-C2 is attached to the sensor)

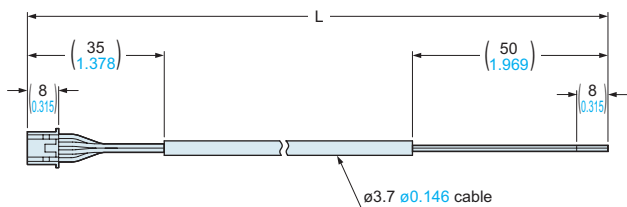

| Model No.     | Cable length L (mm in) |
|---------------|------------------------|
| CN-14A(-R)-C1 | 1,000 39.370           |
| CN-14A(-R)-C2 | 2,000 78.740           |
| CN-14A(-R)-C3 | 3,000 118.110          |
| CN-14A(-R)-C5 | 5,000 196.850          |

# Pressure Sensor Lineup

## Higher precision, more advanced function

Dual Display Digital Pressure Sensor For gas

### DP-100 SERIES Ver.2



- Dual-screen 3-color display (red, green, orange) for added ease of operation.
- Wide variation of pressure ports.
- Provided with 2 outputs (standard type).
- Provided with analog output or external input (multi-function type).
- Provided with copy function for reduced man-hours and human error.
- Oil-free type also available for prevention of entry of oil or grease in air pipes.
- Compound pressure types (for low pressure / for high pressure) are available.

## Detection of liquid pressure

Head-separated Dual display Digital Pressure Sensor For gas & liquid

### DPC-L100 SERIES DPH-L100 SERIES



- High-precision liquid / air pressure detection and excellent operability.
- Compact stainless steel body withstands pressure of up to 50 MPa.
- Oil-less, single diaphragm structure.
- Mounted with throttle to achieve high resistance to pressure surge.
- Standalone use of sensor head is possible.
- Provided with 2 outputs (analog voltage and current).
- Compound pressure type and positive pressure type are available.

## Installation on a panel or moving part possible

Head-separated Dual Display Digital Pressure Sensor For gas

### DPC-100 SERIES DPH-100 SERIES



- High response speed of 500  $\mu$ s.
- Automatic recognition of sensor head without initial setting.
- Sensor head can be installed easily using an Allen wrench.
- Standalone use of sensor head is possible.
- Provided with 2 outputs (analog voltage and current).
- Compound pressure type, positive pressure type and negative pressure type are available.

## Multi-unit connection and network communication supported

Head-separated Dual Display Digital Pressure Sensor For gas

### DPS-400 SERIES DPH-100 SERIES



- Ultra-high response speed of 150  $\mu$ s.
- Network communication is possible.
- Allows connection of up to 16 units and copying of settings.
- One-touch cable for reduced wiring work.
- Sensor head can be installed easily using an Allen wrench.
- Standalone use of sensor head is possible.
- Provided with 2 outputs
- Compound pressure type, positive pressure type and negative pressure type are available.

## Disclaimer

The applications described in the catalog are all intended for examples only. The purchase of our products described in the catalog shall not be regarded as granting of a license to use our products in the described applications. We do NOT warrant that we have obtained some intellectual properties, such as patent rights, with respect to such applications, or that the described applications may not infringe any intellectual property rights, such as patent rights, of a third party.

Please contact:

## Panasonic Industrial Devices SUNX Co., Ltd.

2431-1 Ushiyama-cho, Kasugai-shi, Aichi, 486-0901, Japan

Global Sales Department

■Telephone: +81-568-33-7861 ■Facsimile: +81-568-33-8591

panasonic.net/id/pidsx/global

All Rights Reserved ©Panasonic Industrial Devices SUNX Co., Ltd. 2015