

A B C D E F G H

REV	DESCRIPTION	DATE
-----	-------------	------

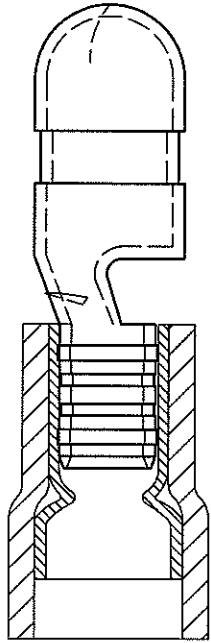
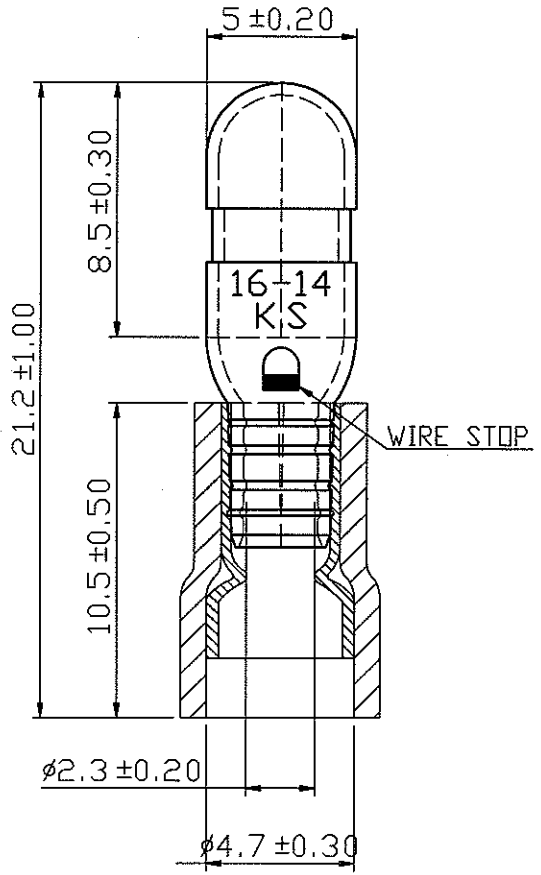
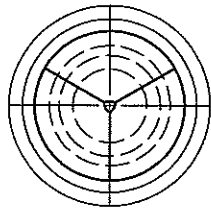

- NOTE :
1. MAXIMUM ELECTRIC CURRENT :

A.W.G.	16	14	
AMP.	10	15	
 2. MAXIMUM ELECTRICAL RATING : 75°C 600 VOLTS MAX.
 3. INSULATION MATERIAL : VINYL
 4. INSULATION COLOR : BLUE
 5. TERMINAL MATERIAL : BRASS
 6. WIRE RANGE : 16-14 A.W.G. (1.5-2.5 mm²)
 7. DOUBLE CRIMP : WITH COPPER SLEEVE ON BARREL
 8. TERMINAL SURFACE TREATMENT : TIN PLATED
 9. TERMINAL THICKNESS : 0.40 mm

Tolerance Unless Otherwise Specified	
0 > 6 mm ± 0.20	ANGLE
6 > 18 mm ± 0.30	0° REF ±
18 > 30 mm ± 0.40	° ±
30 > 75 mm ± 0.50	° ±

NAME	VINYL-INSULATED DOUBLE CRIMP BULLET DISCONNECTORS			UNIT	①
PART NO.	MPD2-195	MATERIAL	-----	APPROVE	<i>[Signature]</i>
NUMBER	KA-95156-C	SCALE	SHEET PAGE	CHECKED	<i>[Signature]</i>
DATE	2006/03/27	4/1	1-0 10F2	DRAWN	張馨尹

KST. K.S. TERMINALS INC.

A B C D E F G H