



# MPQ4480

## 6A, 36V, Step-Down Converter for Automotive, AEC-Q100 Qualified

### DESCRIPTION

The MPQ4480 is a high-frequency, synchronous rectified, step-down, switch-mode converter. It achieves 6A output current over a wide input-supply range with excellent load and line regulation over a wide input supply range. The MPQ4480 has synchronous mode operation for higher efficiency over the output load range.

Fault condition protection includes hiccup current limiting, OVP, and thermal shutdown (TSD).

The MPQ4480 requires a minimal number of readily available, standard external components. The MPQ4480 is available in a QFN-25 (4mmx5mm) package.

### FEATURES

- 4.2V to 36V Operating Input Voltage Range
- 6A Output Current
- Internal Auto EN Pull-Up
- 20mΩ/15mΩ Low  $R_{DS(ON)}$  Internal Buck Power MOSFETs
- Integrated 4mΩ Ground Sensing Resistor
- Frequency Adjustable (235kHz to 2.2MHz)
- CC Output Current Limit, 3-Level Adjustable, 2.75A/3.75A/7.5A
- Forced PWM Mode
- Frequency SYNC from 300kHz to 2.1MHz (Recommend: <25% of SYNC Duty Cycle)
- Spread Spectrum Option with 450kHz  $f_{SW}$
- EN Shutdown Discharge
- Low Dropout Mode
- Battery Short to Ground Protect Driver
- Output Over-Voltage Protection
- Adjustable Line Drop Compensation
- Support 1V to 20V Output Adjustable
- Available in a QFN-25 (4mmx5mm) Package with Wettable Flanks
- Available in AEC-Q100 Grade 1

### APPLICATIONS

- Automotive Infotainment System
- Automotive USB Hub
- Wireless Charging

All MPS parts are lead-free, halogen free, and adhere to the RoHS directive. For MPS green status, please visit MPS website under Quality Assurance. "MPS", the MPS logo, and "Simple, Easy Solutions" are registered trademarks of Monolithic Power Systems, Inc. or its subsidiaries.

### TYPICAL APPLICATION

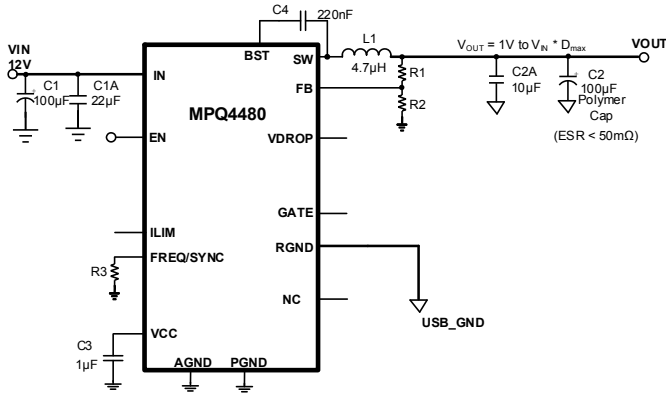

### Efficiency vs. Output Current

$V_{OUT} = 5V$ ,  $f_{sw} = 440kHz$ ,  $L = 4.7\mu H$ ,  
 $DCR = 7m\Omega$

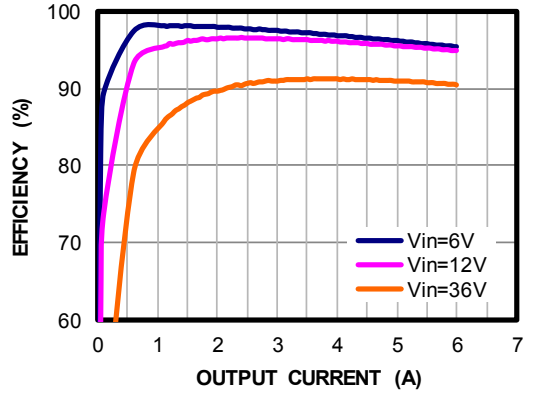

### ORDERING INFORMATION

Part Number*	Package	Top Marking
MPQ4480GV-AEC1*	QFN-25 (4mmx5mm)	See Below
MPQ4480GV-FD-AEC1**	QFN-25 (4mmx5mm)	See Below

\* For Tape & Reel, add suffix -Z (e.g. MPQ4480GV-AEC1-Z)

\*\* For Tape & Reel, add suffix -Z (e.g. MPQ4480GV-FD-AEC1-Z)

### DEVICE COMPARISON INFORMATION

Part Number	Frequency Spread Spectrum
MPQ4480GV-AEC1	No
MPQ4480GV-FD-AEC1	Yes

### TOP MARKING

**MPSYWW**

**MP4480**

**LLLLLL**

MPS: MPS prefix  
 Y: Year code  
 WW: Week code  
 MP4480: Part number  
 LLLLLL: Lot number

### PACKAGE REFERENCE

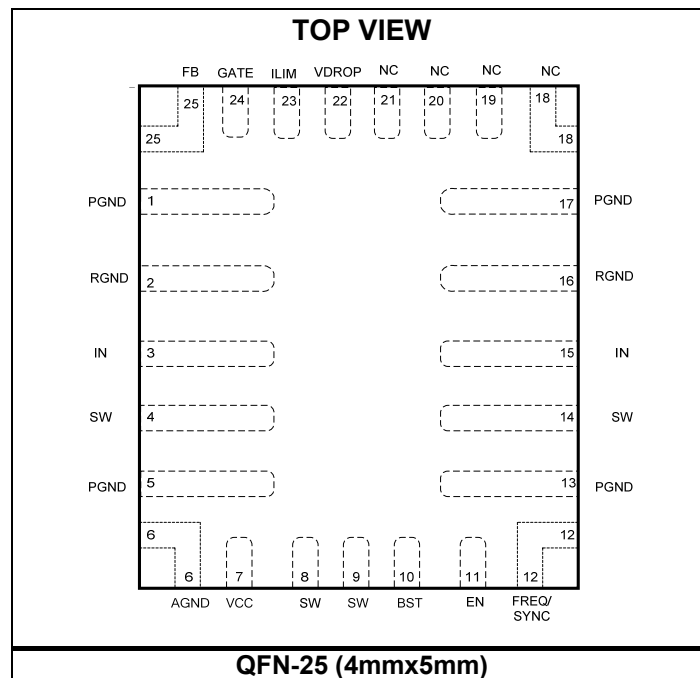

## PIN FUNCTIONS

Pin #	Name	Description
1, 5, 13, 17	PGND	<b>Power ground.</b> Reference ground of the regulated output voltage. PGND requires extra care during PCB layout. Connect to GND with copper traces and vias. All PGND pins must be connected together.
2, 16	RGND	<b>Remote power ground.</b> There is an internal 4mΩ current-sensing resistor from RGND to PGND (pin 17 and pin 1).
3, 15	IN	<b>Supply voltage.</b> The MPQ4480 operates from a 4.2V to 36V input voltage. C <sub>IN</sub> prevents large voltage spikes at the input. Place C <sub>IN</sub> as close to the IC as possible. IN is the drain of the internal power device, and provides the power supply for the entire chip.
4, 8, 9, 14	SW	<b>Switch output.</b> These pins must be connected together by a PCB trace. Use a wide PCB trace to make the connection.
6	AGND	<b>Analog ground.</b> Connect AGND to PGND.
7	VCC	<b>Internal 5.05V LDO regulator output.</b> Decouple with a 1μF capacitor.
10	BST	<b>Bootstrap.</b> A 0.22μF capacitor is connected between SW and BST to form a floating supply across the high-side switch driver.
11	EN	<b>On/off control input.</b> The enable pin is an internal auto pull-up with a 7μA current source. EN has two stage thresholds: when EN is higher than ~1V, the VCC and bias circuitry will be enabled; when EN is higher than 2V, the buck switcher starts to work.
12	FREQ/SYNC	<b>Switching frequency program input.</b> Connect a resistor from FREQ to GND to set the switching frequency. This pin also serves as a frequency-synchronous clock input.
18, 19, 20, 21	NC	<b>No connection.</b> These pins should be left floating.
22	VDROP	<b>Line drop amplitude selection.</b> Three levels can be programmable by pulling VDROP to GND or VCC, or floating.
23	ILIM	<b>Output CC current limit set pin.</b> Pull ILIM to VCC, GND, or float to set three different current limit levels.
24	GATE	<b>Gate drive for external, low-side, N-channel power MOSFET.</b> Open-drain structure. The GATE pin is pulled low to turn off the power MOSFET when the secondary current RGND-to-PGND limit is triggered.
25	FB	<b>Feedback.</b> Connect to the tap of an external resistor divider from the output to GND to set the output voltage.

**ABSOLUTE MAXIMUM RATINGS** <sup>(1)</sup>

Supply voltage ( $V_{IN}$ )	40V
$V_{SW}$	
-0.3V (-5V for <10ns) to $V_{IN} + 0.3V$ (43V for <10ns)	
$V_{BST}$	$V_{SW} + 5.5V$
$V_{EN}$	-0.3V to +10V <sup>(2)</sup>
All other pins	-0.3V to +5.5V
Continuous power dissipation ( $T_A = 25^\circ C$ ) <sup>(3) (5)</sup>	
QFN-25 (4mmx5mm)	5.4W
Junction temperature	150°C
Lead temperature	260°C
Storage temperature	-65°C to +150°C

**Recommended Operating Conditions** <sup>(4)</sup>

Operation input voltage range	4.2V to 36V
Output current	6A
Output voltage range	1V to $V_{IN} * D_{MAX}$
Operating junction temp	-40°C to +125°C

<b>Thermal Resistance</b>	$\theta_{JA}$	$\theta_{JC}$
QFN-25 (4mmx5mm)		
EVQ4480-V-00A <sup>(5)</sup>	23	4 °C/W
JESD51-7 <sup>(6)</sup>	44	9 °C/W

**Notes:**

- 1) Exceeding these ratings may damage the device.
- 2) About the details of EN pin's ABS Max rating, see the EN control section on page 14.
- 3) The maximum allowable power dissipation is a function of the maximum junction temperature  $T_J (MAX)$ , the junction-to-ambient thermal resistance  $\theta_{JA}$ , and the ambient temperature  $T_A$ . The maximum allowable continuous power dissipation at any ambient temperature is calculated by  $P_D (MAX) = (T_J (MAX) - T_A) / \theta_{JA}$ . Exceeding the maximum allowable power dissipation will cause excessive die temperature, and the regulator will go into thermal shutdown. Internal thermal shutdown circuitry protects the device from permanent damage.
- 4) The device is not guaranteed to function outside of its operating conditions.
- 5) Measured on EVQ4480-V-00A, 4-layer PCB, 50mmx50mm.
- 6) Measured on JESD51-7, 4-layer PCB. The value of  $\theta_{JA}$  given in this table is only valid for comparison with other packages and cannot be used for design purposes. These values were calculated in accordance with JESD51-7 and simulated on a specified JEDEC board. They do not represent the performance obtained in an actual application.

## ELECTRICAL CHARACTERISTICS

$V_{IN} = 12V$ ,  $V_{EN} = 5V$ ,  $T_J = -40^{\circ}C$  to  $+125^{\circ}C$ , typical value is tested at  $T_J = 25^{\circ}C$ , unless otherwise noted.

Parameter	Symbol	Condition	Min	Typ	Max	Units
Supply current (shutdown)	$I_{IN}$	$V_{EN} = 0V$ , $T_J = -40^{\circ}C$ to $+125^{\circ}C$		15	25	$\mu A$
Supply current (quiescent)	$I_{Q2}$	No switching		1	2	mA
EN rising threshold	$V_{EN\_Rising}$		1.96	2.06	2.16	V
EN hysteresis	$V_{EN\_HYS}$			200		mV
EN pull-up current	$I_{EN}$	$V_{EN} = 3V$	3	7	11	$\mu A$
Thermal shutdown <sup>(7)</sup>	$T_{STD}$			165		$^{\circ}C$
Thermal hysteresis <sup>(7)</sup>	$T_{STD\_HYS}$			20		$^{\circ}C$
VCC regulator	$V_{CC}$		4.65	5.05	5.45	V
VCC load regulation	$V_{CC\_LOG}$	$I_{CC} = 50mA$		1	3	%
<b>Step-Down Converter</b>						
$V_{IN}$ under-voltage lockout threshold rising	$V_{IN\_UVLO}$		3.7	3.95	4.2	V
$V_{IN}$ under-voltage lockout threshold hysteresis	$V_{UVLO\_HYS}$			500		mV
HS switch on resistance	$R_{DSON\_HS}$			20	40	m $\Omega$
LS switch on resistance	$R_{DSON\_LS}$			15	35	m $\Omega$
Feedback voltage	$V_{FB}$		0.985	1	1.015	V
Low-side current limit <sup>(7)</sup>	$I_{LS\_LIMIT}$			-2		A
Switch leakage	$SW_{LKG}$	$V_{EN} = 0V$ , $V_{SW} = 36V$ , $T_J = 25^{\circ}C$			1	$\mu A$
		$V_{EN} = 0V$ , $V_{SW} = 36V$ , $T_J = -40^{\circ}C$ to $+125^{\circ}C$			5	
High-side current limit	$I_{LIMIT1}$	$I_{LIM} = GND$	8	17	27	A
		$I_{LIM} = V_{CC}$	12	22	35	
Output CC current limit	$I_{LIMIT2}$	$I_{LIM} = V_{CC}$ (for 6A continuous), $T_J = 25^{\circ}C$	6.6	7.5	8.4	A
		$I_{LIM} = float$ (for 3A continuous), $T_J = 25^{\circ}C$	3.3	3.75	4.2	
		$I_{LIM} = GND$ (for 2.4A continuous), $T_J = 25^{\circ}C$	2.5	2.75	3	
Oscillator frequency	$f_{SW1}$	$R_{FREQ} = 97.6k\Omega$	170	235	300	kHz
	$f_{SW2}$	$R_{FREQ} = 9.53k\Omega$	1800	2200	2600	
	$f_{SW3}$	$R_{FREQ} = 52.3k\Omega$	350	440	530	
Frequency spread spectrum <sup>(7)</sup> (MPQ4480GV-FD-AEC1)	$f_{SS}$	$R_{FREQ} = float$ , based on 450kHz		10		%
Sync frequency range	$FREQ_{SYNC\_IN}$		300		2100	kHz
Maximum on time	$t_{ON\_MAX}$	Dropout mode, max duty cycle $D_{MAX} = t_{ON\_MAX} / (t_{ON\_MAX} + t_{OFF\_MIN})$	6	10		$\mu s$
Minimum off time	$t_{OFF\_MIN}$			120		ns
Minimum on time <sup>(7)</sup>	$t_{ON\_MIN}$			130		ns

**ELECTRICAL CHARACTERISTICS (continued)**

$V_{IN} = 12V$ ,  $V_{EN} = 5V$ ,  $T_J = -40^{\circ}C$  to  $+125^{\circ}C$ , typical value is tested at  $T_J = 25^{\circ}C$ , unless otherwise noted.

Soft-start time	$t_{SS}$	10% to 90% $V_{OUT}$	0.4	1.1	1.8	ms
Line drop compensation gain (from $I_{RTN}$ to $I_{FB}$ )	Gain1	VDROP pin = GND, $T_J = 25^{\circ}C$	0.1	0.6	1.1	$\mu A/A$
	Gain2	VDROP pin = float, $T_J = 25^{\circ}C$	1.5	3.25	5	$\mu A/A$
	Gain3	VDROP pin = VCC, $T_J = 25^{\circ}C$	4	6.75	9.5	$\mu A/A$
<b>OVP</b>						
OVP rising threshold	$V_{OVP1\_RISE}$		110%	115%	120%	$V_{REF}$
OVP falling threshold	$V_{OVP\_FALL}$			105%		$V_{REF}$
OVP delay <sup>(7)</sup>	$t_{OVPDEL}$			2		$\mu s$
<b>RGND Current Limit</b>						
RGND to PGND resistor	$R_{SENSE}$			4	12	m $\Omega$
Second current limit threshold	$V_{SENSE\_TH}$			12		A
GATE pull-low resistance	$R_{GATE\_L}$			85	180	$\Omega$
Second current limit off time	$t_{EXT\_CUR\_RES}$		1	2	3	s

**Note:**

7) Guaranteed by engineering sample characterization.

## TYPICAL PERFORMANCE CHARACTERISTICS

$V_{IN} = 12V$ ,  $V_{OUT} = 5V$ ,  $L = 4.7\mu H$ ,  $f_{SW} = 440kHz$ ,  $T_A = 25^\circ C$ , unless otherwise noted.

**Efficiency vs. Output Current**

$V_{OUT} = 5V$ ,  $f_{SW} = 440kHz$ ,  $L = 4.7\mu H$

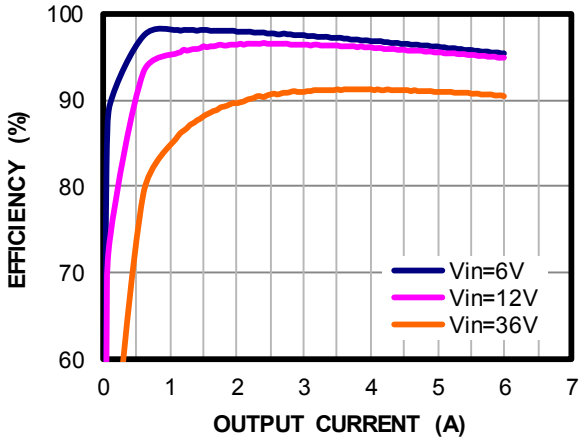

**Efficiency vs. Output Current**

$V_{OUT} = 5V$ ,  $f_{sw} = 2.2MHz$ ,  $L = 2.2\mu H$

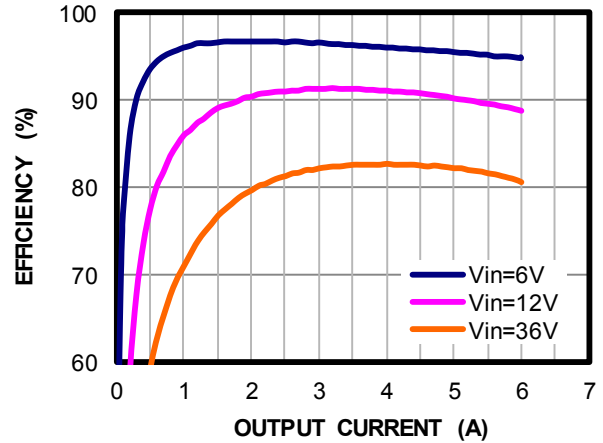

**Line Drop Compensation**

$R1 = 40.2k\Omega$

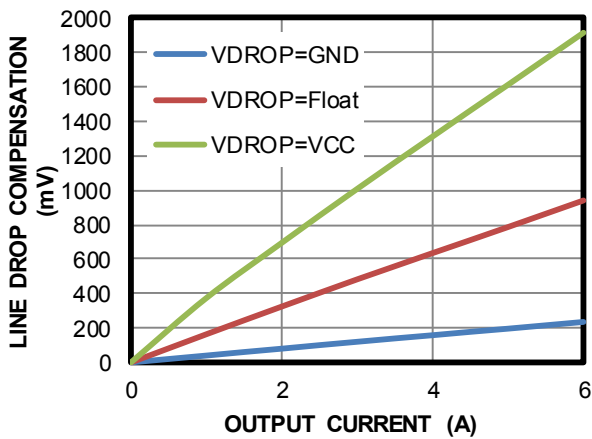

**Case Temperature Rise vs. IOU**

4-layers, 5cmx5cm

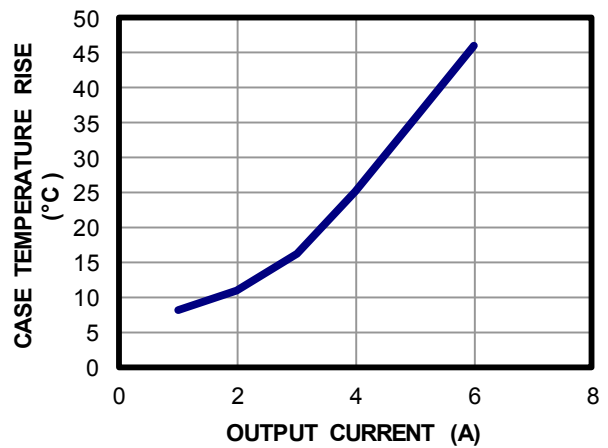



### TYPICAL PERFORMANCE CHARACTERISTICS *(continued)*

$V_{IN} = 12V$ ,  $V_{OUT} = 5V$ ,  $L = 4.7\mu H$ ,  $f_{SW} = 440kHz$ ,  $T_A = 25^\circ C$ , unless otherwise noted. All waveforms are tested based on bypassing the external MOSFET except Short Battery to Ground.

#### Output Ripple

$f_{SW} = 440kHz$ ,  $L = 4.7\mu H$ ,  $I_{OUT} = 0A$

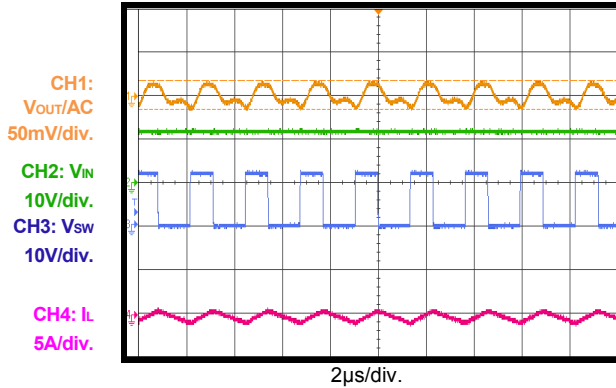

#### Output Ripple

$f_{SW} = 440kHz$ ,  $L = 4.7\mu H$ ,  $I_{OUT} = 6A$

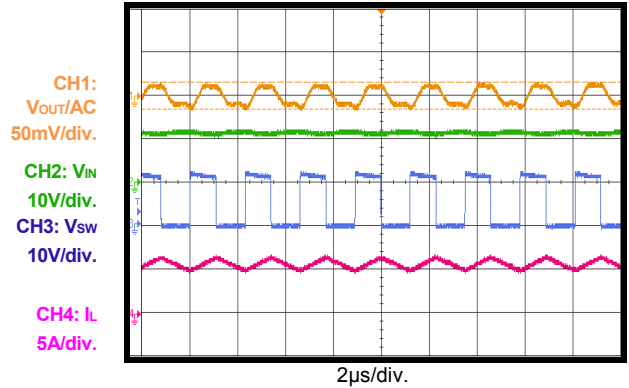

#### Output Ripple

$f_{SW} = 2.2MHz$ ,  $L = 2.2\mu H$ ,  $I_{OUT} = 0A$

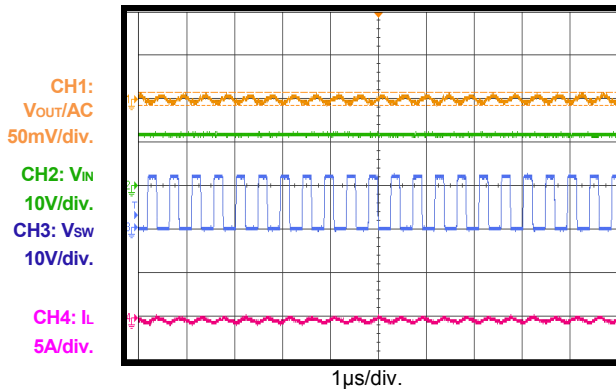

#### Output Ripple

$f_{SW} = 2.2MHz$ ,  $L = 2.2\mu H$ ,  $I_{OUT} = 6A$

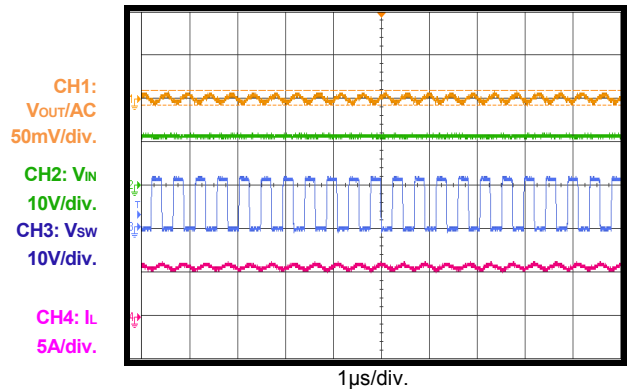

#### Power Start-Up

$I_{OUT} = 0A$

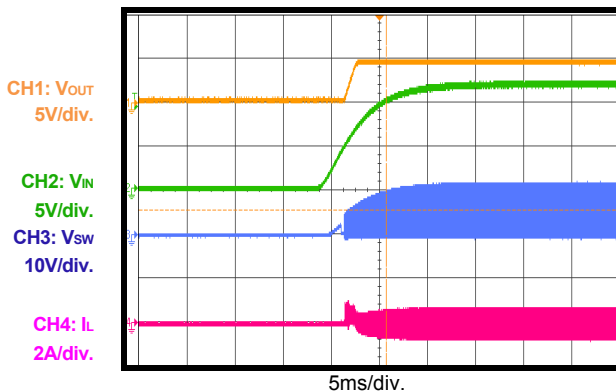

#### Power Start-Up

$I_{OUT} = 6A$

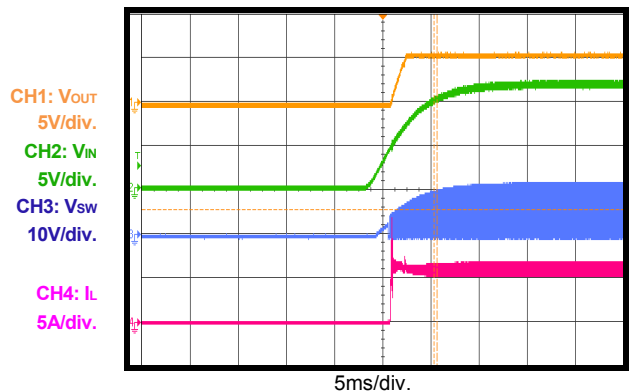

### TYPICAL PERFORMANCE CHARACTERISTICS (continued)

$V_{IN} = 12V$ ,  $V_{OUT} = 5V$ ,  $L = 4.7\mu H$ ,  $f_{SW} = 440kHz$ ,  $T_A = 25^\circ C$ , unless otherwise noted. All waveforms are tested based on bypassing the external MOSFET except Short Battery to Ground.

#### Power Shutdown

$I_{OUT} = 0A$

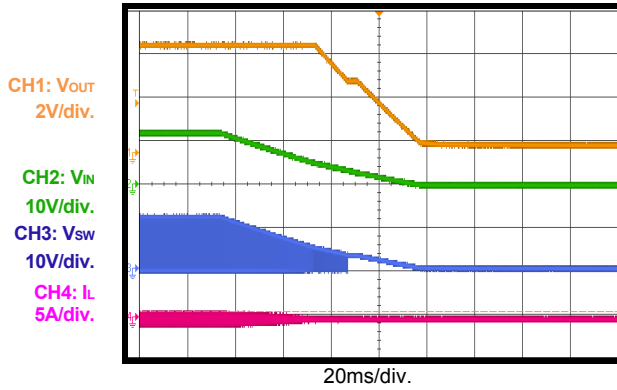

#### Power Shutdown

$I_{OUT} = 6A$

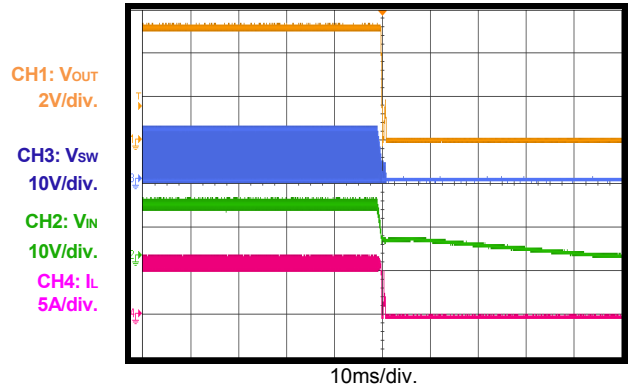

#### EN Start-Up

$I_{OUT} = 0A$

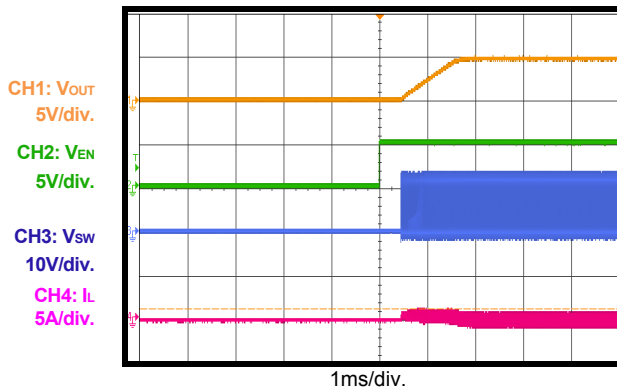

#### EN Start-Up

$I_{OUT} = 6A$

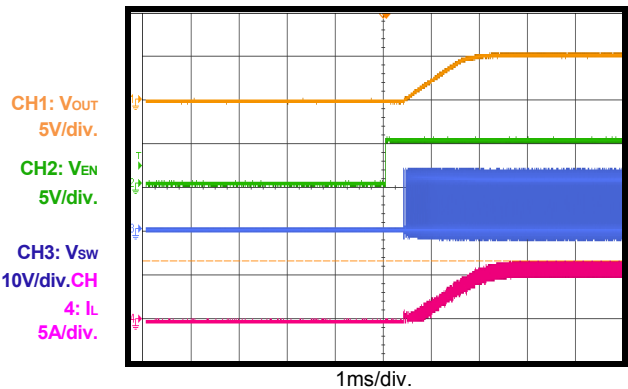

#### EN Shutdown

$I_{OUT} = 0A$

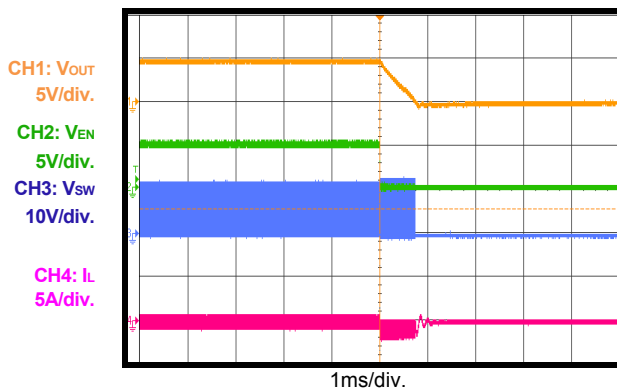

#### EN Shutdown

$I_{OUT} = 6A$

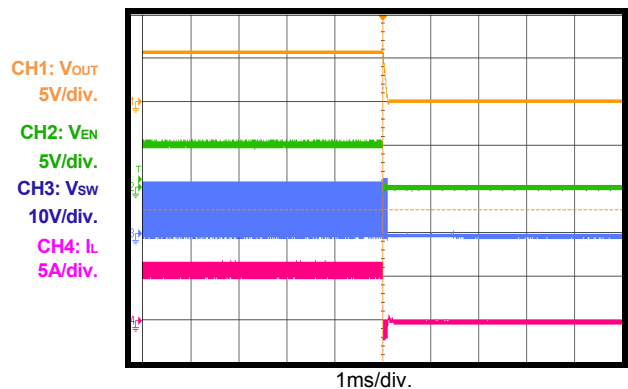

**TYPICAL PERFORMANCE CHARACTERISTICS (continued)**

$V_{IN} = 12V$ ,  $V_{OUT} = 5V$ ,  $L = 4.7\mu H$ ,  $f_{SW} = 440kHz$ ,  $T_A = 25^\circ C$ , unless otherwise noted. All waveforms are tested based on bypassing the external MOSFET except Short Battery to Ground.

**VOUT Short to USB\_GND Entry**

$I_{OUT} = 0A$

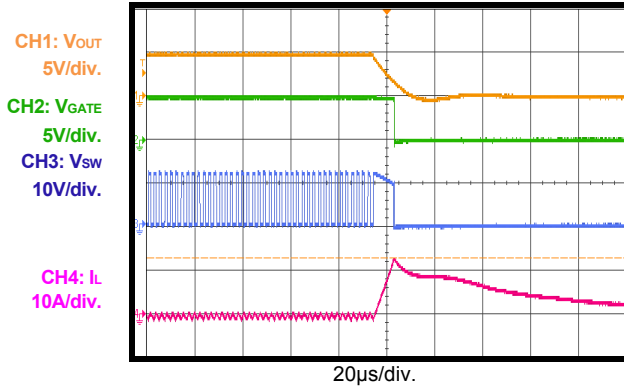

**VOUT Short to USB\_GND Steady State**

$I_{OUT} = 0A$

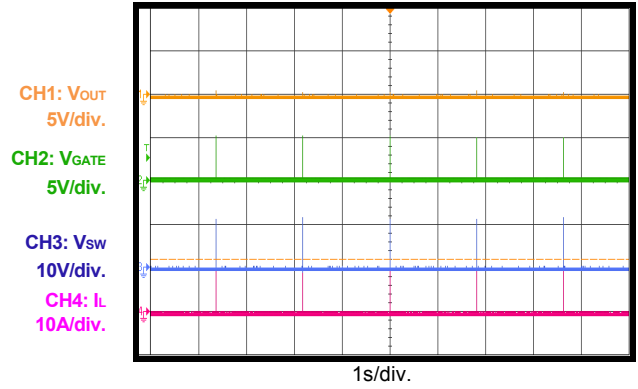

**VOUT Short to USB\_GND Recovery**

$I_{OUT} = 0A$

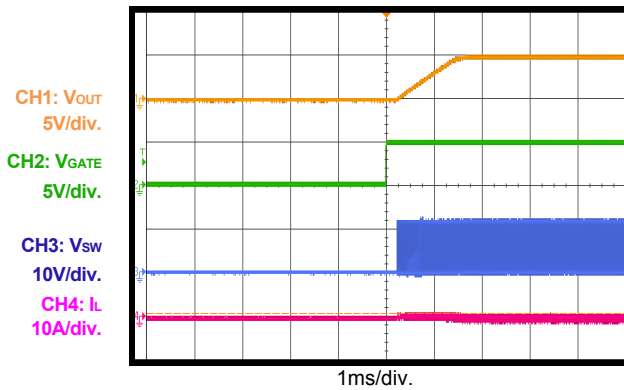

**USB\_GND Short to Battery Entry and Recovery**

$I_{OUT} = 0A$

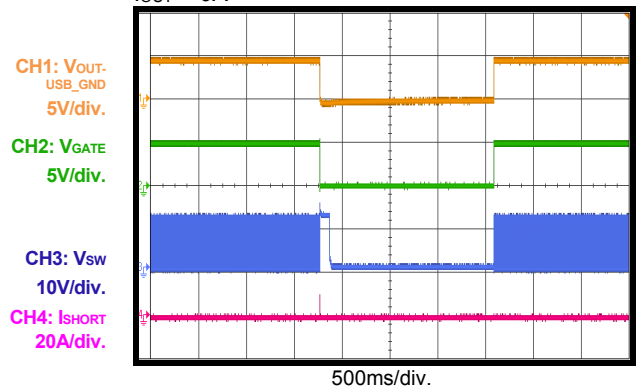

**Sync Function**

$f_{SW} = 300kHz$ ,  $L = 4.7\mu H$ ,  $I_{OUT} = 6A$

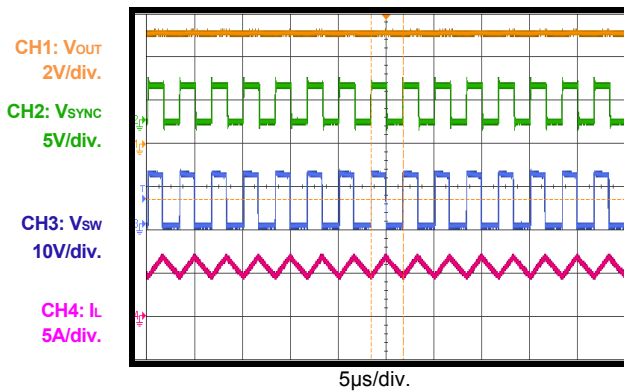

**Sync Function**

$f_{SW} = 2.1MHz$ ,  $L = 2.2\mu H$ ,  $I_{OUT} = 6A$

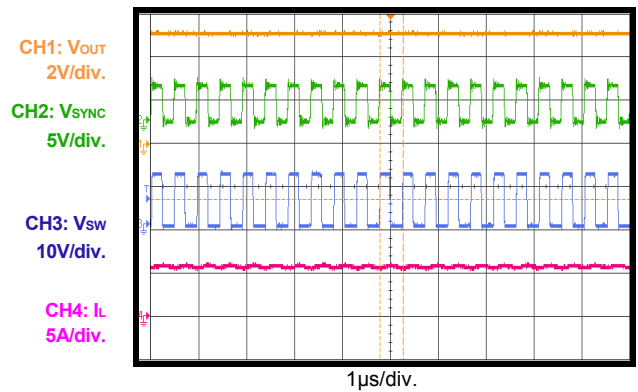

### TYPICAL PERFORMANCE CHARACTERISTICS *(continued)*

$V_{IN} = 12V$ ,  $V_{OUT} = 5V$ ,  $L = 4.7\mu H$ ,  $f_{SW} = 440kHz$ ,  $T_A = 25^\circ C$ , unless otherwise noted. All waveforms are tested based on bypassing the external MOSFET except Short Battery to Ground.

#### CC Mode Over-Current Protection Steady State

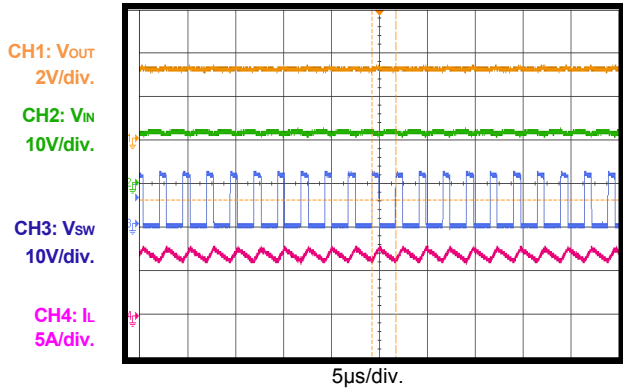

#### Low Dropout Mode

$V_{IN} = 5V$ ,  $V_{OUT} = 4.93V$ ,  $I_{OUT} = 0A$

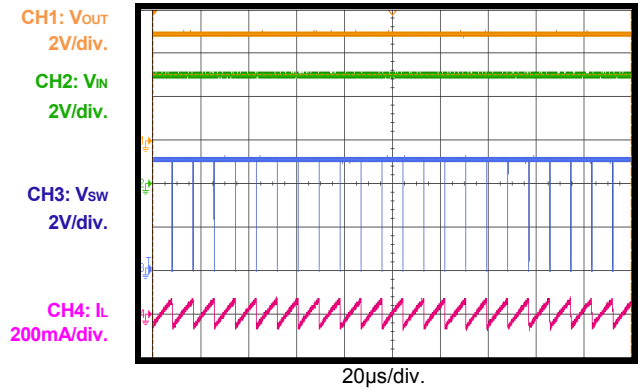

#### Load Transient

$I_{OUT} = 0$  to  $3A$ ,  $2.5A/\mu s$ ,  $V_{DROP} = GND$ ,  
line drop compensation =  $73mV @ 3A$

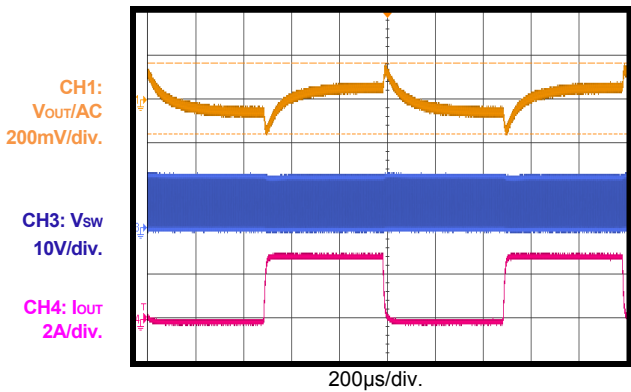

**FUNCTIONAL BLOCK DIAGRAM**

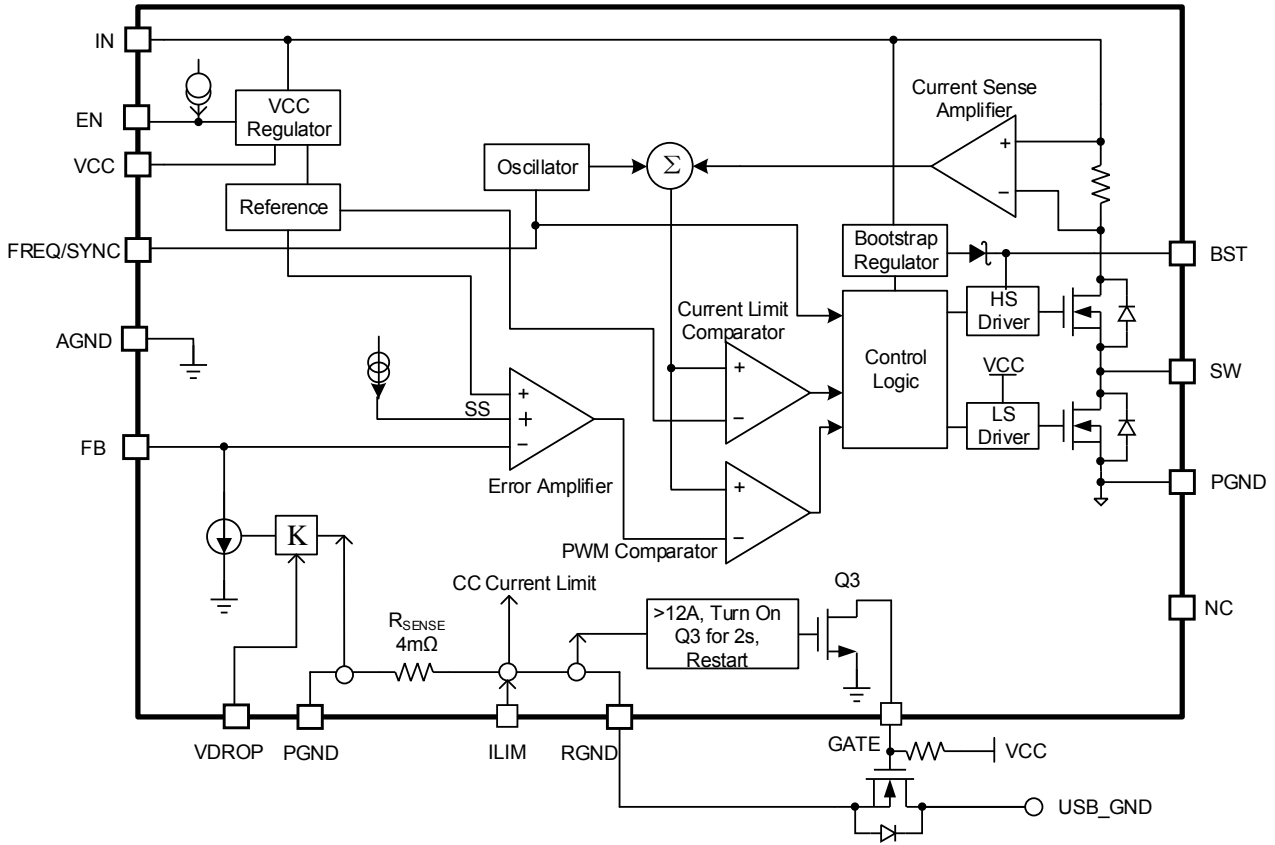

**Figure 1: Functional Block Diagram**

## OPERATION

The MPQ4480 integrates a monolithic, synchronous, rectified, step-down, switch-mode converter with internal power MOSFETs. It offers a compact solution to achieve 6A of continuous output current over a wide input supply range with excellent load and line regulation.

The MPQ4480 operates in a fixed-frequency, peak current mode control to regulate the output voltage. The internal clock initiates the PWM cycle, which turns on the integrated high-side MOSFET (HS-FET). The HS-FET remains on until its current reaches the value set by the COMP voltage. When the power switch is off, it remains off until the next clock cycle begins.

### Low-Dropout Operation

The operation frequency auto-decreases when the input voltage is close to the output voltage, helping the part achieve a low dropout voltage.

### Error Amplifier (EA)

The error amplifier (EA) compares the internal feedback voltage against the internal 1V reference (REF), and outputs a COMP voltage. This COMP voltage controls the power MOSFET current. The optimized internal compensation network minimizes the external component count and simplifies control loop design.

### Internal VCC Regulator

The 5.05V internal regulator powers most of the internal circuitries. This regulator takes  $V_{IN}$  and operates in the full  $V_{IN}$  range. When  $V_{IN}$  exceeds 5.05V, the output of the regulator is in full regulation. If  $V_{IN}$  is less than 5.05V, the output decreases with  $V_{IN}$ . VCC requires an external 1 $\mu$ F ceramic decoupling capacitor.

### Enable Control (EN)

The MPQ4480 has an enable control (EN). There is an internal 7 $\mu$ A pull-up current, which allows auto start-up if EN is floated. Pull EN high or float to enable the IC; pull EN low to disable the IC. EN is clamped internally using a 7.6V series Zener diode and a 10V breakdown voltage ESD cell (see Figure 2).

It is recommended to connect EN to  $V_{IN}$  and GND through divider resistors. When selecting

a pull-up resistor, ensure that it is large enough to limit the current flow into EN to below 100 $\mu$ A.

For example, if the EN pull-up resistor is 100k $\Omega$  and the pull-down resistor is 110k $\Omega$ , the IC will power up when  $V_{IN}$  exceeds the UVLO rising threshold.

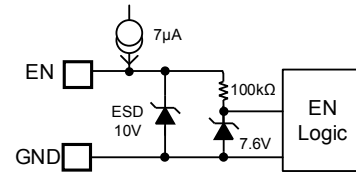

**Figure 2: Zener Diode Between EN and GND**

### Setting the Frequency

Connect a resistor from FREQ to ground to set the switching frequency. The value of the frequency can be estimated with Equation (1):

$$FREQ(kHz) = \frac{1000}{0.04 \times R_{FREQ}(k\Omega) + 0.1} \quad (1)$$

Figure 3 shows the frequency vs.  $R_{FREQ}$ .

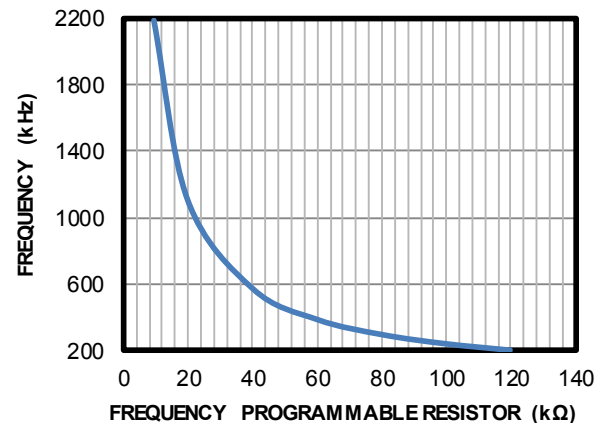

**Figure 3: Switching Frequency vs  $R_{FREQ}$**

For the MPQ4480, the FREQ pin cannot be left floating or tied to VCC or GND. FREQ should be connected to GND through a resistor.

To avoid tripping the minimum on time limitation in high-frequency and high input voltage conditions, the MPQ4480 employs frequency foldback. When  $f_{SW}$  exceeds 1.2MHz and  $V_{IN}$  is above 15V, the device decreases the switching frequency gradually until the frequency falls to half of the setting value.

### Frequency Spread Spectrum

The MPQ4480-FD is the switching frequency spread spectrum version of the MPQ4480. The purpose of spread spectrum is to minimize the peak emissions at a specific frequency.

The MPQ4480-FD uses a 4kHz triangle wave (rising 125 $\mu$ s, falling 125 $\mu$ s) to modulate the internal oscillator (see Figure 4). The frequency span of spread spectrum operation is  $\pm 10\%$ .

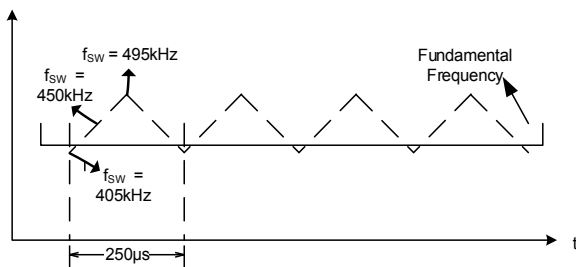

**Figure 4: Frequency Spread Spectrum**

The MPQ4480-FD frequency is only determined by internal trimming. It has no relationship with the FREQ pin's status.

### Frequency Synchronizing

The MPQ4480 can be synchronized to an external clock with a range from 300kHz to 2.1MHz through the SYNC pin, in series with a 10pF capacitor. The internal clock rising edge is synchronized to the external clock rising edge. A typical SYNC input signal should have a <25% duty cycle.

### Under-Voltage Lockout (UVLO)

Under-voltage lockout (UVLO) protects the chip from operating at an insufficient supply voltage. The UVLO comparator monitors the input voltage. The UVLO rising threshold is 3.95V; its falling threshold is 3.45V.

### Internal Soft Start (SS)

The soft start (SS) prevents the converter output voltage from overshooting during start-up. When the chip starts up, the internal circuitry generates a SS voltage that ramps up from 0V to 5.05V. When  $V_{SS}$  is lower than  $V_{REF}$ , the error amplifier uses  $V_{SS}$  as the reference. When  $V_{SS}$  is higher than  $V_{REF}$ , the error amplifier uses  $V_{REF}$  as the reference. The SS time is internally set to 1.1ms.

If the output of the MPQ4480 is pre-biased to a certain voltage during start-up, the IC disables

the switching of both the high-side and low-side switches until the voltage on the internal SS capacitor exceeds the internal feedback voltage.

### EN Shutdown Discharge

When EN is pulled low, the MPQ4480 enters output discharge mode. Meanwhile, the internal soft-start capacitor starts to discharge. The part remains in discharge mode until the soft-start capacitor discharges to very low.

In this mode, the low-side switch remains on until the low-side current reaches -2A, then turns on again after a clock cycle.

### CC Mode Over-Current Protection

The MPQ4480 senses the ground current and uses this information to limit output current below a certain threshold. If  $I_{OUT}$  exceeds the set current-limit threshold, the MPQ4480 enters constant current limit mode (CC mode). In this mode, the current amplitude is limited. As the load resistance reduces, the output voltage drops until the feedback voltage falls below the under-voltage (UV) threshold (typically 30% below the reference).

Once UV triggers, the MPQ4480 enters hiccup mode to periodically restart the part. This protection mode is especially useful when the output is dead-short to ground. This greatly reduces the average short-circuit current, alleviates thermal issues, and protects the regulator. The MPQ4480 exits hiccup mode once the over-current condition is removed.

In addition to the ground current limit, the MPQ4480 also has a high-side peak current limit.

Pulling the ILIM pin to GND, to VCC, or floating it can set three different CC current-limit thresholds.

### Over-Voltage Protection (OVP)

The MPQ4480 monitors a resistor-divided feedback voltage to detect over-voltage. When the feedback voltage ( $V_{FB}$ ) exceeds 115% of the target voltage, the controller enters a dynamic regulation period. During this period, the LS-FET remains on until its current goes to -2A. This discharges the output and tries to keep it within the normal range. If the OV still exists, the LS-FET turns on again after an 800ns delay. The part exits this regulation period when  $V_{FB}$

falls below 105% of  $V_{REF}$ . During OV protection, if the input voltage reaches 40V, the MPQ4480 stops the OVP discharge function until  $V_{IN}$  drops to 38V.

### RGND Short to Battery Protection

The MPQ4480 supports USB\_GND short to battery protection. The USB\_GND should be connected to the RGND through an N-MOSFET. The MPQ4480 senses the current from RGND to PGND, and the GATE pin is pulled low to turn off the N-MOSFET when the RGND-to-PGND current is above 12A. If RGND shorts to battery, the buck stops switching. When the battery short to ground is removed, the MPQ4480 resumes normal operation.

### Output Line Drop Compensation

The MPQ4480 is capable of compensating an output voltage drop, such as high impedance caused by a long trace, to keep a fairly constant load-side voltage.

The MPQ4480 uses the sensed load current through the internal ground current sensing MOSFET to sink a current ( $I_{FB}$ ) at the FB pin (see Figure 5).

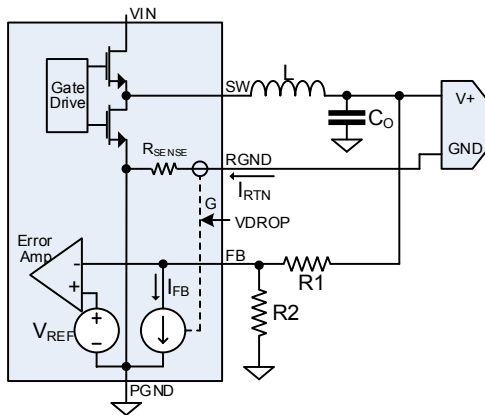

**Figure 5: Output Line Drop Compensation Circuit**

Calculate the feedback current with Equation (2):

$$I_{FB} = G \cdot I_{RTN} \quad (2)$$

$V_O$  can be calculated with Equation (3):

$$V_{OUT} = \left( \frac{R_1}{R_2} + 1 \right) V_{REF} + R_1 G \cdot I_{RTN} \quad (3)$$

The line drop compensation amplitude at certain output current condition is equal to  $R_1 \cdot I_{FB}$ .

$G \cdot I_{OUT}$ . The VDROP pin can program three gain levels, as the specification table shows.

The  $R_1$  value can also be used to adjust the line drop compensation amplitude. For example, at 3A output current, pull  $V_{DROP} = 0$  and select 40.2k $\Omega$  for  $R_1$  for the line drop compensation to be ~73mV (typically).

### Floating Driver and Bootstrap Charging

An external bootstrap capacitor powers the floating power MOSFET driver. This floating driver has its own UVLO protection. The UVLO's rising threshold is 2.2V, with a hysteresis of 150mV. The bootstrap capacitor voltage is regulated internally by  $V_{IN}$  and  $V_{CC}$  through  $D_1$ ,  $D_2$ ,  $M_1$ ,  $C_4$ ,  $L_1$ , and  $C_2$  (see Figure 6). The BST capacitor ( $C_4$ ) voltage is charged quickly by turning on  $M_1$  when the low-side switch is turned on. The 2.5 $\mu$ A input to the BST current source also charges the BST capacitor when the low-side switch does not turn on.

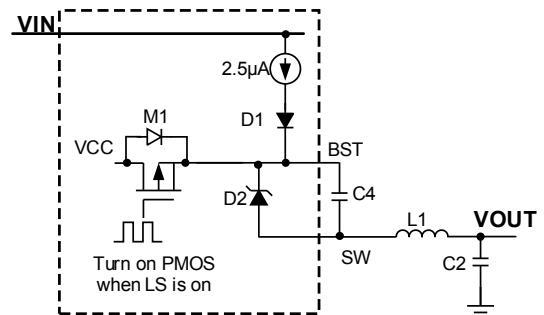

**Figure 6: Internal Bootstrap Charging Circuit**

### Start-Up and Shutdown

If both  $V_{IN}$  and  $EN$  exceed their respective thresholds, the chip is enabled. The reference block starts first, generating a stable reference voltage and currents, and then the internal regulator is enabled. The regulator provides a stable supply for the remaining circuitries.

Several events can shut down the chip:  $EN$  low,  $V_{IN}$  low, and thermal shutdown. In shutdown, the signaling path is blocked to avoid any fault triggering. Then the COMP voltage and the internal supply rail are pulled down. The floating driver is not subject to this shutdown command.

### Thermal Shutdown (TSD)

Thermal shutdown prevents the chip from operating at exceedingly high temperatures.





When the silicon die temperature exceeds 165°C, it shuts down the entire chip. When the temperature falls below its lower threshold (typically 145°C), the chip is enabled.

## APPLICATION INFORMATION

### COMPONENT SELECTION

#### Setting the Output Voltage

The external resistor divider sets the output voltage (see Typical Application on page 2). The feedback resistor (R1) also sets the feedback loop bandwidth with the internal compensation capacitor. R2 is determined with Equation (4):

$$R2 = \frac{R1}{\frac{V_{OUT}}{1V} - 1} \quad (4)$$

Figure 7 shows the external resistor divider.

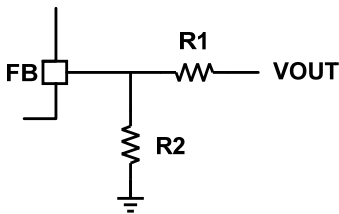

**Figure 7: Feedback Network**

Table 1 lists the recommended resistor values for common output voltages.

**Table 1: Resistor Selection for Common Output Voltages**

V <sub>OUT</sub> (V)	R1 (kΩ)	R2 (kΩ)
3.3	40.2	17.4
5	40.2	10
9	40.2	4.99

#### Selecting the Inductor

For most applications, use an inductor with a DC current rating at least 25% higher than the maximum load current. Select an inductor with a small DC resistance for optimum efficiency. The inductor value for most designs can be calculated with Equation (5):

$$L_1 = \frac{V_{OUT} \times (V_{IN} - V_{OUT})}{V_{IN} \times \Delta I_L \times f_{OSC}} \quad (5)$$

Where  $\Delta I_L$  is the inductor ripple current.

Choose the inductor ripple current to be approximately 30% of the maximum load current. The maximum inductor peak current can be determined with Equation (6):

$$I_{L(MAX)} = I_{LOAD} + \frac{\Delta I_L}{2} \quad (6)$$

#### Selecting the Buck Input Capacitor

The step-down converter has a discontinuous input current, and requires a capacitor to supply the AC current while maintaining the DC input voltage. Use low-ESR capacitors for optimal performance. Ceramic capacitors with X5R or X7R dielectrics are highly recommended because of their low ESR and small temperature coefficients. For CLA application, a 100μF electrolytic capacitor and two 10μF ceramic capacitors are recommended.

Since the input capacitor (C1) absorbs the input switching current, it requires an adequate ripple-current rating. The RMS current in the input capacitor can be estimated with Equation (7):

$$I_{C1} = I_{LOAD} \times \sqrt{\frac{V_{OUT}}{V_{IN}} \times \left(1 - \frac{V_{OUT}}{V_{IN}}\right)} \quad (7)$$

The worst-case condition occurs at  $V_{IN} = 2V_{OUT}$ , which can be calculated with Equation (8):

$$I_{C1} = \frac{I_{LOAD}}{2} \quad (8)$$

For simplification, choose an input capacitor with an RMS current rating greater than half of the maximum load current.

The input capacitor can be electrolytic, tantalum, or ceramic. When using an electrolytic capacitor, place two additional high-quality ceramic capacitors as close to IN as possible. Estimate the input voltage ripple caused by the capacitance with Equation (9):

$$\Delta V_{IN} = \frac{I_{LOAD}}{f_{SW} \times C1} \times \frac{V_{OUT}}{V_{IN}} \times \left(1 - \frac{V_{OUT}}{V_{IN}}\right) \quad (9)$$

#### Selecting the Buck Output Capacitor

The MPQ4480 requires an output capacitor (C2) to maintain the DC output voltage. Estimate the output voltage ripple with Equation (10):

$$\Delta V_{OUT} = \frac{V_{OUT}}{f_{SW} \times L_1} \times \left(1 - \frac{V_{OUT}}{V_{IN}}\right) \times \left(R_{ESR} + \frac{1}{8 \times f_s \times C2}\right) \quad (10)$$

Where  $L_1$  is the inductor value and  $R_{ESR}$  is the equivalent series resistance (ESR) value of the output capacitor.

For an electrolytic capacitor, the ESR dominates the impedance at the switching frequency. For simplification, the output ripple can be estimated with Equation (11):

$$\Delta V_{OUT} = \frac{V_{OUT}}{f_{SW} \times L_1} \times \left(1 - \frac{V_{OUT}}{V_{IN}}\right) \times R_{ESR} \quad (11)$$

For polymer capacitor designs, the ESR of output capacitor should be less than 50mΩ.

### PCB Layout Guidelines <sup>(8)</sup>

Proper PCB layout is critical for efficient operation and thermal dissipation. For best results, refer to Figure 8 and follow the guidelines below:

1. Place the high-current paths (GND, IN, and SW) very close to the device with short, direct, and wide traces.
2. Use a large copper plane for PGND. Add multiple vias to improve thermal dissipation.
3. Connect AGND to PGND.
4. Ensure that FB is far from SW to avoid noise.
5. To improve EMI performance, place two ceramic input decoupling capacitors as close as possible to IN and PGND.
6. Place the VCC decoupling capacitor as close as possible to VCC.

**Note:**

- 8) The recommended layout is based on the Typical Application Circuits on page 19.

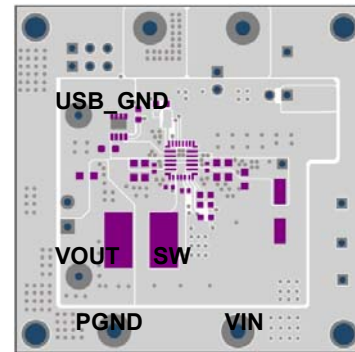

**Top Layer**

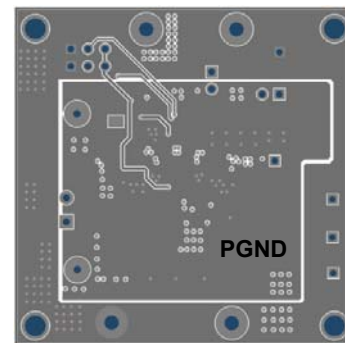

**PGND  
Middle Layer 1**

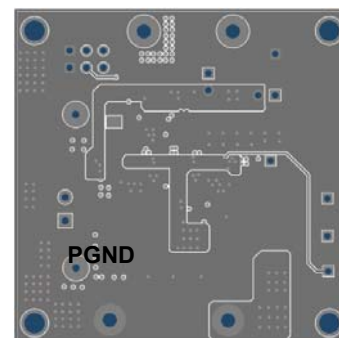

**Middle Layer 2**

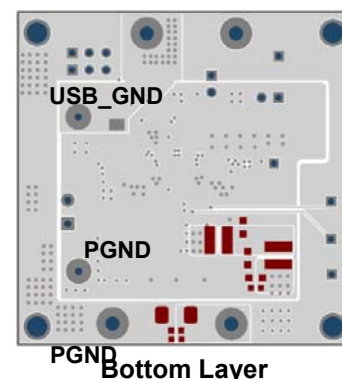

**PGND  
Bottom Layer**

**Figure 8: Recommend Layout**

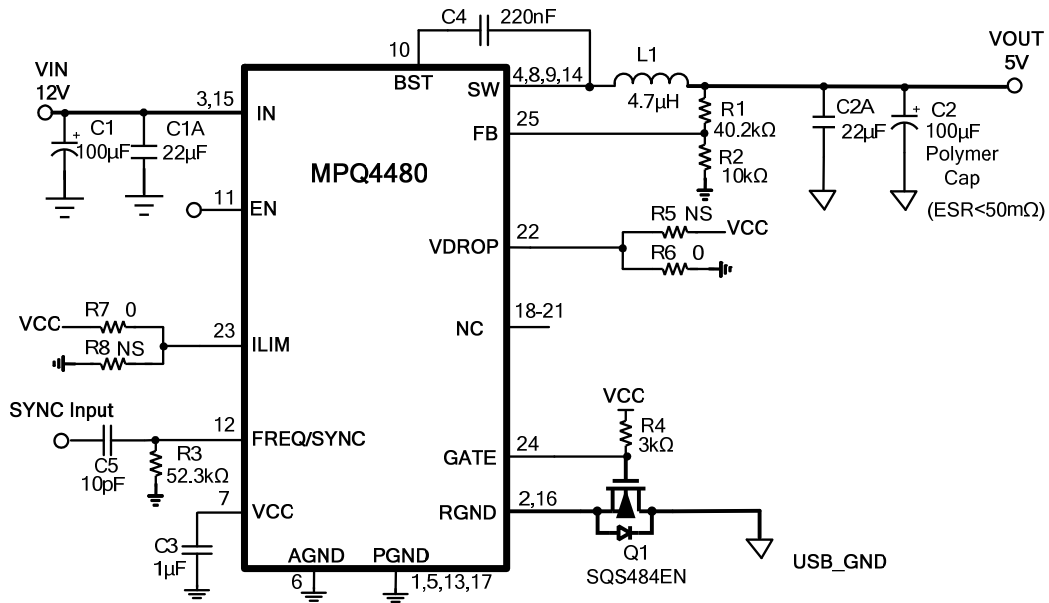
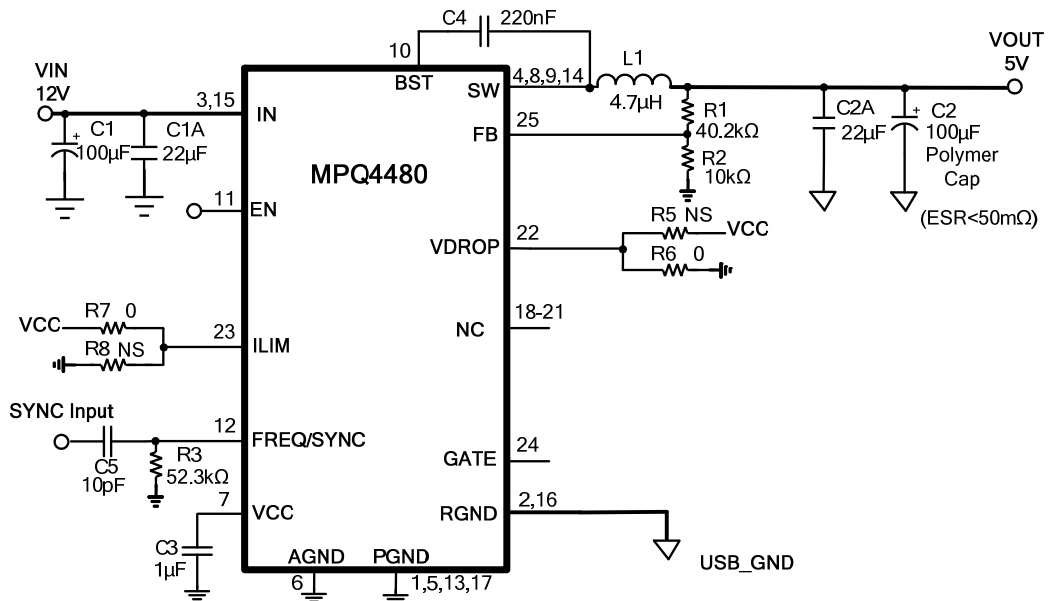
**TYPICAL APPLICATION CIRCUITS**

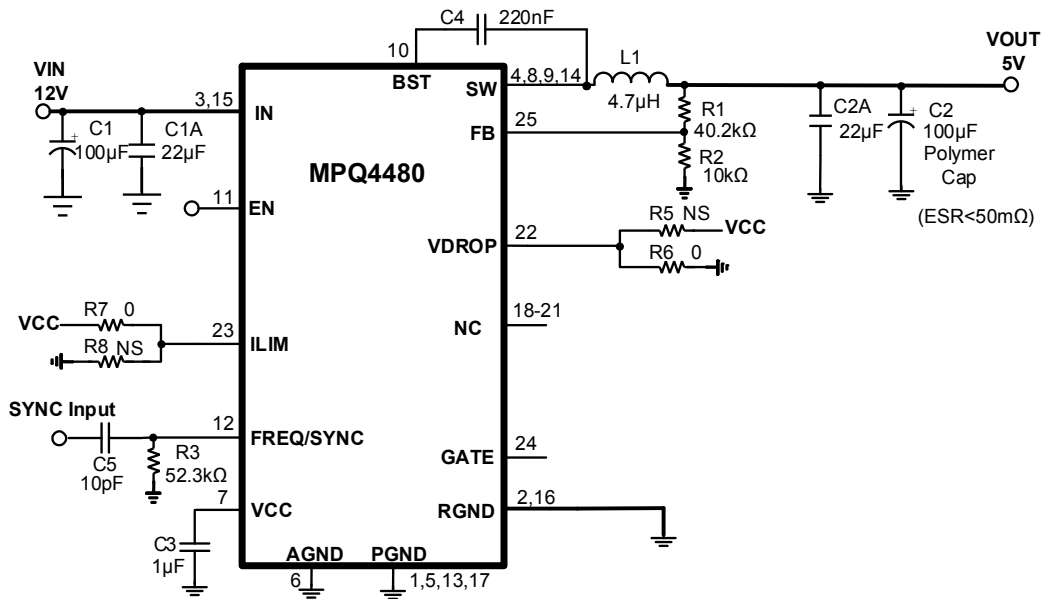
**Figure 9:  $V_{IN} = 12V$ ,  $V_{OUT} = 5V$ ,  $I_{OUT} = 6A$ ,  $f_{sw} = 440kHz$ , with GND short to battery protection**

**Figure 10:  $V_{IN} = 12V$ ,  $V_{OUT} = 5V$ ,  $I_{OUT} = 6A$ ,  $f_{sw} = 440kHz$ , without GND short to battery protection**

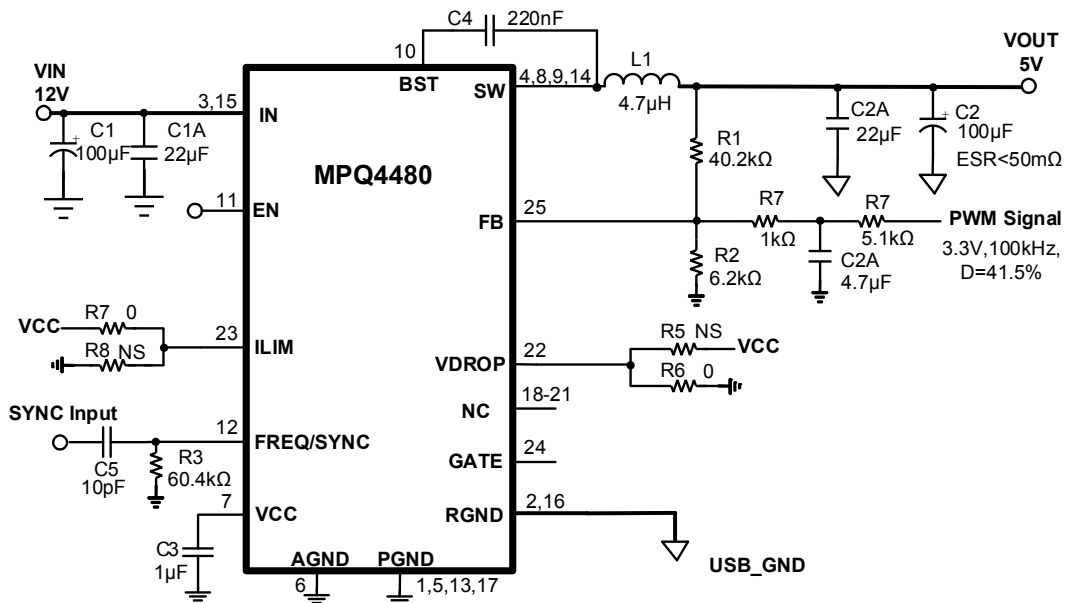

**Figure 11:  $V_{IN} = 12V$ ,  $V_{OUT} = 5V$ ,  $I_{OUT} = 6A$ ,  $f_{sw} = 440kHz$ , without CC protection, only buck peak OCP**



**Figure 12:  $V_{IN} = 12V$ ,  $V_{OUT} = 1V$  to  $11V$  (5V default),  $I_{OUT} = 6A$ ,  $f_{sw} = 380kHz$ , wireless charging application**

## PACKAGE INFORMATION

### QFN-25 (4mm x 5mm)

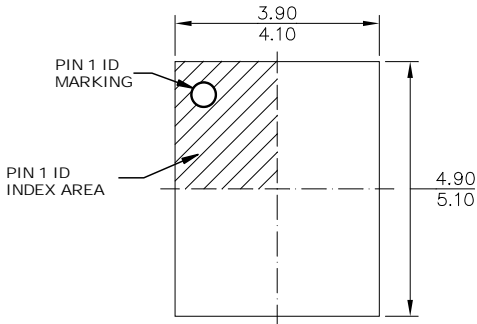

TOP VIEW

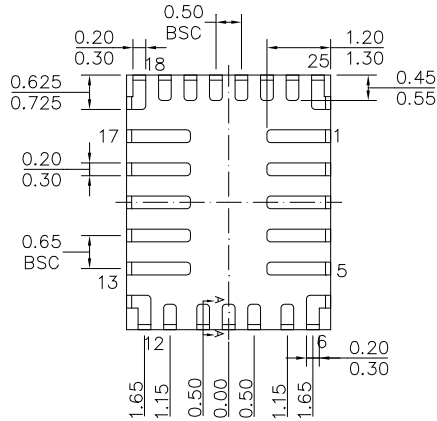

BOTTOM VIEW

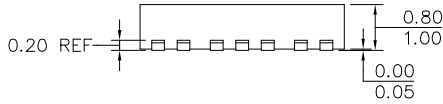

SIDE VIEW

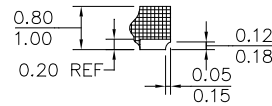

SECTION A-A

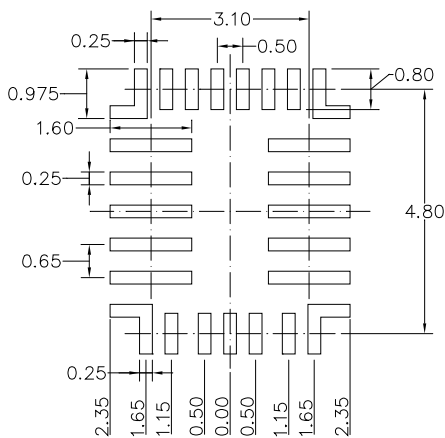

RECOMMENDED LAND PATTERN

**NOTE:**

- 1) THE LEAD SIDE IS WETTABLE.
- 2) LAND PATTERNS OF PIN1~5 AND 13~17 HAVE THE SAME LENGTH AND WIDTH.
- 3) ALL DIMENSIONS ARE IN MILLIMETERS.
- 4) LEAD COPLANARITY SHALL BE 0.08 MILLIMETERS MAX.
- 5) JEDEC REFERENCE IS MO-220.
- 6) DRAWING IS NOT TO SCALE.

**NOTICE:** The information in this document is subject to change without notice. Users should warrant and guarantee that third-party Intellectual Property rights are not infringed upon when integrating MPS products into any application. MPS will not assume any legal responsibility for any said applications.