

OF5027

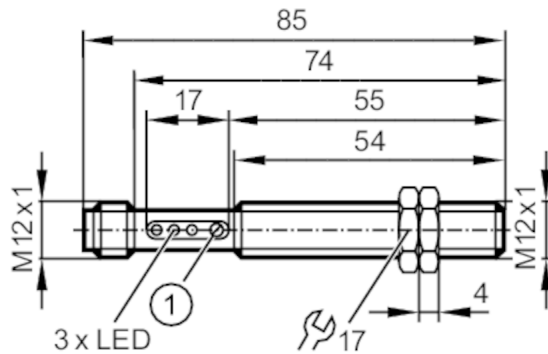

Diffuse reflection sensor

OFB-FPKG/US-100



1 potentiometer



Product characteristics

Type of light	infrared light
Housing	threaded type
Dimensions [mm]	M12 x 1 / L = 74

Application

Special feature	Function check output
Function principle	Diffuse reflection sensor

Electrical data

Operating voltage [V]	10...36 DC
Current consumption [mA]	< 35
Protection class	II
Reverse polarity protection	yes
Type of light	infrared light
Wave length [nm]	880

Outputs

Electrical design	PNP
Output function	light-on/dark-on mode; (programmable)
Max. voltage drop switching output DC [V]	2.5
Function check output	yes
Max. voltage drop of function check output [V]	3.5
Max. current load for function check output [mA]	10
Permanent current rating of switching output DC [mA]	200
Switching frequency DC [Hz]	320
Short-circuit protection	yes
Type of short-circuit protection	pulsed
Overload protection	yes

OF5027



Diffuse reflection sensor

OFB-FPKG/US-100

Detection zone		
Range	[mm]	1...400; (white paper 200 x 200 mm)
Range adjustable		yes
Max. light spot diameter	[mm]	185
Light spot dimensions refer to		at maximum range
Operating conditions		
Ambient temperature	[°C]	-25...60
Protection		IP 65
Tests / approvals		
EMC		EN 60947-5-2
MTTF	[years]	607
Mechanical data		
Weight	[g]	46.6
Housing		threaded type
Dimensions	[mm]	M12 x 1 / L = 74
Thread designation		M12 x 1
Materials		brass white bronze coated
Lens material		PMMA
Displays / operating elements		
Display	switching status	1 x LED, yellow
	operation	1 x LED, green
	function	1 x LED, red
Accessories		
Accessories (supplied)		lock nuts: 2 x screwdrivers
Remarks		
Pack quantity		1 pcs.
Electrical connection		
Connector: 1 x M12		
		



Diffuse reflection sensor

OFB-FPKG/US-100

Connection

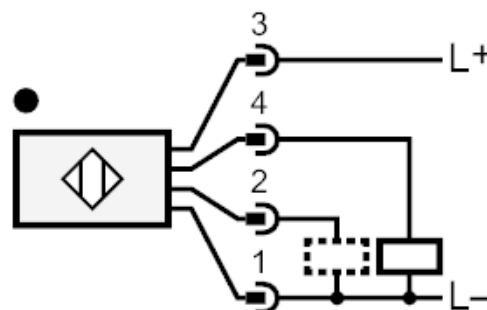
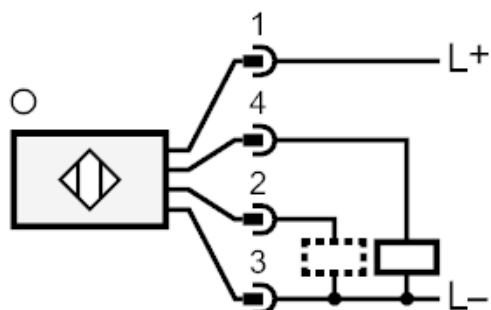

2 Function check output

Diagrams and graphs

excess gain graph

