

## SPECIFICATION

Part No. : **CAB.S01**

Product Name : Taoglas Cable Assembly  
IPEX MH4(HSC comp) to SMA(F)Bulkhead Straight Connector  
with 100mm  $\varnothing$ 0.81 cable



## 1. Cable Insertion Loss

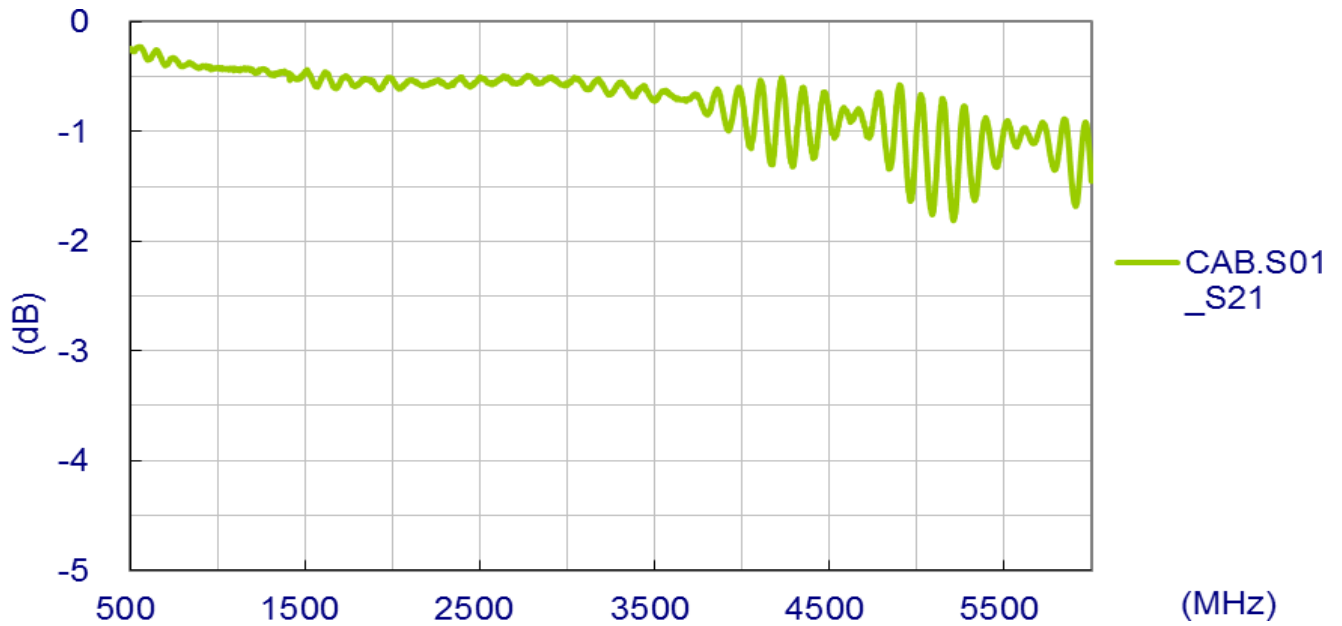

## 2. 0.81 Cable Specification

### 2.1 Drawing – Cross Section

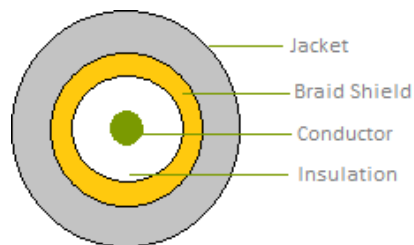

## 2.2 Structure and Dimensions

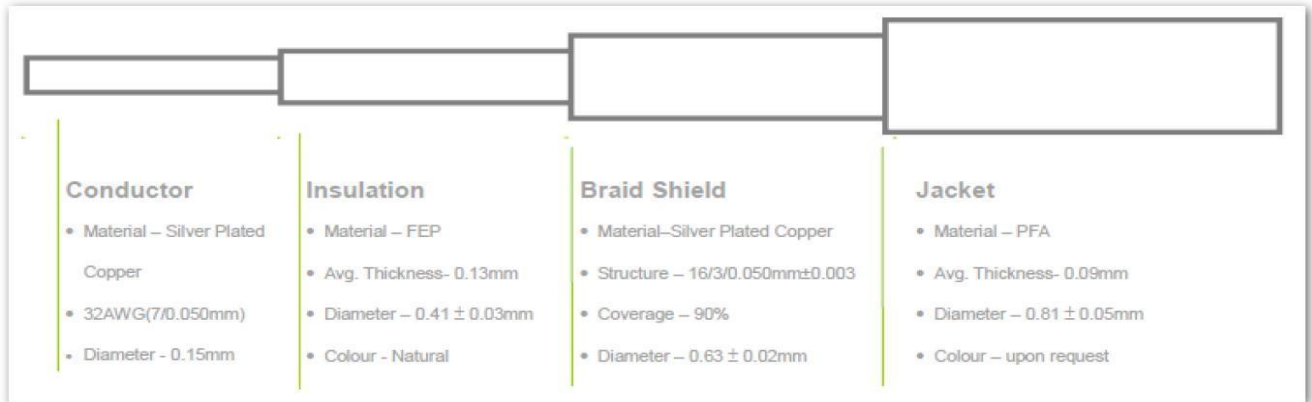

## 2.3 Electrical & Physical Specification

1	Insulation Resistance:	1000 MEGA OHM-KM Min.
2	Conductor Resistance:	1400 OHM/KM/20°C Max.
3	Dielectric Strength:	AC 1.0 KV/minute
4	Spark test:	2.5 KV
5	Nom. Impedance	50 ± 3 Ohms
6	Nom. Capacitance	97 ± 3 pF/m
7	Attenuation (dB/1M)	2.0GHz    3.60 2.4GHz    5.10 3.0GHz    6.20 4.0GHz    7.50 5.0GHz    8.50 6.0GHz    9.40

### 3. Technical Drawing

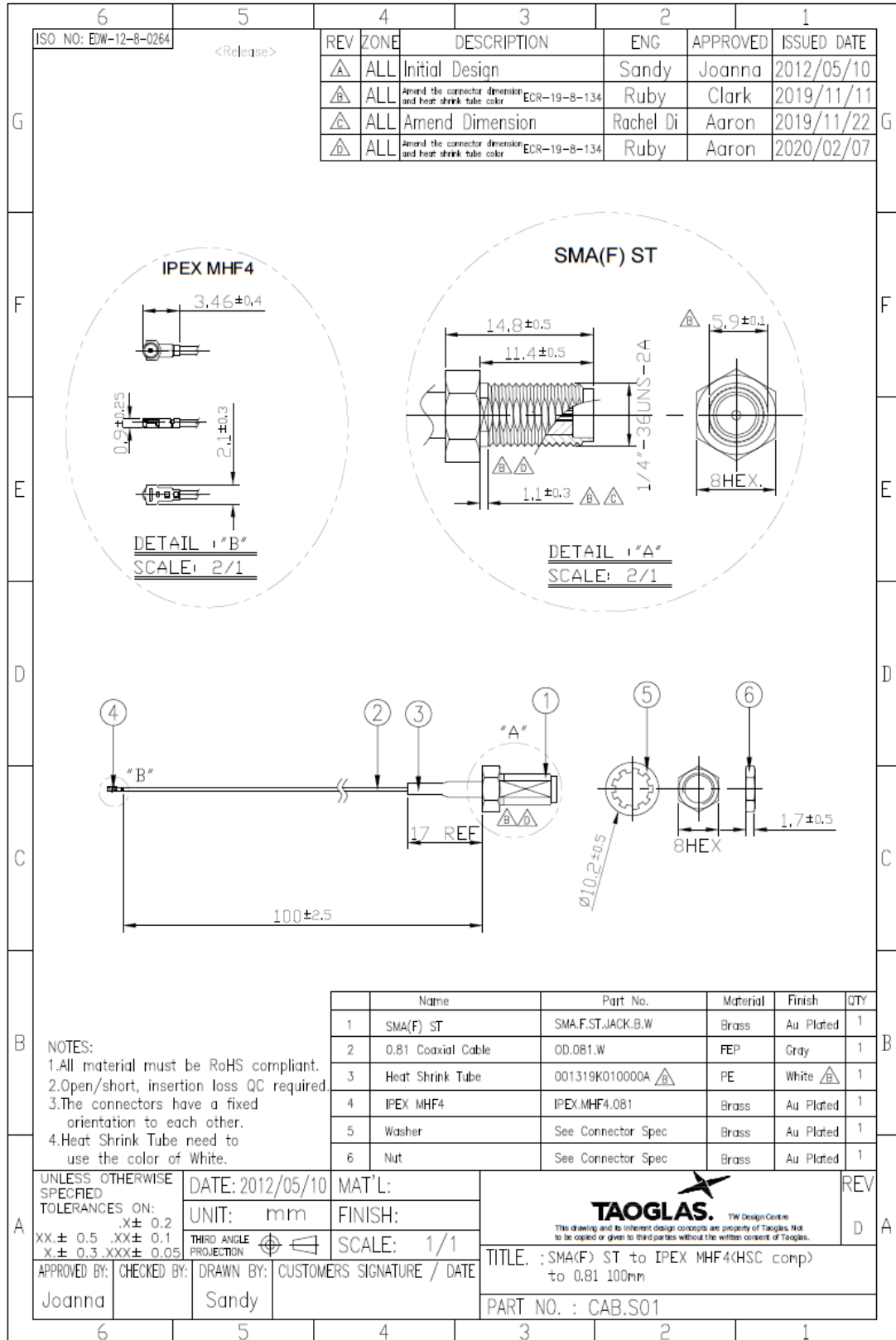

## 4. Packaging

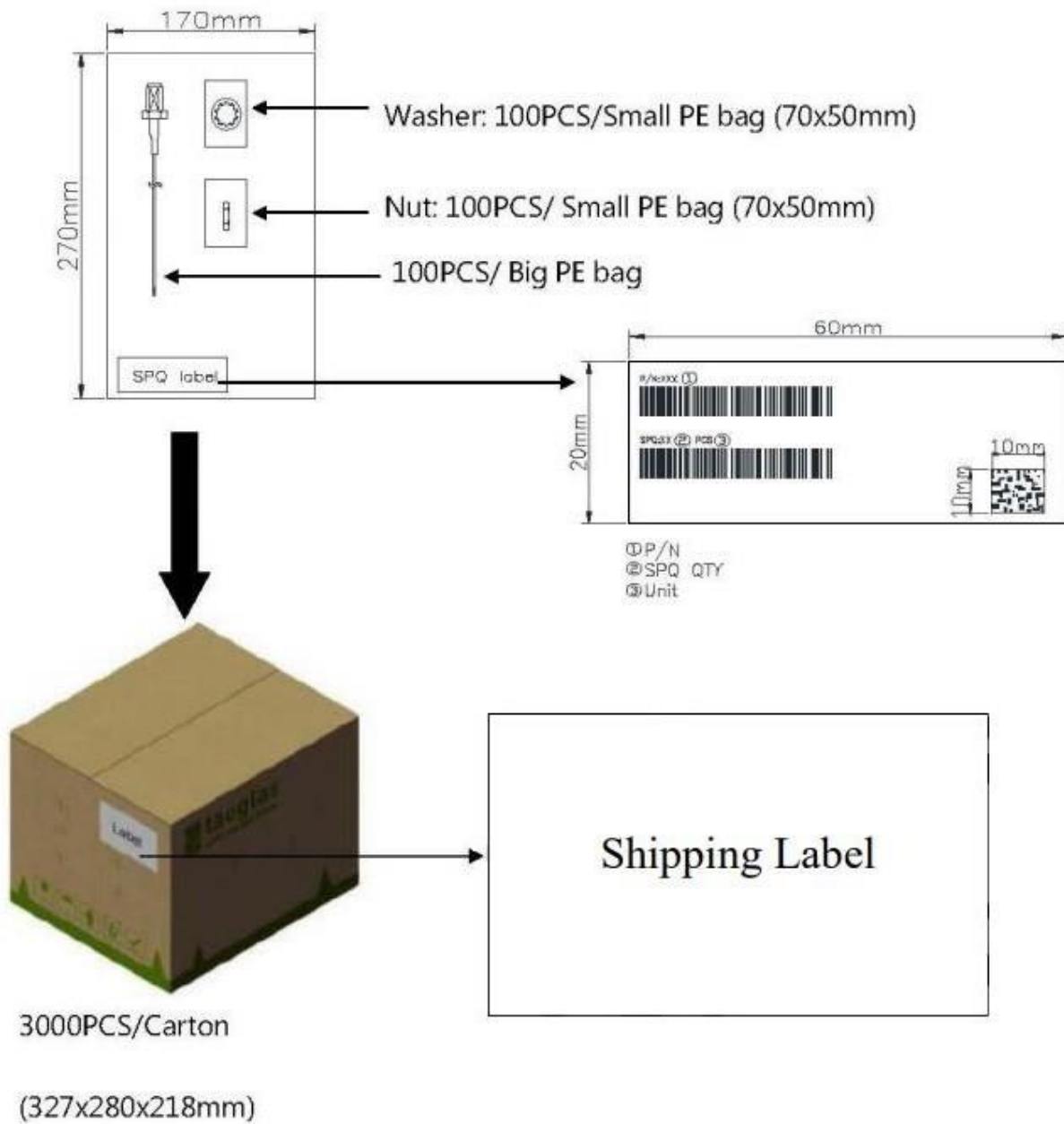

Taoglas makes no warranties based on the accuracy or completeness of the contents of this document and reserves the right to make changes to specifications and product descriptions at any time without notice.

Taoglas reserves the rights to this document and the information contained herein. Reproduction, use or disclosure to third parties without express permission is strictly prohibited.

© Taoglas