

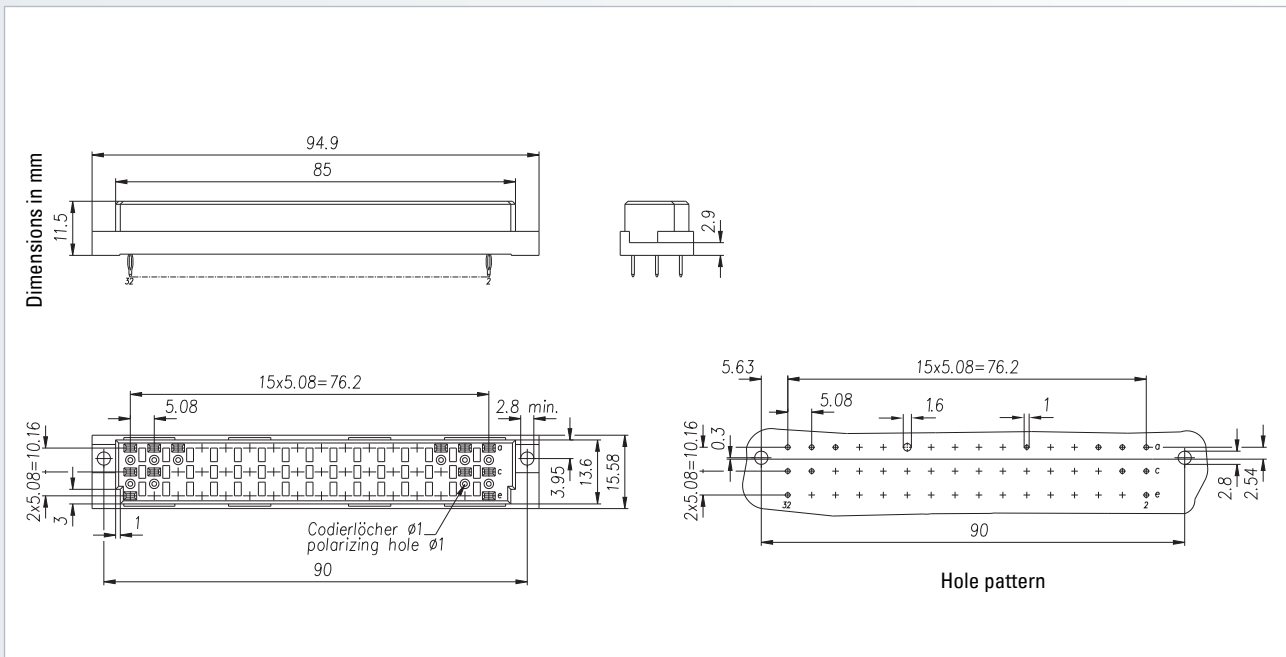

Connectors according to DIN 41612 / IEC 60603-2

Type E

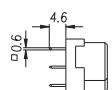

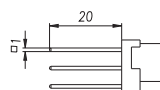
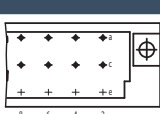
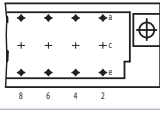

Female connector

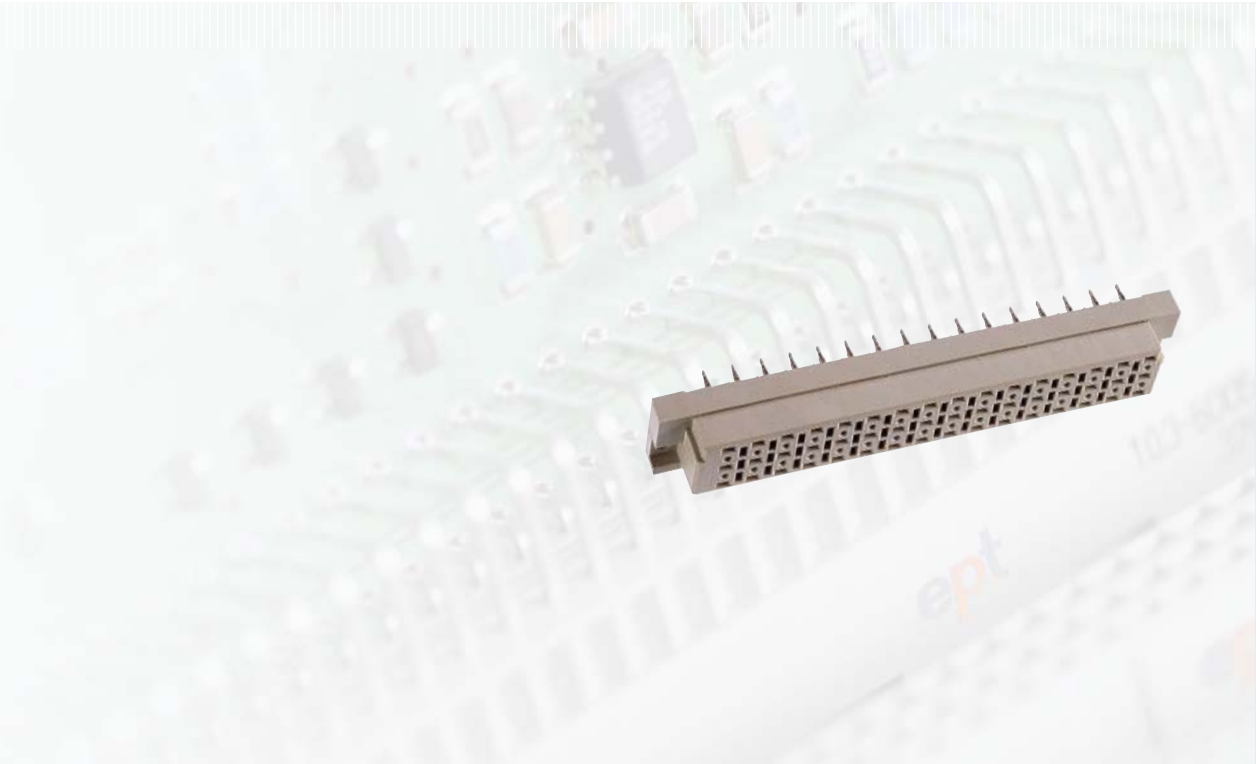

No. of contacts	Contact arrangement	Press-fit technology – Performance level II	
		Termination length	
			
Part number			
32		108-60054	108-60015
32		108-60044	108-60025
48		108-60084	108-60065

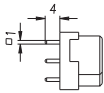
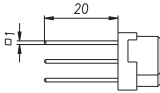
Accessories	On request	Options
<ul style="list-style-type: none"> – Press-fit tool (see page 208) – Support tool (see page 209) – Coding accessories (see page 160) 	<ul style="list-style-type: none"> – Performance levels I + III or customer-specific – Special contact length 	<ul style="list-style-type: none"> – Without flange – Contact arrangement (see page 162)

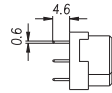

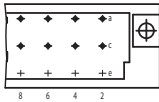
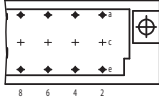
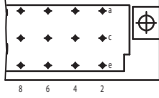
No. of contacts	Contact arrangement	Solder technology – Performance level II				
		Termination length				
						
Part number						
32		108-40014	108-40015	–	108-40044	108-40046
32		108-40024	108-40025	–	108-40034	108-40036
48		108-40064	108-40065	108-40084	108-40074	108-40076

Accessories – Coding accessories (see page 160)	On request – Performance levels I + III or customer-specific – Special contact length – Also in THTR	Options – Board lock (see page 159) – Contact arrangement (see page 162)
---	--	---