

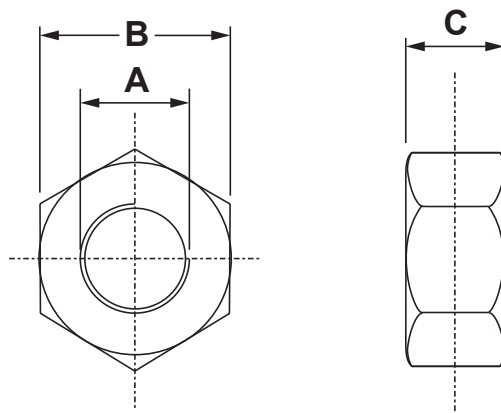

DIM.	TOL.
5mm DOWN	±0.2
5~20mm	±0.3
20~40mm	±0.4
40~60mm	±0.5
60 100mm	±0.8
100mm UP	±1.0

REVISIONS			
REV	DESCRIPTION	DATE	BY



P/N	A	B	C	DIN
10411AA00	M 2	4,0	1,2	34814
10412AA00	M 2,5	5,0	2,0	34814
10413AA00	M 3	6,0	2,15 - 2,4	34814
10414AA00	M 4	7,0	3,2	34814
10415AA00	M 5	8,0	4,0	34814
10416AA00	M 6	10,0	5,0	34814
10417AA00	M 8	13,0	6,4	34814
10418AA00	M 10	17,0	8,0	555/934
10419AA00	M 12	19,0	10,1	555/934
10420AA00	M 14	21,0	12,8	34814
10421AA00	M 16	24,0	14,8	34814
10422AA00	M 20	30,0	18,0	34814
10423AA00	M 24	36,0	21,5	34814

**OPERATING TEMPERATURE: -30° C ~ + MAX. 100° C**  
**ESTIMATE ACCORDING: DIN EN ISO 34814**

		TITLE <b>HEXAGONAL NUT DIN 34814 (EX 555/934)</b>	
		MATERIAL PA6	DATE 19/02/2022
		COLOR NATURAL	DRAWN A.C.
PART NUMBER SEE TABLE		DRAWING NUMBER 22.01.19.1XXXX.0.E	
SIZE A4	SCALE NTS	UNIT mm	REV A
UNLESS OTHERWISE SPECIFIED TOLERANCE SEE ABOVE		APPROVED	