

- 1
- 2
- 3
- 4
- 5
- 6
- 7
- 8
- 9
- 10
- 11
- 12
- 13
- 14
- 15
- 16
- 17
- 18

MATERIAL

Glass-fibre reinforced polyamide based (PA) SUPER-technopolymer, black colour, matte finish.

ROTATING PIN

AISI 303 stainless steel.

STANDARD EXECUTIONS

- **CFM-L-A**: pass-through holes for countersunk-head screws, hinge bodies with the same dimensions.
- **CFM-L-B**: pass-through holes for countersunk-head screws, hinge bodies with different dimensions.

ROTATION ANGLE (APPROXIMATE VALUE)

Max 270° (-90° and +180° being 0° the condition where the two interconnected surfaces are on the same plane).

Do not exceed the rotation angle limit so as not to prejudice the hinge mechanical performance.

To choose the convenient type and the right number of hinges for your application, see the Guidelines (see page 952).

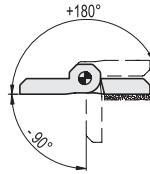

Resistance tests	Axial Stress	Radial Stress	90° Angled Stress
Description	Max limit static load Sa [N]	Max limit static load Sr [N]	Max limit static load S90 [N]
CFM-L-A.50-76 SH-6	600	1500	1000
CFM-L-A.60-120 SH-8	900	2300	700
CFM-L-B.50-63 SH-6	800	1600	1000
CFM-L-B.60-90 SH-8	1000	2000	800

The max static load is the value beyond which the material may break thus prejudicing the hinge performance. Obviously, a suitable coefficient must be applied to this value, according to the importance and the safety level of the specific application.

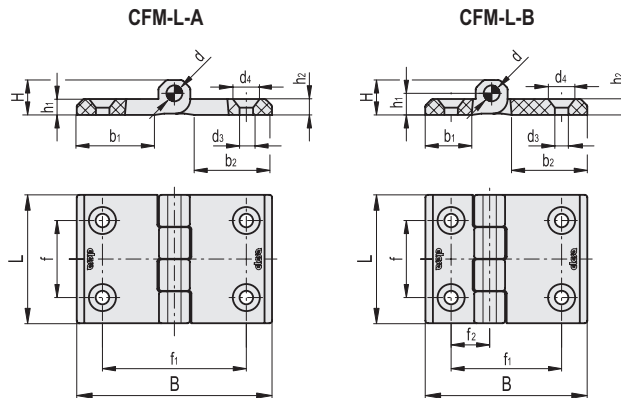

CFM-L-A

Code	Description	L	B	f1±0.25	f2±0.25	H	h1	h2	b1	b2	d	d3	d4	C# [Nm]	△
425856	CFM-L-A.50-76-SH-6	50	76	30	56	11.5	6.5	6	31	31	6	6.5	12.5	5	42
425818	CFM-L-A.60-120-SH-8	60	120	36	90	15	8.5	8	51	51	8	8.5	16.5	5	98

CFM-L-B

Code	Description	L	B	f1±0.25	f2±0.25	H	h1	h2	b1	b2	d	d3	d4	C# [Nm]	△	
425851	CFM-L-B.50-63-SH-6	50	63	30	43	15	11.5	6.5	6	18	31	6	6.5	12.5	5	37
425815	CFM-L-B.60-90-SH-8	60	90	36	63	18	15	8.5	8	21	51	8	8.5	16.5	5	80