



Part no.: 560342
BT-SET-240BCS
Mounting bracket set

Figure can vary

Contents

- Technical data
- Dimensioned drawings

Part no.: 560342 – BT-SET-240BCS – Mounting bracket set

Technical data

Basic data

Suitable for	MLD 500, MLD 300 multiple light beam safety devices
--------------	---

Mechanical data

Type of fastening, at system	Through-hole mounting
------------------------------	-----------------------

Type of fastening, at device	Clampable
------------------------------	-----------

Type of mounting device	Shock absorber Turning, 240°
-------------------------	---------------------------------

Mounting device material	Metal
--------------------------	-------

Classification

Customs tariff number	73269098
-----------------------	----------

eCl@ss 8.0	27279202
------------	----------

eCl@ss 9.0	27273701
------------	----------

ETIM 5.0	EC003015
----------	----------

ETIM 6.0	EC003015
----------	----------

Dimensioned drawings

All dimensions in millimeters

BT-SET-240BS swivel mount

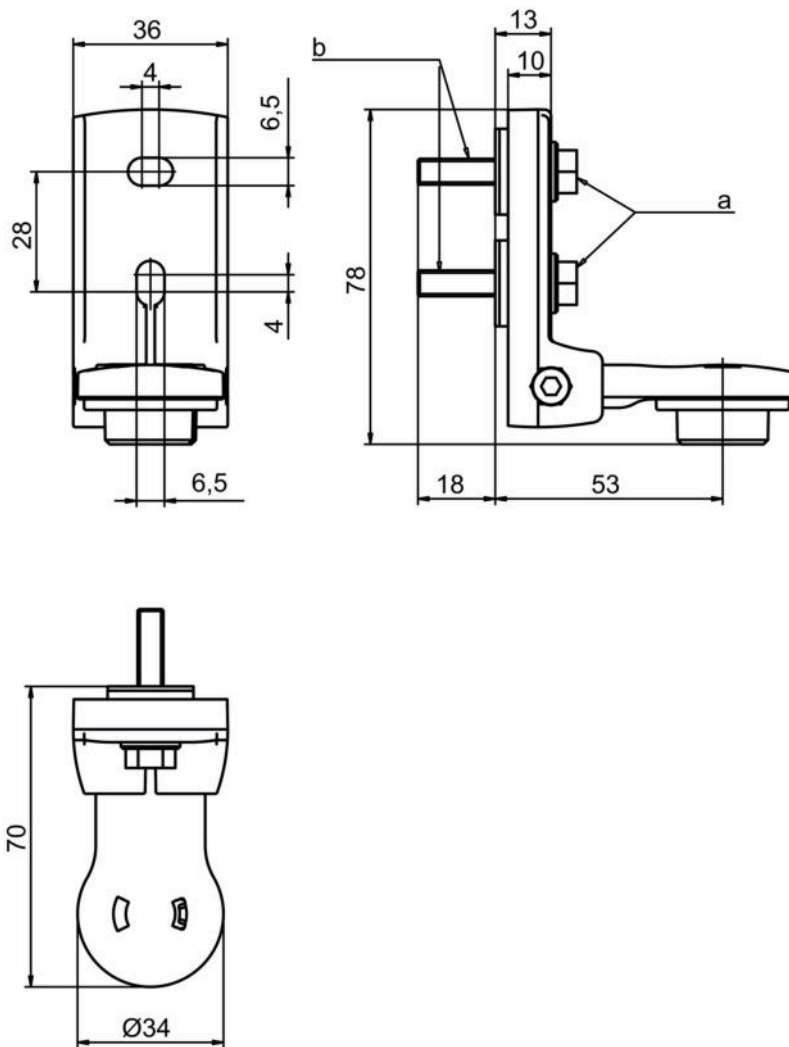

- a M6 screw
- b Shock absorber, M6 thread

BT-SET-240CS swivel mount

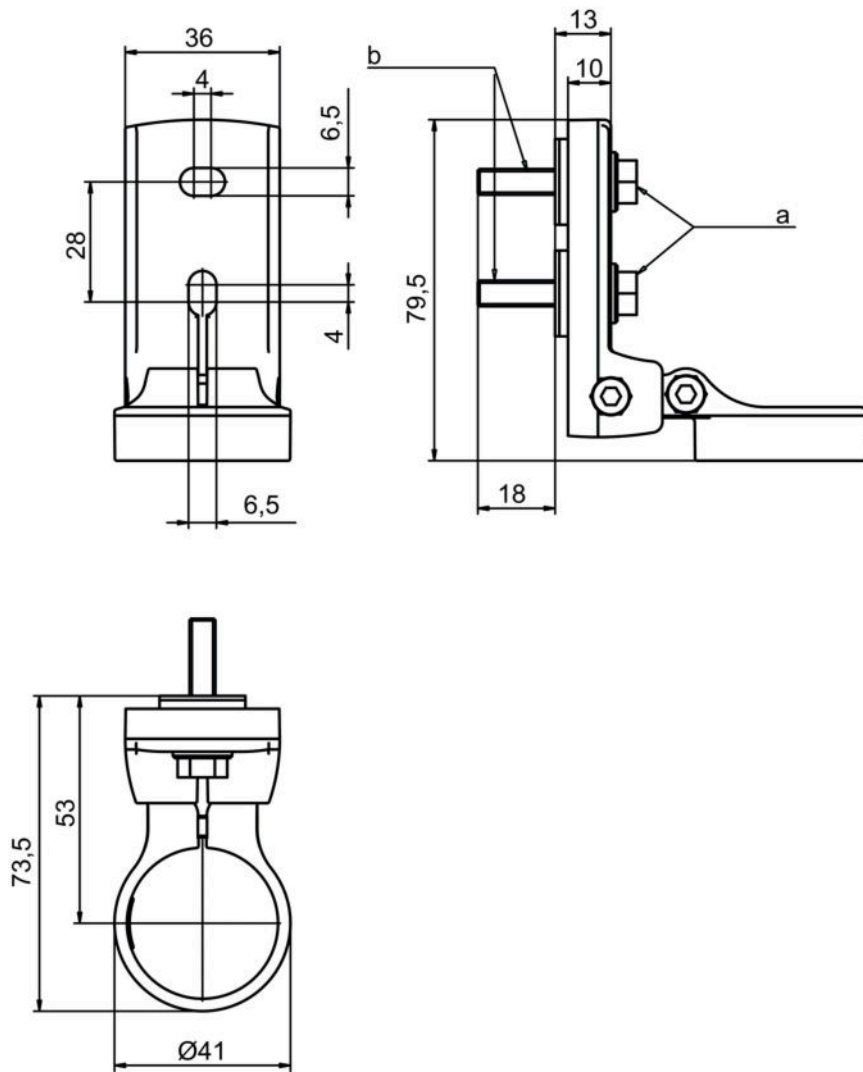

a M6 screw

b Shock absorber, M6 thread

Mounting dimensions

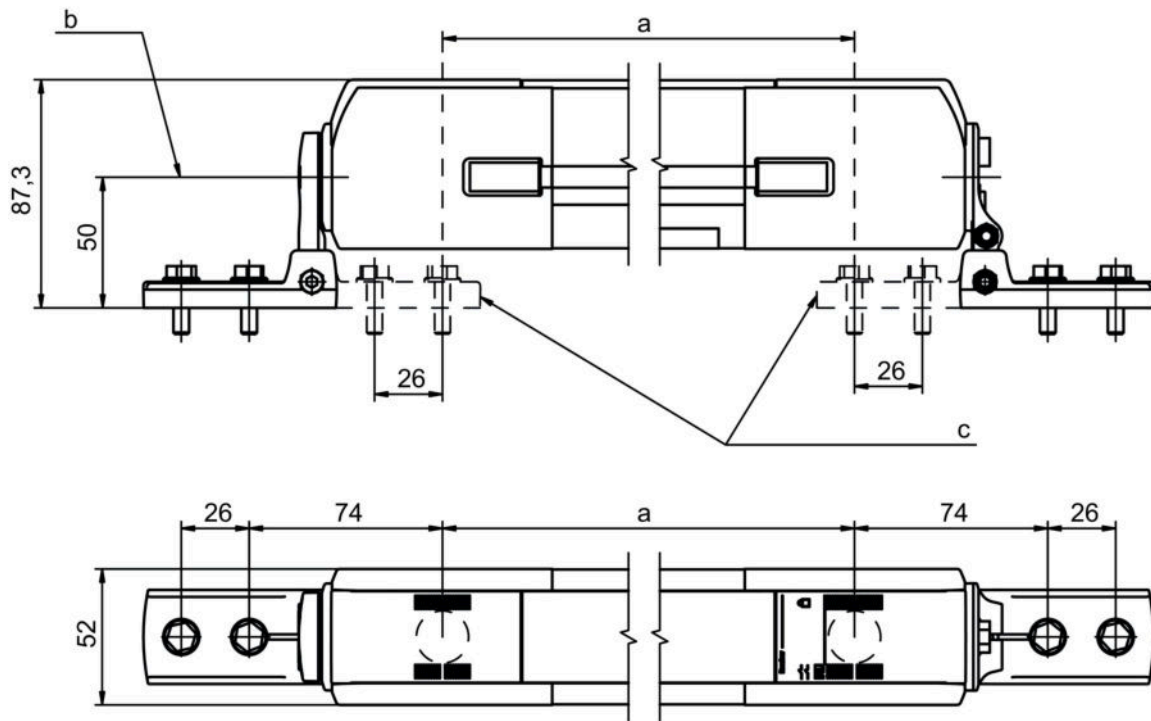

- a Beam spacing
- b Swivel axis
- c Alternative mounting variant

Mounting variants

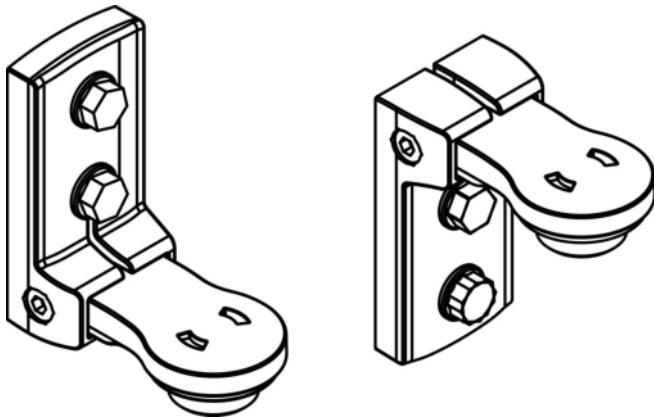

Mounting variants

