

## Specifications:

**Finish:** [Unit of Plating Thickness Is in Micro Inch (μ)]

1. Nickel Plating
2. Tin Plating
3. Gold Plating Thickness: 2 μ" max.

Nut	Brass	Finish 1
Washer	Steel	Finish 1
Housing	PBT	White
Soldering Tail	Copper	Finish 2
Mounting Post	Brass	Finish 2
Inner Contact	P. Bronze	Finish 1/3(P)
Insulator	PE	None
Body	Diecast	Finish 1

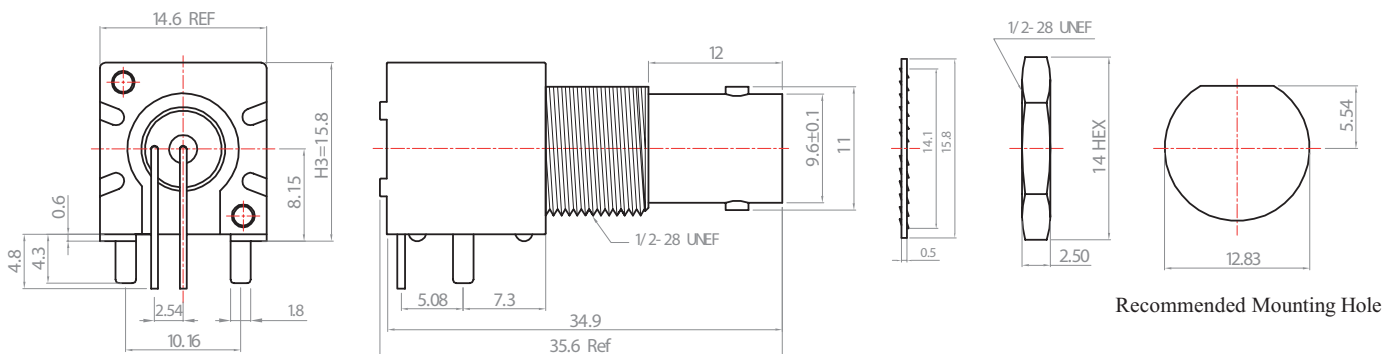
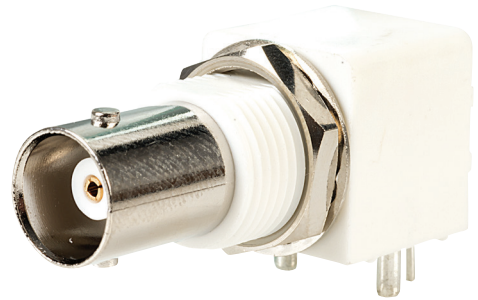

### NOTES:

1. Any Electrical, Mechanical or Environmental Test Per MIL-PRF-39012F Should be Spotlighted, As We May Not Have All Testing Equipment to Cover All of It.
2. All Metal Materials Are in Compliance with RoHS 2 Directive 2011/65/EU Annex III Section 6 Paragraph.

## Electrical:

Impedance : 50 ohm  
 Frequency Range : 0~ 1 GHz .  
 Voltage Rating : ≥500 V rms (depending on cable)  
 Insulator Resistance : ≥5 GΩ  
 Dielectric Withstanding Voltage : 1 500 V rms .  
 Contact Resistance : Center Contact ≤1.5 mΩ.  
 Outer Contact ≤1 mΩ .

## Mechanical:

Mating : Bayonet Coupling.  
 Recommended Mating Torque : 0.6~2.5 lbs  
 Coupling Nut Retention Force : ≥101.2 lbs

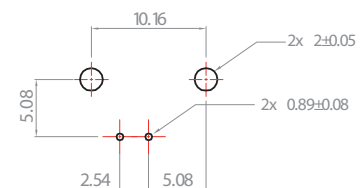

Recommended PCB Layout

## Environmental :

Temperature Range : -65°C to 165°C  
 Corrosion(Salt Spray) : MIL-STD-202, Method 101, Cond. B  
 Thermal Shock : MIL-STD-202, Method 107, Cond. B  
 Mechanical : MIL-STD-202, Method 213, Cond. G  
 Vibration : MIL-STD-202, Method 204, Cond. B