

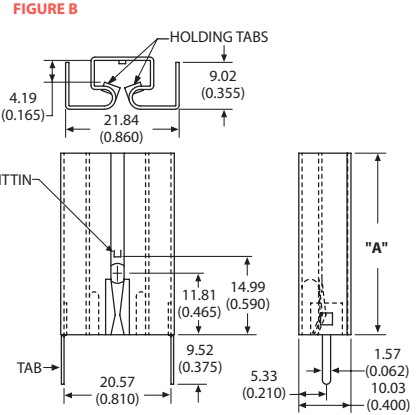

5744, 5745, 5746, 5749 Low cost, labor saving, slide on heat sink featuring spring action

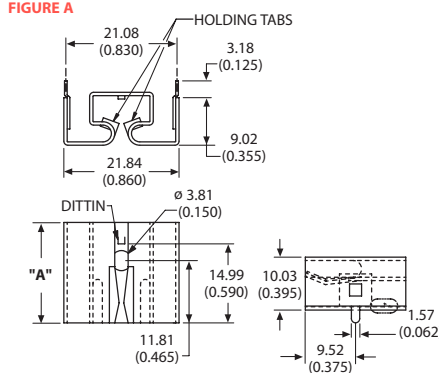

Low cost, labor saving, slide on heat sink features spring action to firmly hold the device tab to the heat sink providing maximum metal to metal contact and good thermal conduction. Available with solderable tabs for horizontal or vertical mounting to the PC board.



Material: 0.63 (0.025) Thick Aluminum
Finish: Black Anodize

ORDERING INFORMATION

Part Number	Description	Figure	"A" Dim	Dia of PCB Plated Thru Hole for Tabs
574402B00000G	Low cost slide on heat sink, no solderable tabs	A	19.05 (0.750)	
574402B03200G	With solderable tabs for horizontal mounting	A	19.05 (0.750)	1.91 (0.075)
574502B00000G	Low cost slide on heat sink, no solderable tabs	B	19.05 (0.750)	
574502B03300G	With solderable tabs for vertical mounting	B	19.05 (0.750)	1.91 (0.075)
574602B00000G	Low cost slide on heat sink, no solderable tabs	B	17.53 (0.690)	
574602B03300G	With solderable tabs for vertical mounting	B	17.53 (0.690)	1.91 (0.075)
574902B00000G	Low cost slide on heat sink, no solderable tabs	B	35.05 (1.380)	
574902B03300G	With solderable tabs for vertical mounting	B	35.05 (1.380)	1.91 (0.075)

For additional options see page 82

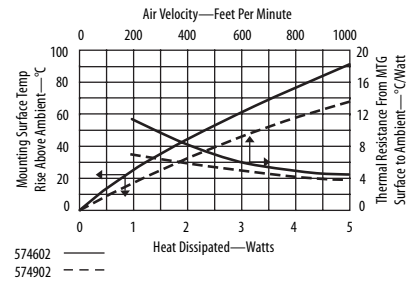
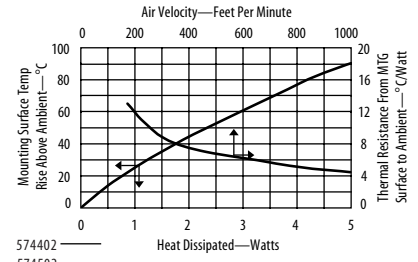

5741 Low cost, labor saving, slide on heat sink featuring spring action



Low cost, labor saving, slide on heat sink features spring action to firmly hold the device tab to the heat sink providing maximum metal to metal contact and good thermal conduction. Includes a clearance hole in the top side to allow the use of optional hardware to attach device and heat sink to circuit board or other surface. Also available with solderable tabs for vertical mounting to the PC board.

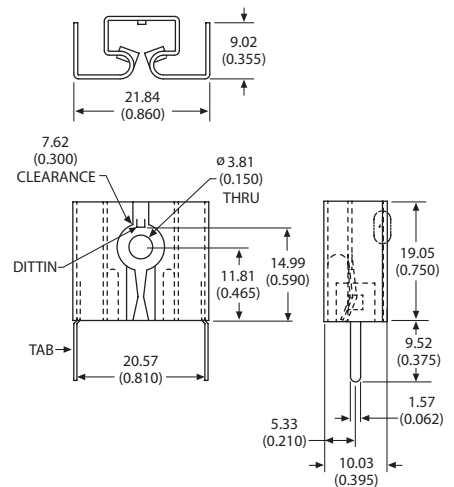
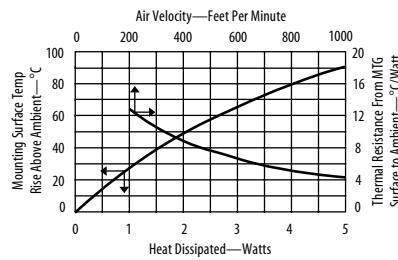

Material: 0.63 (0.025) Thick Aluminum
Finish: Black Anodize

ORDERING INFORMATION

Part Number	Description	Dia of PCB Plated Thru Hole for Tabs
574102B00000G	Low cost slide on heat sink, no solderable tabs	
574102B03300G	With solderable tabs	1.91 (0.075)

POPULAR OPTIONS: 574102B00000G
Base part no. A

Position	Code	Description	Details
A	37	Solderable tab with step to limit insertion depth	Page 92

For additional options see page 82

