

## Protective cover IP55, fixed mounted design

**Part no.** IZMX-DC16-F-1  
**Article no.** 184235  
**Catalog No.** 68D2539G02

### Delivery programme

Product range			Accessories
Accessories			Degree of protection IP55
Accessories			Protective cover
			The front of the circuit-breaker projects through the door cut-out. The protective cover covers the circuit-breaker and the door cut-out and makes it possible to have an IP55 degree of protection. The protective cover can be swung open to the left or right.
For use with			IZMX16...F INX16...F
Information about equipment supplied			The mounting kit includes a protective cover, a hinge, a door seal, and fixing material.
Installation type			Fixed

### Design verification as per IEC/EN 61439

Technical data for design verification			
Operating ambient temperature min.		°C	-25
Operating ambient temperature max.		°C	70

### Technical data ETIM 6.0

Low-voltage industrial components (EG000017) / Accessories for low-voltage switch technology (EC002498)			
Electric engineering, automation, process control engineering / Low-voltage switch technology / Low-voltage switch technology (accessories) / Component for low-voltage switch technology (accessories) (ecl@ss8.1-27-37-92-01 [AKN570010])			
Type of accessory			Cover

## Dimensions

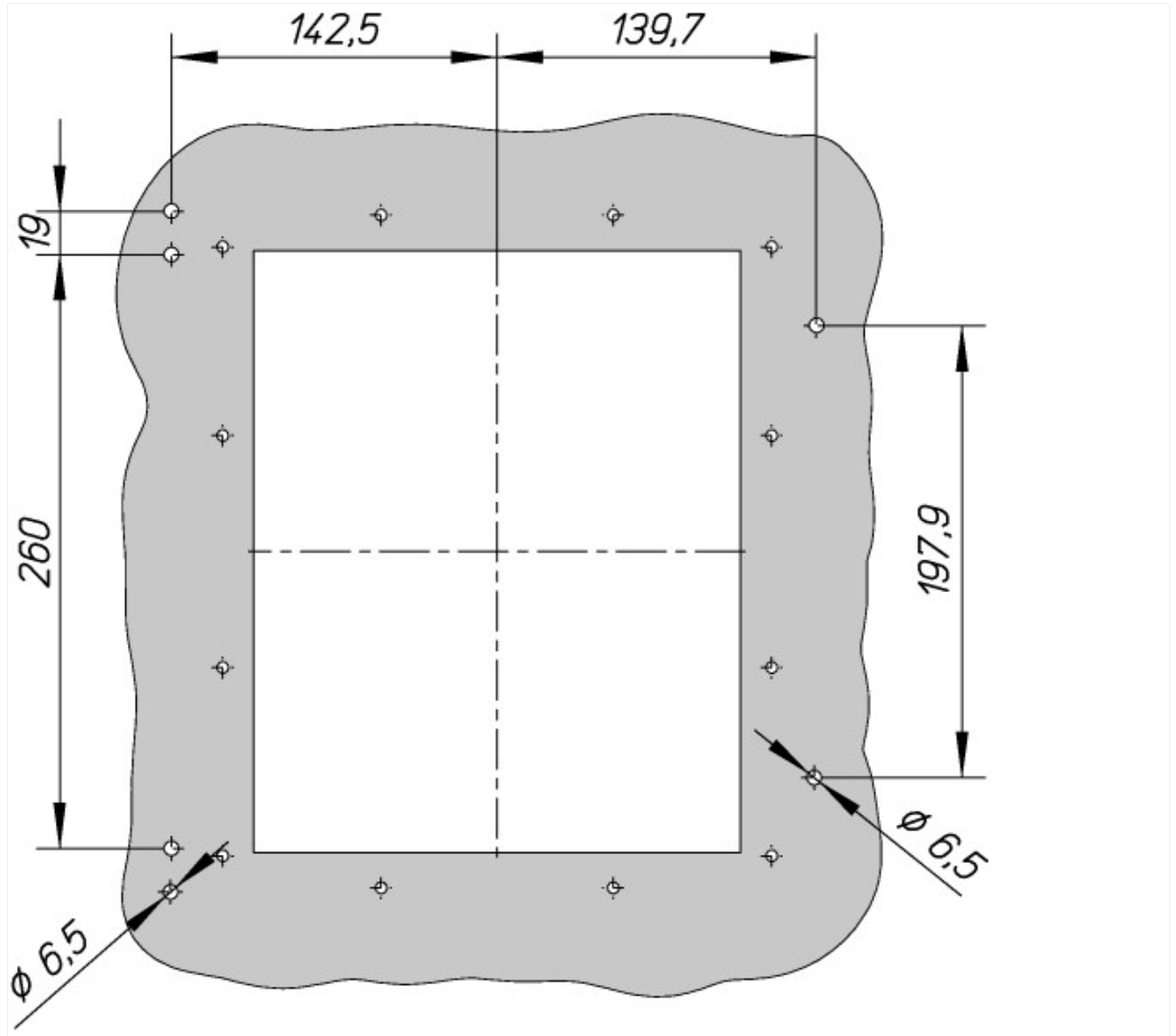

③ Top edge mounting floor of the Circuit Breaker

