

DO NOT SCALE DRAWING

REVISION

A INITIAL DRAWING 28.9.15

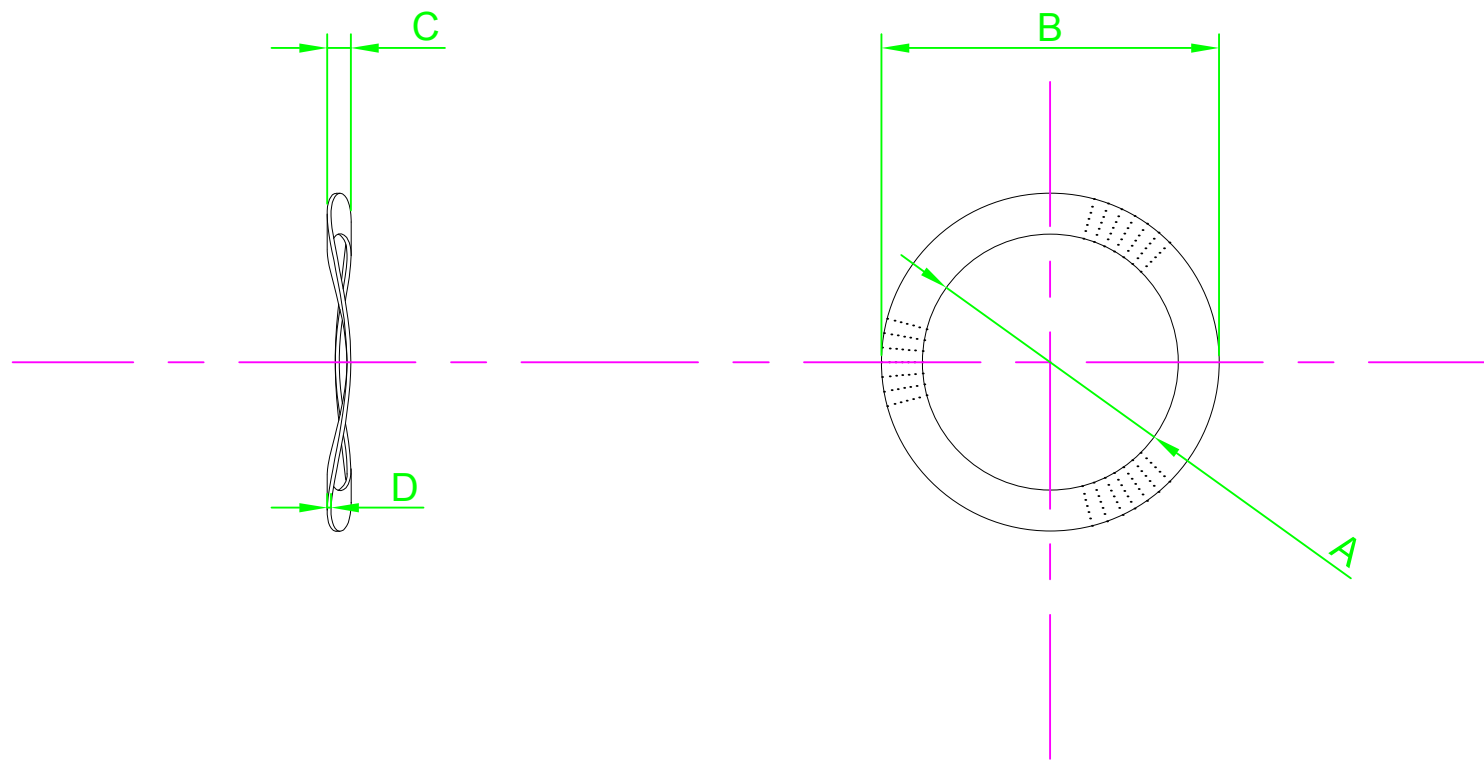

Part Number	A Max	B Max	C Max	D Nom	Pack Size
M2.5 - CWBCWA S100	2.8	5.8	0.53	0.16	100
M3 - CWBCWA S100	3.32	6.4	0.61	0.16	100
M5 - CWBCWA S50	5.42	9.2	0.89	0.30	50
M6 - CWBCWA S50	6.55	11.5	1.14	0.40	50

NOTES:



DESIGN RIGHT. TR FASTENINGS LTD, 2003
 UNDER NO CIRCUMSTANCES MUST THIS
 DRAWING BE COPIED OR DISCLOSED
 WITHOUT FIRST OBTAINING WRITTEN
 AUTHORITY.

UNLESS OTHERWISE SPECIFIED:
 DIMENSIONS ARE IN MM (MILLIMETERS).
 SURFACE FINISH:
 TOLERANCES: BS 4463

	NAME	DATE
DRAWN	Darryl Wilson	28.09.15
CHK'D		
APPVD		

MATERIAL:
 Copper Beryllium

HEAT TREATMENT:
 N/A

FINISH:
 Self Finish

TITLE:
 Crinkle Washer BS 4463

DRAWING NUMBER:
 TR32CWBCWA

A4