

## Flat and copy milling heads

For milling inserts: RCKX, OCKX, XCKX, XOKX, SAHT

**ATORN®**

### Application

With a total of 5 different insert types in different cemented carbide grades, there is a wide range of application possibilities. Minimum-vibration milling is guaranteed with low chipping forces and good chip removal for round, square or octagonal inserts. The low cutting force reduces the drive power required by up to 25%, which facilitates use on less efficient machines without issue.

### Version

- Wear-resistant, nickel-plated version
- With internal cooling
- Clamping screw tightening torque (indexable insert) M5 = 8 Nm

### Advantage

- Versatile with its 5 different insert types
- Low chipping forces
- Minimum-vibration milling
- Low power consumption
- High axial infeed

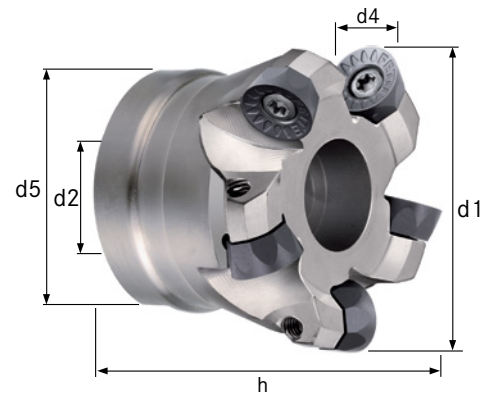

<b>Art. No.</b>	<b>16027 152</b>
<b>Max. cutting edge diameter</b>	52 mm
<b>Length</b>	40 mm
<b>Bore diameter</b>	22 mm
<b>Number of cutting edges</b>	4 PCS

### EAN-Code

4050293538878

