

Product Data Sheet 612 N/37NV

**ebmpapst**

The engineer's choice



612 N/37NV

INDEX

<b>1</b>	<b>General</b> .....	<b>3</b>
<b>2</b>	<b>Mechanics</b> .....	<b>3</b>
2.1	General.....	3
2.2	Connections.....	3
<b>3</b>	<b>Operating Data</b> .....	<b>4</b>
3.1	Electrical Interface - Input.....	4
3.2	Electrical Operating Data .....	5
3.3	Electrical Interface - Output.....	6
3.4	Electrical Features .....	6
3.5	Aerodynamics.....	8
3.6	Sound Data.....	10
<b>4</b>	<b>Environment</b> .....	<b>10</b>
4.1	General.....	10
4.2	Climatic Requirements .....	10
<b>5</b>	<b>Safety</b> .....	<b>11</b>
5.1	Electrical Safety .....	11
5.2	Approval Tests.....	11
<b>6</b>	<b>Reliability</b> .....	<b>11</b>
6.1	General.....	11

## 1 General

Fan type	Fan	
Rotating direction looking at rotor	Clockwise	
Airflow direction	Air outlet over struts	
Bearing system	Ball bearing	
Mounting position - shaft	Any	

## 2 Mechanics

### 2.1 General

Width	60,0 mm	
Height	60,0 mm	
Depth	25,0 mm	
Mass	0,066 kg	
Housing material	Plastic	
Impeller material	Plastic	
Max. torque when mounted across both mounting flanges	Wire outlet corner: 20 Ncm Remaining corners: 40 Ncm	
Screw size	ISO 4762 - M3 degreased, without an additional brace and without washer	

### 2.2 Connections

Electrical connection	Wires	
Lead wire length	L = 310 mm	
Tolerance	+ - 10,0 mm	

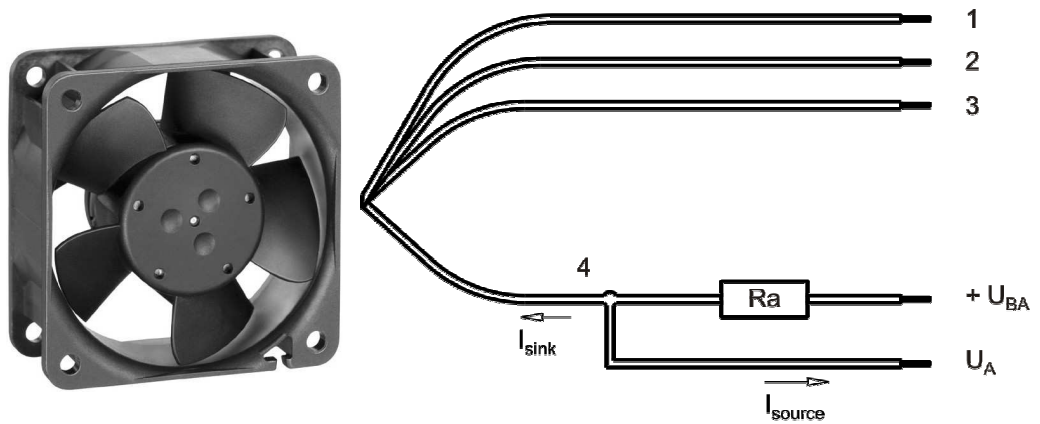

Wire	Color	Operation	Wire size	Insulation diameter
1	red	+ UB	AWG 26	1,35 mm
2	blue	- GND	AWG 26	1,35 mm
3	violet	NTC	AWG 26	1,35 mm
4	white	Alarm		

The auxiliaries shown on the schematic diagram (which are required for the intended use) are not part of our delivery.

3 Operating Data

3.1 Electrical Interface - Input

Control input	External Temperature Sensor
---------------	-----------------------------

Features

<p><b>Characteristics</b></p>	<table border="1"> <caption>Graph Data: Drehzahl / speed [r/min] vs Umgebungstemperatur / Ambient temperature [°C]</caption> <thead> <tr> <th>Umgebungstemperatur / Ambient temperature [°C]</th> <th>Drehzahl / speed [r/min]</th> </tr> </thead> <tbody> <tr><td>-20</td><td>3000</td></tr> <tr><td>-10</td><td>3000</td></tr> <tr><td>0</td><td>3000</td></tr> <tr><td>10</td><td>3000</td></tr> <tr><td>20</td><td>3000</td></tr> <tr><td>30</td><td>3000</td></tr> <tr><td>40</td><td>3800</td></tr> <tr><td>50</td><td>4600</td></tr> <tr><td>60</td><td>5000</td></tr> </tbody> </table>	Umgebungstemperatur / Ambient temperature [°C]	Drehzahl / speed [r/min]	-20	3000	-10	3000	0	3000	10	3000	20	3000	30	3000	40	3800	50	4600	60	5000
Umgebungstemperatur / Ambient temperature [°C]	Drehzahl / speed [r/min]																				
-20	3000																				
-10	3000																				
0	3000																				
10	3000																				
20	3000																				
30	3000																				
40	3800																				
50	4600																				
60	5000																				
<p><b>Schematics</b></p>	<p>The schematic shows the fan's electrical interface. On the left is a fan symbol labeled 'Lüfter / Fan'. On the right is the 'Kunde / Customer' interface. The circuit includes a power supply line '+ UB', an internal reference line '+ Interne Ref. / + Internal ref.', an input terminal 'Eingang / Input', an NTC sensor, and a ground line '- GND'. A resistor is connected between the input terminal and the internal reference line, and another resistor is connected between the input terminal and the NTC sensor. The NTC sensor is connected to the ground line.</p>																				

### 3.2 Electrical Operating Data

Measurement conditions: Normal air density = 1,2 kg/m<sup>3</sup>; Temperature 23°C +/- 3°C; Motor axis horizontal; warm-up time before measuring 5 minutes (unless otherwise specified). In the intake and outlet area should not be any solid obstruction within 0,5 m.

$\Delta p = 0$ : corresp. to free air flow (see chapter aerodynamics)

I: corresp. to arithm. mean current value

Name	Condition		
TU 0001	TU: $\geq 55$ °C		
NTC 0001	NTC < 28 kOhm		

Features	Condition	Symbol	Values		
Voltage range		U	8 V		12,6 V
Nominal voltage		$U_N$		12,0 V	
Power consumption	$\Delta p = 0$	P	0,7 W	2,4 W	1,6 W
Tolerance	TU / NTC 0010		+/- 20 %	+/- 20,0 %	+/- 20,0 %
Current consumption	$\Delta p = 0$	I	80 mA	200 mA	130 mA
Tolerance	TU / NTC 0010		+/- 20,0 %	+/- 20,0 %	+/- 20,0 %
Speed	$\Delta p = 0$	n	2.900 1/min	5.100 1/min	5.100 1/min
Tolerance	TU / NTC 0010		+/- 10,0 %	+/- 10,0 %	+/- 10,0 %
Starting current consumption				940 mA	

### 3.3 Electrical Interface - Output

Alarm type	/37 (high = ok, open collector inverse)
------------	---

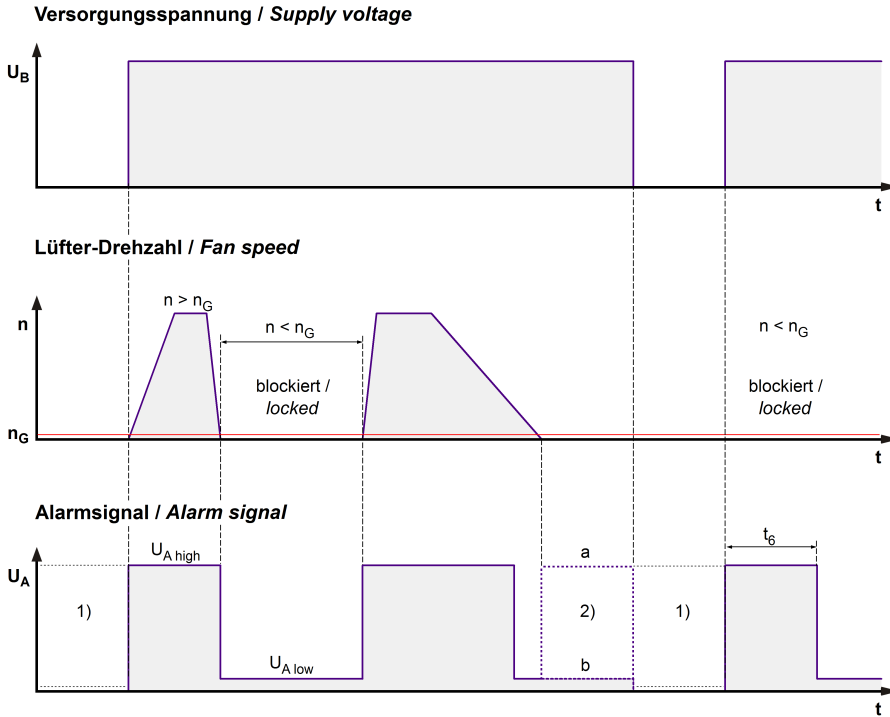

$$R_a = \frac{U_{BA} - U_{A\text{low}}}{I_{\text{sink}}}$$

Lüfter / Fan      Kunde / Customer

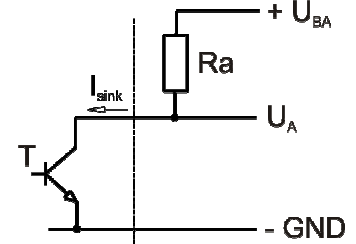

- 1) Wenn der Lüfter abgeschaltet ist, hängt der Zustand des Ausgangssignals  $U_A$  von der Kundenapplikation ab.  
 When the fan is powered off, the output signal  $U_A$  depends on the customer's application.
- 2) Für den gültigen Zustand (a oder b) siehe Alarmunterdrückung in der Tabelle.  
 For the valid condition (a or b) see alarm suppression in the table.

Features	Note	Values
Alarm operating voltage	$U_{BA}$	$\leq 30\text{ V}$
Alarm signal Low	$U_{A\text{low}}$	$\leq 0,4\text{ V}$
Alarm signal High	$U_{A\text{high}}$	$30\text{ V}$
Maximum sink current	$I_{\text{sink}}$	$10\text{ mA}$
External resistor	External resistor $R_a$ from $U_{BA}$ to $U_A$ required. All voltage measured to GND.	
Alarm trip speed limit	$n_G$	$0\text{ 1/min}$
Alarm at sense failure	No	
Alarm latch	No	
Alarm isolated from motor	No	

### 3.4 Electrical Features

Electronic function	None	
Reversed polarity protection	Rectifying diode	
Max. residual current at $U_N$	$I_F \leq 50\text{ }\mu\text{A}$	
Locked rotor protection	Auto restart	
Locked rotor current at $U_N$	$I_{\text{block}}$ approx. $940\text{ mA}$	
Clock signal at locked rotor	$t_3 / t_4$ typical: $0,23\text{ s} / 1,1\text{ s}$	

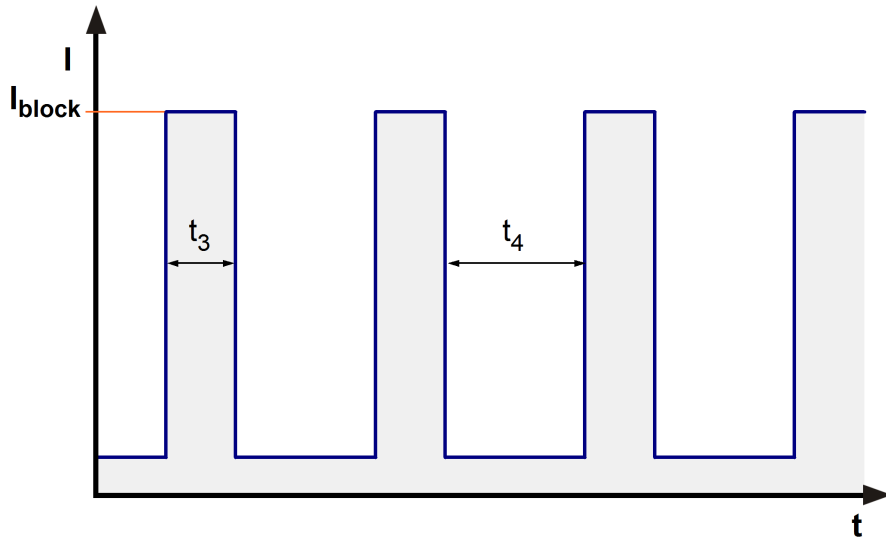

### 3.5 Aerodynamics

Measurement conditions: Measured with a double chamber intake rig acc. to DIN EN ISO 5801.  
 Normal air density = 1,2 kg/m<sup>3</sup>; Temperature 23°C +/- 3°C;  
 In the intake and outlet area should not be any solid obstruction within 0,5 m. Motor shaft horizontal.  
 The information is only valid under the specified test conditions and may be changed by the installation conditions. If there are deviations from the standard test conditions, the characteristic values must be checked under the installed conditions.

a.) Operation condition:

5.100 1/min at free air flow	TU >= 55 °C NTC < 28 kOhm		
Max. free-air flow ( $\Delta p = 0 / \dot{V} = \text{max.}$ )		40,0 m <sup>3</sup> /h	
Max. static pressure ( $\Delta p = \text{max.} / \dot{V} = 0$ )		76 Pa	



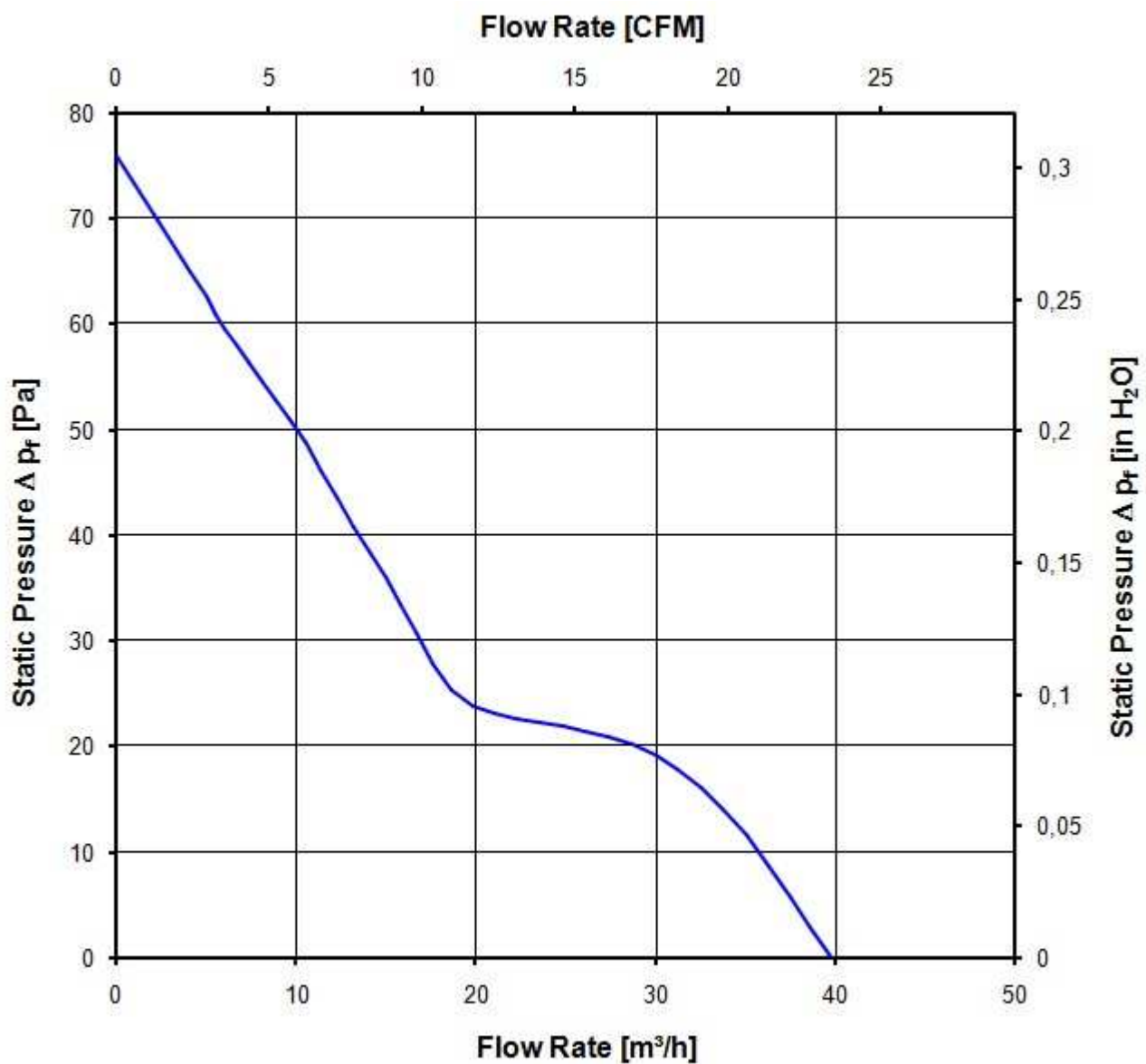

**3.6 Sound Data**

Measurement conditions: Sound pressure level: 1 meter distance between microphone and the air intake.  
 Sound power level: Acc. to DIN 45635 part 38 (ISO 10302)  
 Measured in a semianchoic chamber with a background noise level of  $L_p(A) < 5 \text{ dB(A)}$   
 For further measurement conditions see chapter aerodynamics.

a.) Operation condition:

5.100 1/min at free air flow	TU $\geq 55 \text{ }^\circ\text{C}$ NTC $< 28 \text{ k}\Omega$		
------------------------------	---	--	--

Optimal operating point	31,0 m <sup>3</sup> /h @ 17 Pa	
Sound power level at the optimal operating point	5,0 bel(A)	
Sound pressure level at free air flow, measured in rubber bands	35,0 dB(A)	

**4 Environment**

**4.1 General**

Min. permitted ambient temperature TU min.	-20 $^\circ\text{C}$	
Max. permitted ambient temperature TU max.	65 $^\circ\text{C}$	
Min. permitted storage temperature TL min.	-40 $^\circ\text{C}$	
Max. permitted storage temperature TL max.	80 $^\circ\text{C}$	

**4.2 Climatic Requirements**

Humidity requirements	humid heat, constant; according to DIN EN 60068-2-78, 14 days	
Water exposure	None	
Dust requirements	None	
Salt fog requirements	None	

Permitted application area:

The product is intended for use in sheltered rooms with controlled temperature and controlled humidity. Directly exposure to water must be avoided.

Pollution degree 1 (according DIN EN 60664-1)

There is either no pollution or it occurs only dry, non-conductive pollution. The pollution has no negative impact.

Please require severity levels and specification parameters from the responsible development departments.

**5 Safety**

**5.1 Electrical Safety**

Dielectric strength DIN EN 60950 (VDE 0805) and DIN EN 60335 (VDE 0700) A.) Type test Measuring conditions: After 48h of storage at 95% R.H. and 25°C. No arcing or breakdown is allowed! All connections together to ground.	Not applicable	
B.) Routine test Measuring conditions: At indoor climate. No arcing or breakdown is allowed! All connections together to ground.	Not applicable	
Isolation resistance Measuring conditions: After 48h of storage at 95% R.H. and 25°C measured with U=500 VDC for 1 min.	RI > 10 MOhm	
Clearance / creepage distance	1,0 mm / 1,2 mm	
Protection class	III	

**5.2 Approval Tests**

CE	EC Declaration of Conformity	Yes
EAC	Eurasian Conformity	Yes
UL	Underwriters Laboratories	Yes / UL507, Electric Fans
VDE	Association for Electrical, Electronic and Information Technologies	Yes / Approval acc. to EN 60950 (VDE 0805) - Information technology equipment
CSA	Canadian Standards Association	Yes / C22.2 No. 113 Fans and Ventilators
CCC	China Compulsory Certification	Not applicable

**6 Reliability**

**6.1 General**

Life expectancy L10 at TU = 40 °C	70.000 h	
Life expectancy L10 at TU = 60 °C	44.000 h	
Life expectancy L10 at TU max.	40.000 h	
Life expectancy L10 acc. to IPC 9591 at TU = 40 °C	117. 500 h	

Copying of this document, and giving it to others and the use or communication of the contents thereof, are forbidden without express authority. Offenders are liable to the payment of damages. All rights are reserved in the event of the grant of a patent or the registration of a utility model or design.

Schutzvermerk nach DIN ISO 16016 beachten/  
 Refer to protection notice DIN ISO 16016!

Anzahl und Länge der Litze s. Spezifikation  
 length and number of wires see design specification

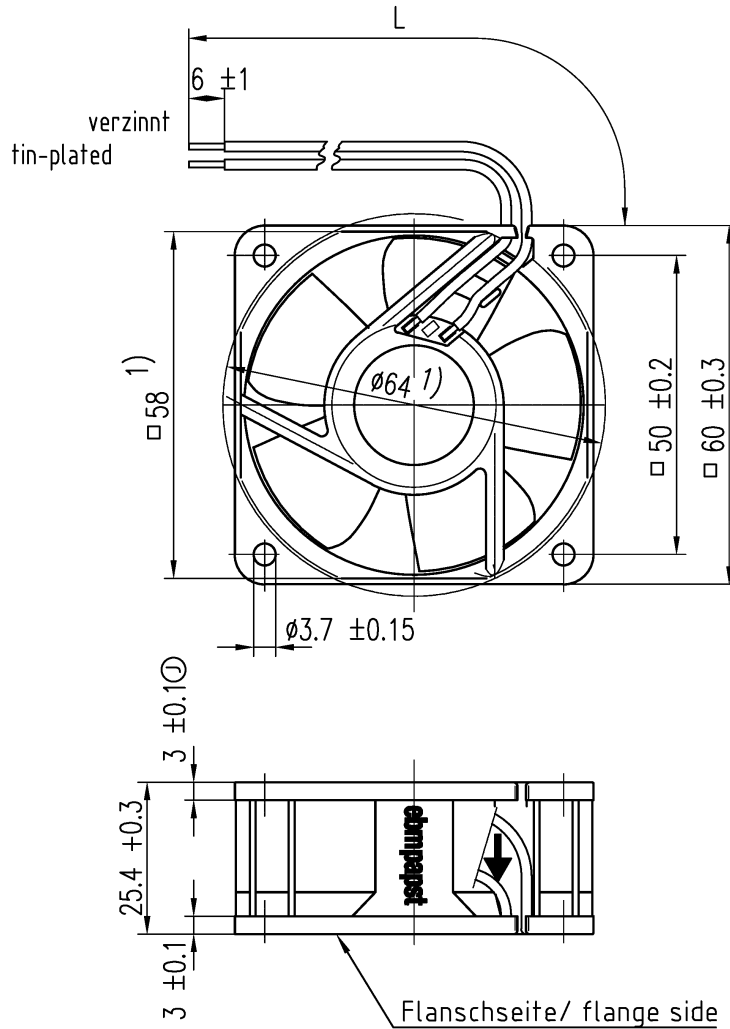

1) Maße für Montagewand  
 1) dimensions for assembly wall

		ebmpapst		Werkstoff/Material:		Volumen/Volume (mm <sup>3</sup> ):	
SAP-Status/State	Änd.-Nr./Change-No.	AutoCAD-System-Version	CAD-Umgebung/ CAD-Environment			Gewicht/Mass (g):	
		Datum/Date		Name/Name		Artikel/Title	
		Bearb./ Drawn					
Tolerierung/Tolerances:		Gepr./ Checked					
Allgemeintoleranzen/Gen. tolerances:		Freig./ Released					
		<b>ebmpapst</b>		Zchg.-Nr./ Drawing.-No.:		Ers.f.Zchg./ Replaces:	
		ebm-papst St. Georgen GmbH & Co. KG		Dokumenttyp/Type of Document	Teildokument (Blatt/Page)	Index/Index	Format/Size:    Massstab/scale