

2D/3D Profile Sensor

MLWL221

LASER

weCat3D

Part Number



- Optimized profile quality thanks to HDR function
- Precise measuring range resolution X (> 2000 measuring points)
- Up to 12 million measuring points per second

2D/3D Profile Sensors project a laser line onto the object to be detected and generate an accurate, linearized height profile with an internal camera which is set up at a triangulation angle. Thanks to its uniform, open interface, the weCat3D series can be incorporated by means of the DLL program library or the GigE Vision standard without an additional control unit. Alternatively, wenglor offers its own software packages for implementing your application.

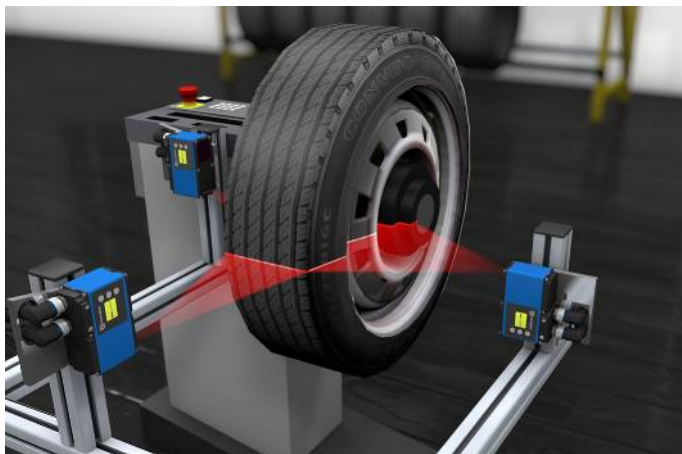

Technical Data

Optical Data	
Working range Z	120...300 mm
Measuring range Z	180 mm
Measuring range X	65...145 mm
Linearity Deviation	45 µm
Resolution Z	5,2...26 µm
Resolution X	36...81 µm
Light Source	Laser (red)
Wavelength	660 nm
Laser Class (EN 60825-1)	2M
Max. Ambient Light	5000 Lux
Electrical Data	
Supply Voltage	18...30 V DC
Current Consumption (U _b = 24 V)	300 mA
Measuring Rate	175...6000 /s
Subsampling	350...6000 /s
Temperature Range	0...45 °C
Storage temperature	-20...70 °C
Inputs/Outputs	4
Switching Output Voltage Drop	< 1,5 V
Switching Output/Switching Current	100 mA
Short Circuit Protection	yes
Reverse Polarity Protection	yes
Overload Protection	yes
Interface	Ethernet TCP/IP
Baud Rate	100/1000 Mbit/s
Protection Class	III
FDA Accession Number	1710274-000
Mechanical Data	
Housing Material	Aluminum
Degree of Protection	IP67
Connection	M12 × 1; 12-pin
Type of Connection Ethernet	M12 × 1; 8-pin, X-cod.
Optic Cover	Glass
Weight	580 g
Web server	yes

Configurable as PNP/NPN/Push-Pull	<input checked="" type="checkbox"/>
Switchable to NC/NO	<input checked="" type="checkbox"/>
Connection Diagram No.	1022 1034
Control Panel No.	X2 A22
Suitable Connection Equipment No.	50 87
Suitable Mounting Technology No.	343

Display brightness may decrease with age. This does not result in any impairment of the sensor function.

Complementary Products

Control Unit	
Cooling Unit ZLWK004	
Protective Screen Retainer ZLWS004	
Software	
Switch EHSS001	

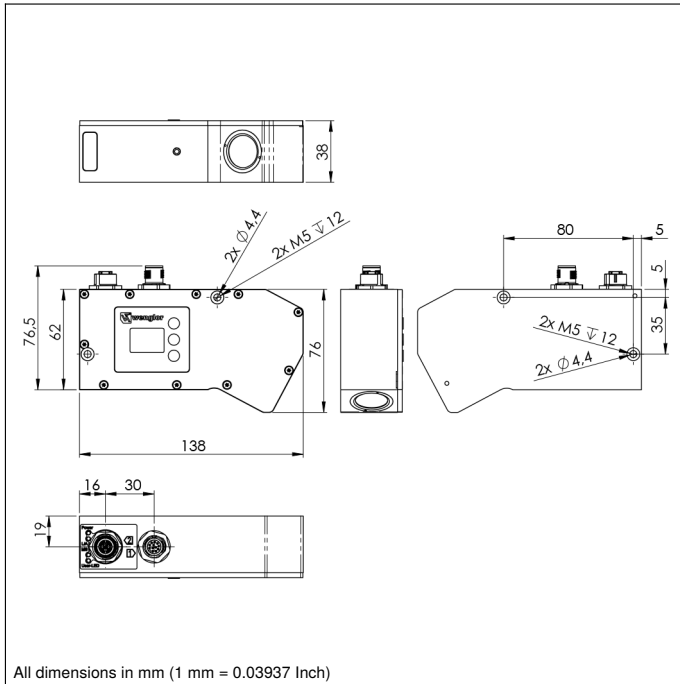

Ctrl. Panel

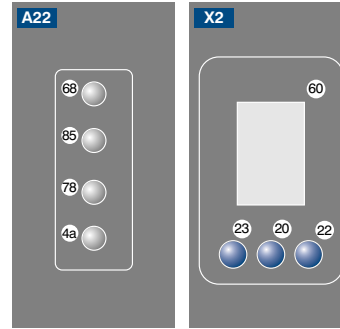

- 20 = Enter Button
- 22 = UP Button
- 23 = Down Button
- 4a = User LED
- 60 = Display
- 68 = Supply Voltage Indicator
- 78 = Module status
- 85 = Link/Act LED

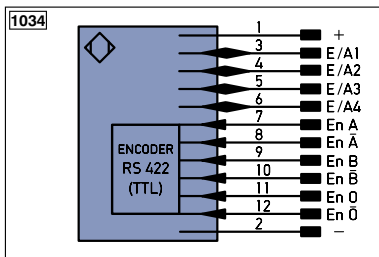
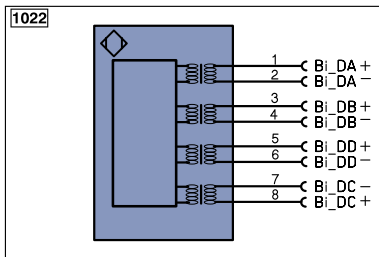

Legend

+	Supply Voltage +	PT	Platinum measuring resistor	EN ^A RS422	Encoder A/ \bar{A} (TTL)
-	Supply Voltage 0 V	nc	not connected	EN ^B RS422	Encoder B/ \bar{B} (TTL)
~	Supply Voltage (AC Voltage)	U	Test Input	EN _A	Encoder A
A	Switching Output (NO)	\bar{U}	Test Input inverted	EN _B	Encoder B
\bar{A}	Switching Output (NC)	W	Trigger Input	A _{MIN}	Digital output MIN
V	Contamination/Error Output (NO)	W-	Ground for the Trigger Input	A _{MAX}	Digital output MAX
\bar{V}	Contamination/Error Output (NC)	O	Analog Output	A _{OK}	Digital output OK
E	Input (analog or digital)	O-	Ground for the Analog Output	SY _{In}	Synchronization In
T	Teach Input	BZ	Block Discharge	SY _{OUT}	Synchronization OUT
Z	Time Delay (activation)	AWV	Valve Output	OL _T	Brightness output
S	Shielding	a	Valve Control Output +	M	Maintenance reserved
RxD	Interface Receive Path	b	Valve Control Output 0 V	rsv	reserved
TxD	Interface Send Path	SY	Synchronization	Wire Colors according to IEC 60757	
RDY	Ready	SY-	Ground for the Synchronization	BK	Black
GND	Ground	E+	Receiver-Line	BN	Brown
CL	Clock	S+	Emitter-Line	RD	Red
E/A	Output/Input programmable	\pm	Grounding	OG	Orange
	IO-Link	S _n R	Switching Distance Reduction	YE	Yellow
PoE	Power over Ethernet	Rx+/-	Ethernet Receive Path	GN	Green
IN	Safety Input	Tx+/-	Ethernet Send Path	BU	Blue
OSSD	Safety Output	Bus	Interfaces-Bus A(+)/B(-)	VT	Violet
Signal	Signal Output	L _a	Emitted Light disengageable	GY	Grey
Bi_D+/-	Ethernet Gigabit bidirect. data line (A-D)	Mag	Magnet activation	WH	White
EN ⁰ RS422	Encoder 0-pulse 0-0 (TTL)	RES	Input confirmation	PK	Pink
		EDM	Contactur Monitoring	GNYE	Green/Yellow

Measuring field X, Z

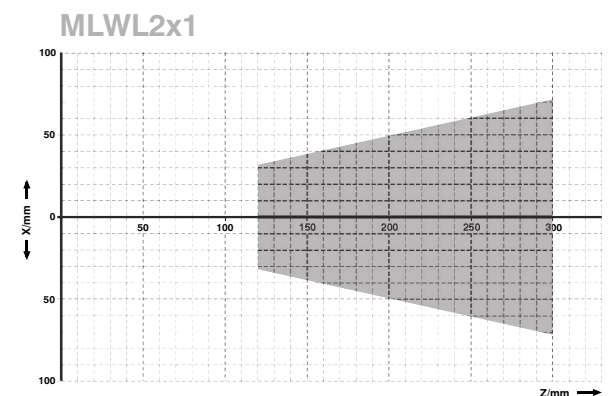

Z = Working distance
 X = Measuring Range

