

## Elastic Couplings DXA

**Material:** Up to size 28: Hubs made from Aluminium.  
From size 32: Hubs made from grey cast iron GG25.  
Insert made from Polyurethane, shore hardness 92° A, white.

- Insertable elastic coupling, for high torques.
- Not backlash-free. Does not transfer any axial forces.
- Robust component for relatively large shaft offset.  
Particularly suitable for large radial offset.

Improved version. Special tooth profile and machined claws result in longer lifetime.

Temperature range: -20°C to +80°C.

**Couplings are available pre-drilled ex stock.**  
**Customized bores and feather-key grooves available at extra charge.**

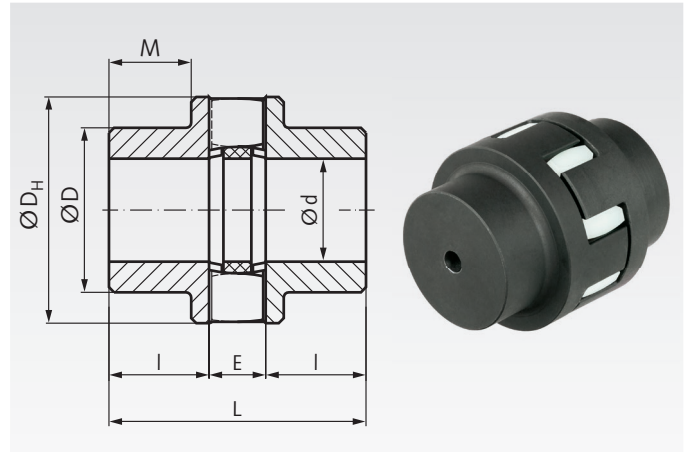

Ordering Details: e.g.: Product No. 60402401, Coupling DXA size 24

Product No.	Size	Torque			Bores			D <sub>H</sub> mm	D mm	L mm	I mm	M mm	E <sup>1)</sup> mm	Max. Shaft Misalignment <sup>2)</sup>			Speed max. min <sup>-1</sup>	Weight max. kg
		nominal Nm	max. Nm	alternating Nm	pre-bored mm	d <sub>max.</sub> mm	radial mm							axial mm	angular °			
604 024 01	24*	80	160	25	-	24	55	55	66	24	-	18	0,3	1,2	0,7	12500	0,55	
604 028 01	28*	120	240	37	-	28	62	62	76	28	-	20	0,3	1,2	0,7	11100	0,76	
604 032 01	32	170	340	51	9	32	70	52	86	32	22	22	0,3	1,2	0,7	9800	1,09	
604 038 01	38	325	650	100	14	38	84	60	100	38	27	24	0,4	1,5	0,7	8100	1,76	
604 042 01	42	460	920	140	14	42	92	68	110	42	31	26	0,4	1,5	0,7	7400	2,38	
604 048 01	48	650	1300	200	17	48	105	76	124	48	36	28	0,4	1,5	0,7	6500	3,38	
604 055 01	55	880	1760	270	17	55	120	88	140	55	43	30	0,5	1,8	0,7	5700	4,89	
604 060 01	60	1150	2300	350	22	60	130	96	152	60	47	32	0,5	1,8	0,7	5200	6,29	
604 065 01	65	1600	3200	480	24	65	142	104	165	65	51	35	0,5	1,8	0,7	4800	8,15	
604 075 01	75	2450	4900	750	30	75	165	120	190	75	59	40	0,6	2,1	0,7	4100	12,6	
604 085 01	85	3350	6700	1000	40	85	185	136	214	85	68	44	0,7	2,1	0,7	3700	17,9	
604 100 01	100	5500	11000	1700	58	100	220	160	250	100	80	50	0,8	2,4	0,7	3100	29,3	

\* Up to size 28: hubs from aluminium.

<sup>1)</sup> At mounting, the distance between the hubs must be measure E to allow the max. shaft misalignment.

<sup>2)</sup> The displacement values stated in the tables are maximum values, which must not occur at the same time at the maximum value. If radial and angular displacements do occur simultaneously, the permissible displacement values may only be used proportionately. Furthermore, the figures stated are only valid up to a speed of 600 min<sup>-1</sup>. At higher speeds the misalignment values must again be reduced.

## Spare Part - Spiders for Couplings DX and DXA

**Material:** Polyurethane, Shore hardness 92°A (soft), color white.

Only suitable for couplings DX and DXA.

Temperature range: -20°C to +80°C.

Product No.	Size	Outside Ø		Weight g
		D mm	No. of teeth	
604 124 00	24	53	8	10
604 128 00	28	60	8	14
604 132 00	32	68	8	20
604 138 00	38	80	10	30
604 142 00	42	90	10	40
604 148 00	48	102	10	54
604 155 00	55	117	10	80
604 160 00	60	127	10	92
604 165 00	65	140	10	120
604 175 00	75	162	10	200
604 185 00	85	182	10	260
604 200 00	100	216	10	450

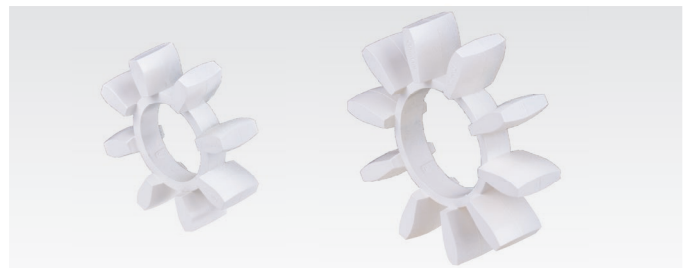

## Advantages of coupling DXA

Common elastic spider couplings have symmetric tooth curves. This leads to an unequal load inside the spider's teeth and means high stress to the top of the teeth, resulting into high wear and requiring a big coupling size. The special, asymmetric tooth profile of couplings DXA ensures a uniform force distribution over the whole tooth. Furthermore, this avoids the moving of the spider's teeth to the middle of the coupling under high load. Contrary to the old version DX, the claws and all other surfaces of coupling DXA are well machined to a fine surface finish. Both, tooth profile and claw finish, enable a higher torque and reduced wear in comparison to common couplings.

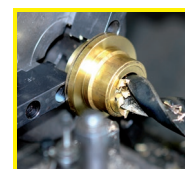

**Reworking within  
24h-service possible.  
Custom made parts  
on request.**