

SYSTEM CONFIDENTIAL

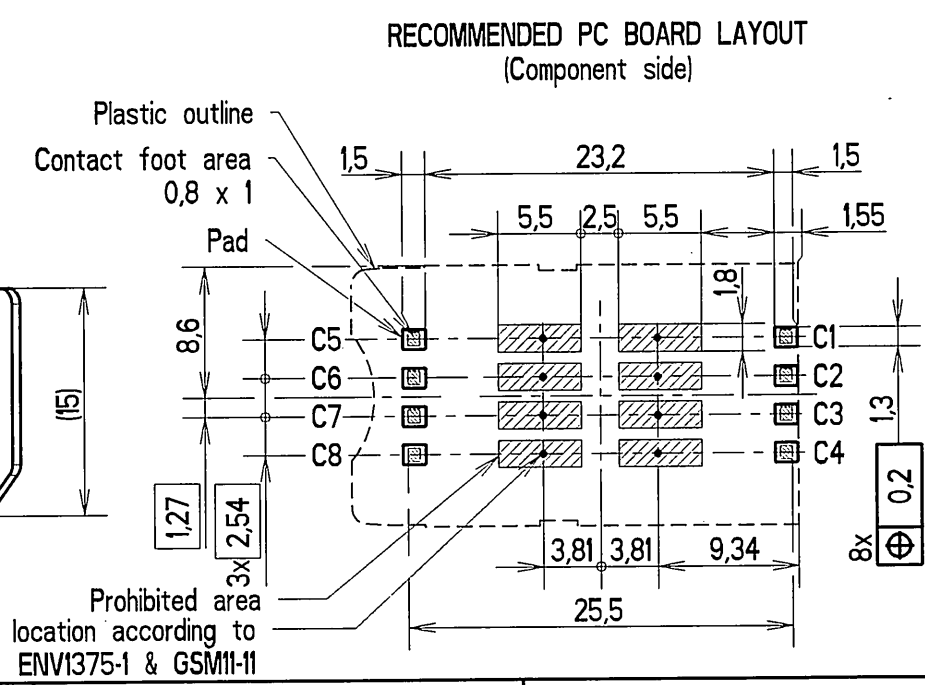
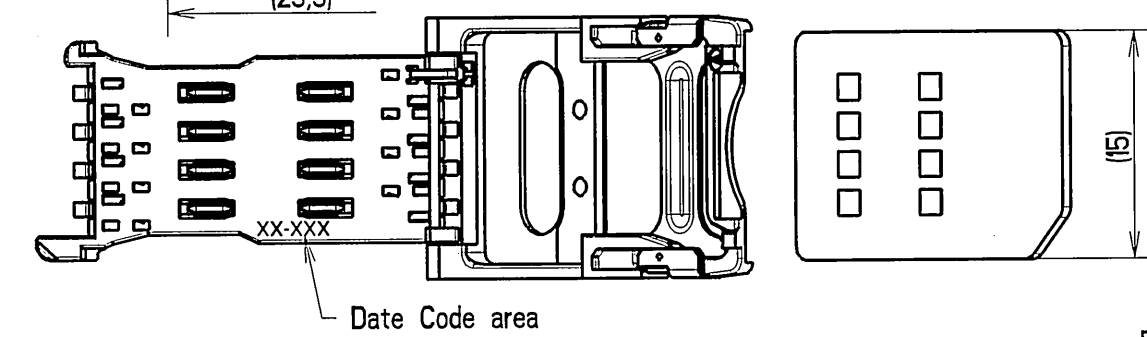

- Notes :
- 1 - Termination to PCB : SMT reflow soldering. Temperature/time profile according to ITT Industries PS-LF-001 specification.
  - 2 - Level of each contact tail compared to the surrounding base of the insulator. Coplanarity of metal soldering surfaces : 0,1 mm.
  - 3 - 2,5 microns min tin on terminal areas.
  - 4 - Contact forces :
    - max 0,5 N per contact with max. card thickness.
    - min 0,2 N per contact with min. card thickness.

- 5 - Precious metal inlay on signal contacts.
- 6 - Operating temperature : -40° C +85° C.
- 7 - Locking force : 4 N ±2N.
- 8 - Retention force of the metal lock on the plastic cover : 20 N min.
- 9 - Cover is replaceable.
- 10 - For packaging on tape and reel, see documents :
  - cu 030276Y0026 : for standard orientation.
  - cu 030276Y0027 : for reversed orientation.

MATIERE	TRAITEMENT			PROTECTION	
SAUF INDIQUE :	TOL LINEAIRE	± 0,1	TOL ANGULAIRE	± 1	DIMENSIONS CRITIQUES ▼
-COTES DONNEES AVANT PROTECTION	ETAT DE SURFACE			Ra	DIMENSIONS SPC ▼
-BAVURES ET ARETES VIVES SUPPRIMEES				ll	
DESSINE	P.DAUBIGNEY	DATE	23-09-05	ANALYSE	N TAB. FAM. Y PRO/E Y LANGAGE E
VERIFIE	G.PINON	DATE	23-09-05		
APPROUVE	L.KUBAT	DATE	23-09-05	REPLACE	
<b>Cannon</b> 		PROJECTION 1-ER DIEDRE		DESIGNATION	
		ECHELLE	2,000	CCM03-3003LFT 2x4 contacts	
BP 359 - 39105 Dole - FRANCE -		TAILLE	FEUILLE	NUMERO	REV
		A3	1 / 1	CU	030288Y3003

CE PLAN EST LA PROPRIETE DE ITT C & I ET NE PEUT ETRE REPRODUIT OU COMMUNIQUE SANS SON AUTORISATION