



TWIST LEVER FOR POSITION SWITCH 3SE51 /52  
 METAL LEVER 30MM LONG WITH PLASTIC ROLLER  
 30MM, CAN BE MOUNTED INVERSELY (TURNED BY  
 180 DEGREES, REAR OF LEVER)

Figure similar

Product designation		actuator for part-turn actuator
Manufacturer article number		
<ul style="list-style-type: none"> <li>of the supplied operating lever</li> </ul>		<a href="#">3SE5000-0AA26</a>

General technical data:

Product function		
<ul style="list-style-type: none"> <li>positive opening</li> </ul>		Yes
Shock resistance		30g / 11 ms
Vibration resistance		0.35 mm / 5g
Mechanical service life (switching cycles)		
<ul style="list-style-type: none"> <li>typical</li> </ul>		15 000 000
Equipment marking		
<ul style="list-style-type: none"> <li>acc. to DIN EN 61346-2</li> <li>acc. to DIN EN 81346-2</li> </ul>		T T
Active principle		mechanical
Explosion protection category for dust		none
Explosion protection category for gas		none

Enclosure:

Coating of the enclosure		Other types
--------------------------	--	-------------

Drive Head:

Design of the operating mechanism		Metal lever, 30 mm long, straight, plastic roller 30 mm
Standard-compliant actuator head		EN 50041, design A
Shape of the switch head		roller
Outer diameter of the switch head	mm	30

### Communication/ Protocol:

**Design of the interface** without

### Ambient conditions:

**Ambient temperature**



- during operation °C -25 ... +85
- during storage °C -40 ... +90

### Installation/ mounting/ dimensions:

**mounting position** any

**Mounting type** screw fixing

### Certificates/ approvals:

General Product Approval	Declaration of Conformity	Test Certificates	other
 CSA	 UL		 EG-Konf.
		<a href="#">Special Test Certificate</a>	<a href="#">Confirmation</a>

### Further information

**Information- and Downloadcenter (Catalogs, Brochures,...)**

<http://www.siemens.com/industrial-controls/catalogs>

**Industry Mall (Online ordering system)**

<http://www.siemens.com/industrymall>

**Cax online generator**

<http://support.automation.siemens.com/WW/CAXorder/default.aspx?lang=en&mlfb=3SE5000AA26>

**Service&Support (Manuals, Certificates, Characteristics, FAQs,...)**

<http://support.automation.siemens.com/WW/view/en/3SE5000AA26/all>

**Image database (product images, 2D dimension drawings, 3D models, device circuit diagrams, EPLAN macros, ...)**

[http://www.automation.siemens.com/bilddb/cax\\_de.aspx?mlfb=3SE5000AA26&lang=en](http://www.automation.siemens.com/bilddb/cax_de.aspx?mlfb=3SE5000AA26&lang=en)

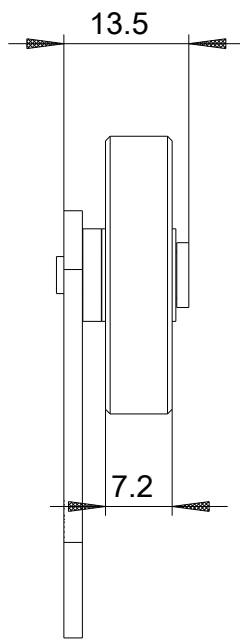
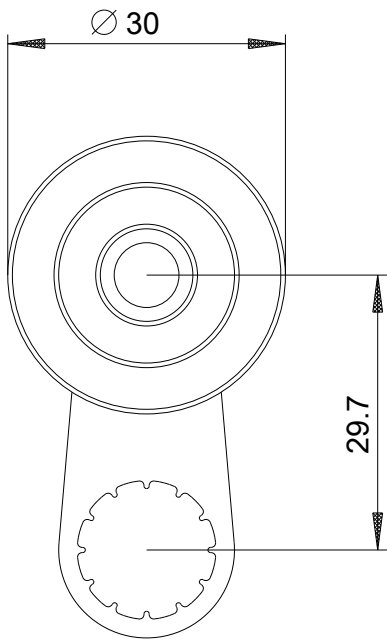

last modified:

16.03.2015