

MCU solution  
for Alexa Built-in™  
products

## MCU-Based Solution for Alexa™ Voice Service

NXP's MCU-based solution for Amazon's Alexa Voice Service (AVS) leverages the i.MX RT106A audio crossover processor, enabling developers to quickly and easily add Alexa voice assistant capabilities to their products. This turnkey design with ultra-small form factor comes completely integrated with Amazon-qualified software for an out-of-the-box AVS experience.

### OVERVIEW

NXP's MCU-based AVS solution provides OEMs with a fully integrated, self-contained, software and hardware solution that includes both the MCU and an NXP smart audio amplifier with speaker protection. It comes with all far-field audio processing algorithms including noise suppression, echo cancellation, beamforming and barge-in capabilities, to enable use in acoustically difficult environments. Also included is the Amazon Alexa client application and a machine learning inference engine for Alexa wake word identification.

This cost-effective, easy to use AVS implementation facilitates the demand for ubiquitous voice control embedded in a diverse variety of products across home, commercial and industrial applications. It eliminates the need to deploy dedicated stand-alone voice control devices such as smart speakers or smart displays.



### TARGET APPLICATIONS

The i.MX RT MCU-based solution for AVS enables designers to integrate Alexa into a wide variety of smart home, smart appliance, smart retail and smart industrial products.

- ▶ Smart switches, smart lighting, shade, and fan controls
- ▶ Smart plugs and outlets
- ▶ Smart appliances
- ▶ Set top boxes and residential gateways
- ▶ Alarm/access panels and thermostats
- ▶ Garage door openers
- ▶ Room air conditioners
- ▶ POS terminals
- ▶ Bluetooth® beacons
- ▶ Electronic shelf labels
- ▶ Industrial automation
- ▶ Hands-free process control



## i.MX106A AUDIO CROSSOVER PROCESSOR OVERVIEW

The i.MX RT106A is a solution-specific member of the i.MX RT1060 family of crossover processors, targeting cloud-based embedded voice applications. It features NXP's advanced implementation of the Arm® Cortex®-M7 core, which operates at speeds up to 600 MHz to provide high CPU performance and best real-time response. i.MX RT106A-based solution enables system designers to easily and inexpensively add voice control capabilities to a wide variety of smart appliances, smart home, smart retail, and smart industry devices. The i.MX RT106A processor is licensed to run NXP's turnkey voice assistant software solutions, which may include:

- ▶ Far-field audio front end softDSP
- ▶ Acoustic echo cancellation
- ▶ Ambient noise reduction
- ▶ Beamforming
- ▶ Barge-in
- ▶ Playback processing
- ▶ Codecs
- ▶ Wake word inference engine
- ▶ Media player/streamer
- ▶ MQTT, lwIP, TLS
- ▶ Discovery and onboarding
- ▶ All drivers, including Wi-Fi® and Bluetooth
- ▶ Supported by MCUXpresso SDK, IDE and Config Tools

## SOLUTION HARDWARE BLOCK DIAGRAM

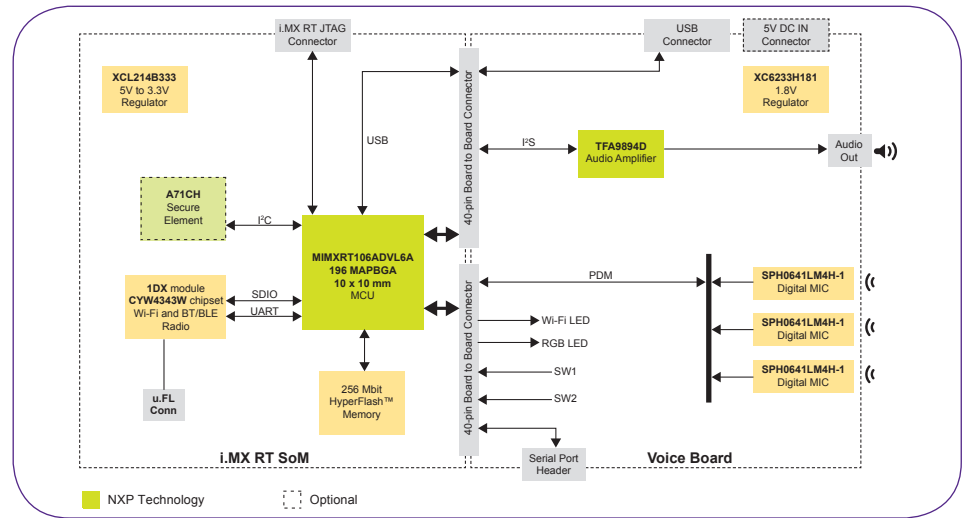

## SOLUTION SOFTWARE BLOCK DIAGRAM

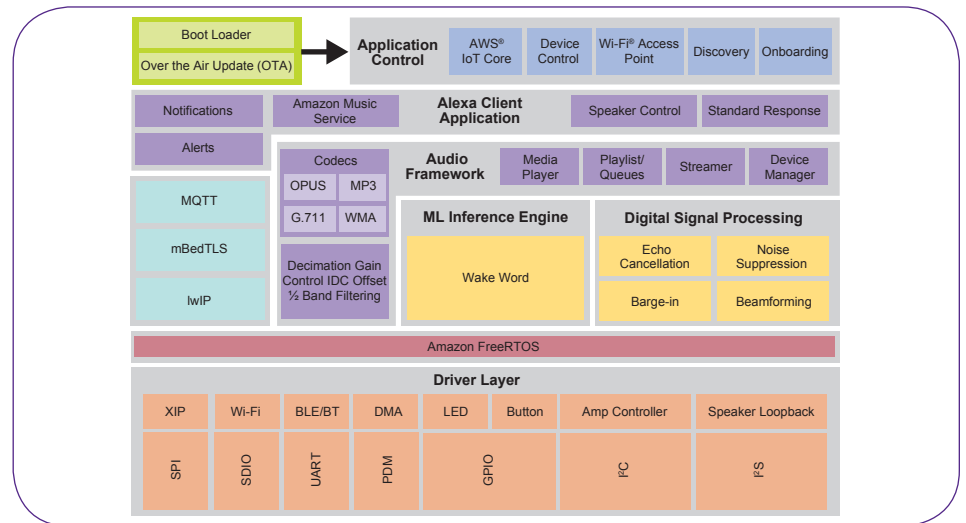

PART NUMBER	DESCRIPTION	FEATURES	DIMENSIONS
SLN-ALEXA-IOT	MCU-based Alexa Voice Service® solution evaluation and development kit	<ul style="list-style-type: none"> <li>• Turnkey, cost-optimized, production-ready, AVS-qualified solution</li> <li>• i.MX RT106A audio MCU</li> <li>• TFA9894 audio amplifier</li> <li>• A71CH secure element</li> <li>• 32 MB HyperFlash</li> <li>• 802.11 b/g/n Wi-Fi®</li> <li>• Bluetooth®/Bluetooth LE 4.2</li> <li>• Digital MEMS microphones (x3)</li> </ul>	40 mm x 30 mm dual stack 4-layer PCBs
MIMXRT106ADVL6A	i.MX RT106A Audio crossover processor	<ul style="list-style-type: none"> <li>• 600 MHz Arm® Cortex®-M7 MCU with complete voice solution software</li> <li>• 1 MB On-chip RAM</li> </ul>	10 x 10 mm 0.65 mm pitch 196-pin MAPBGA
TFA9894N2RDL2	5 W Class D smart audio amplifier	<ul style="list-style-type: none"> <li>• SPK Class-D</li> <li>• 10 V Adaptive DC-DC Boost</li> <li>• Embedded SpeakerBoost Algorithm</li> </ul>	3.55 x 2.51 mm 0.4 mm pitch WLCSP48
A7101CHTK2 (optional)	Plug and Trust secure element	<ul style="list-style-type: none"> <li>• End-to-end security, chip to edge to cloud</li> <li>• Secure credential injection for root of trust at IC level with protected access</li> <li>• Encrypted interface to host processor</li> <li>• ECC-based authentication</li> </ul>	4 x 4 mm 0.8 mm pitch HVSON8

[www.nxp.com/mcu-avs](http://www.nxp.com/mcu-avs)

NXP and the NXP logo are trademarks of NXP B.V. All other product or service names are the property of their respective owners. The Bluetooth® word mark and logos are registered trademarks owned by Bluetooth SIG, Inc. and any use of such marks by NXP Semiconductors is under license. Arm, Cortex and Mbed are trademarks or registered trademarks of Arm Limited (or its subsidiaries) in the US and/or elsewhere. The related technology may be protected by any or all of patents, copyrights, designs and trade secrets. All rights reserved. © 2019 NXP B.V.

Document Number: ALEXAVOICEFS REV 2  
Date of Release: July 2019