



Part no.: 429393
BT-2HF
Mounting bracket set

Figure can vary

Contents

- Technical data
- Dimensioned drawings

Part no.: 429393 – BT-2HF – Mounting bracket set

Technical data

Basic data

Contains	1 cylinder for mounting on the light curtain 2x BT-HF swivel mount
Suitable for	MLC 500, MLC 300 safety light curtains

Mechanical data

Type of fastening, at system	Through-hole mounting
Type of fastening, at device	Clampable
Type of mounting device	Turning, 360°
Mounting device material	Metal Plastic

Classification

Customs tariff number	76169990
eCl@ss 8.0	27279202
eCl@ss 9.0	27273701
ETIM 5.0	EC003015
ETIM 6.0	EC003015

Dimensioned drawings

All dimensions in millimeters

BT-HF swivel mount

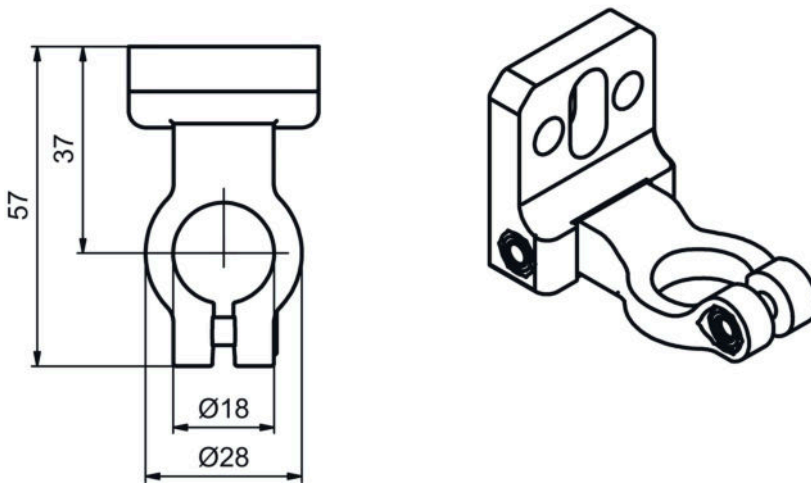
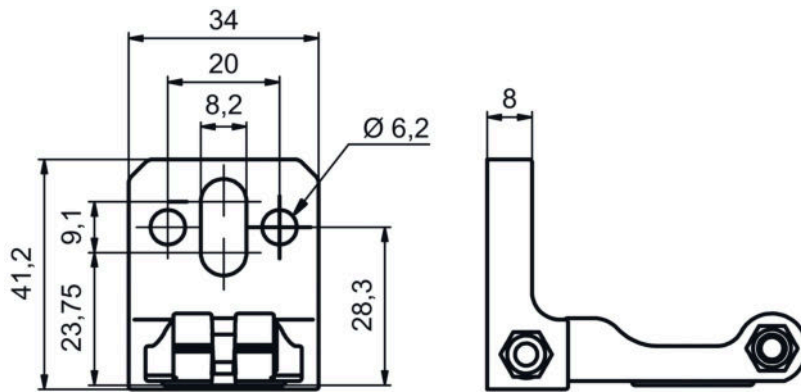

Mounting variant

