

10	9	8	7
MATERIAL NO.	ENGINEERING NO.	FINISHED LENGTH	
1300068164	105000B35M020	6'7" +3.50"-0 (2M +88.9mm-0)	
1300068165	105000B35M050	16'5" +6.50"-0 (5M +165.1mm-0)	
1300068166	105000B35M100	32'10" +12.50"-0 (10M +317.5mm-0)	
1300068167	105000B35M200	65'7" +24.50"-0 (20M +622.3mm-0)	
1300068168	105000B35M300	98'5" +24.50"-0 (30M +622.3mm-0)	

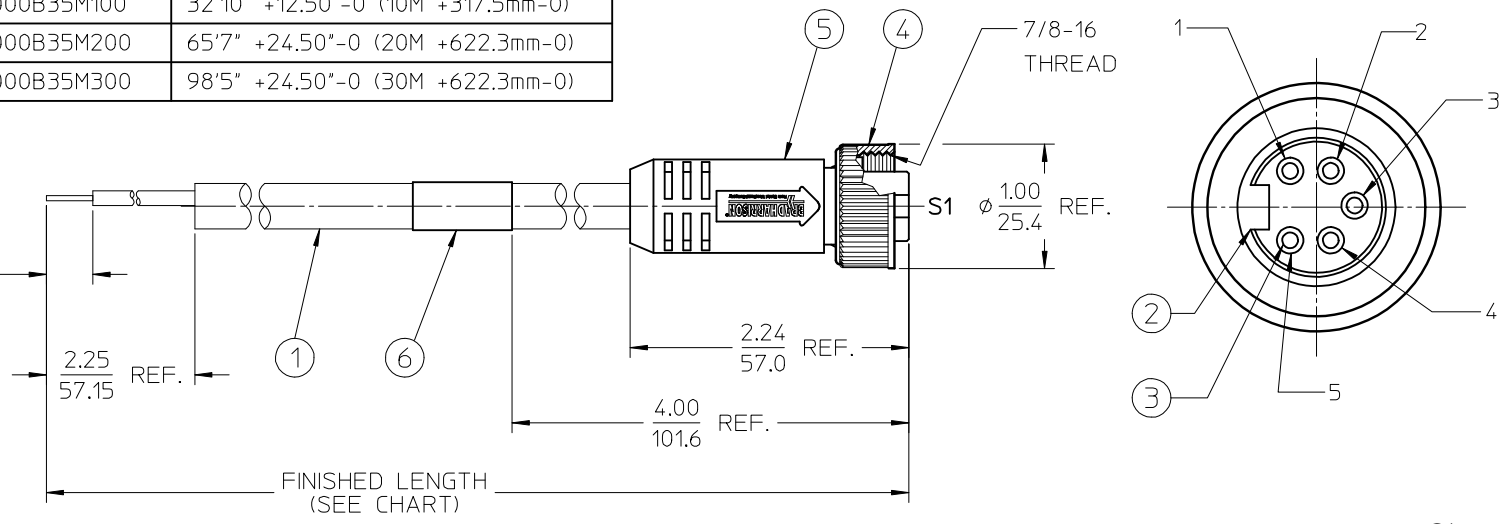

CABLE P/N MATRIX

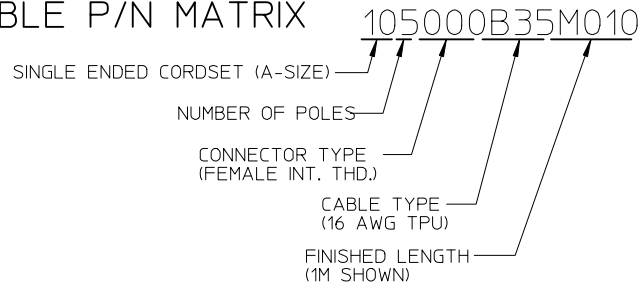

S1

1	BLACK
2	BLUE
3	GREEN/YELLOW
4	BROWN
5	WHITE

WIRING DIAGRAM

- NOTES:
1. MATERIAL: SEE TABLE
 2. FINISHES: SEE TABLE
 3. ELECTRICAL SPECIFICATIONS
VOLTAGE RATING: 300V AC/DC
CURRENT RATING: 8 AMPS
 4. PROTECTION: IP67
 5. ASSEMBLY IS RoHS COMPLIANT BY EXEMPTION

ITEM	QTY.	DESCRIPTION	MATERIAL	FINISH
6	1	WRAP LABEL	MYLAR	BLACK/YELLOW
5	1	OVERMOLD	PUR	BLACK
4	1	COUPLING RING-INT THREAD	ZINC DIE-CAST	BLACK
3	5	CONTACT SOCKET	Cu ALLOY	GOLD PLATED
2	1	INSERT, 5P	PUR	BLACK
1	A/R	CABLE 5/C, 1.5mm ² (16 AWG)	TPU JACKET	GRAY

RELEASED EC NO: IPG2014-1030 DRAWN: RSTONE 2013/12/09 CHKDK: JOZWIK 2013/12/20 APPR: JFMURPHY 2013/12/16	QUALITY SYMBOLS ▽=0 ▽=0	GENERAL TOLERANCES (UNLESS SPECIFIED)	DIMENSION STYLE IN/MM	SCALE 1:1	DESIGN UNITS INCH	THIRD ANGLE PROJECTION																
		<table border="1"> <tr> <th></th> <th>mm</th> <th>INCH</th> </tr> <tr> <td>4 PLACES</td> <td>± .15</td> <td>± .005</td> </tr> <tr> <td>3 PLACES</td> <td>± .10</td> <td>± .004</td> </tr> <tr> <td>2 PLACES</td> <td>± .07</td> <td>± .003</td> </tr> <tr> <td>1 PLACE</td> <td>± 0.3</td> <td>± .012</td> </tr> <tr> <td>0 PLACE</td> <td>± .10</td> <td>± .004</td> </tr> </table>		mm	INCH	4 PLACES	± .15	± .005	3 PLACES	± .10	± .004	2 PLACES	± .07	± .003	1 PLACE	± 0.3	± .012	0 PLACE	± .10	± .004	DRAWN BY RSTONE	DATE 2013/12/09
	mm	INCH																				
4 PLACES	± .15	± .005																				
3 PLACES	± .10	± .004																				
2 PLACES	± .07	± .003																				
1 PLACE	± 0.3	± .012																				
0 PLACE	± .10	± .004																				
DRAFT WHERE APPLICABLE MUST REMAIN WITHIN DIMENSIONS	ANGULAR ± 2°	MATERIAL NO. SEE CHART	APPROVED BY JFMURPHY	DATE 2013/12/16	DOCUMENT NO. SD-130006-049	SHEET NO. 1 OF 1																

10	9	8	7
MATERIAL NO.	ENGINEERING NO.	FINISHED LENGTH	
1300068164	105000B35M020	6'7" +3.50"-0 (2M +88.9mm-0)	
1300068165	105000B35M050	16'5" +6.50"-0 (5M +165.1mm-0)	
1300068166	105000B35M100	32'10" +12.50"-0 (10M +317.5mm-0)	
1300068167	105000B35M200	65'7" +24.50"-0 (20M +622.3mm-0)	
1300068168	105000B35M300	98'5" +24.50"-0 (30M +622.3mm-0)	

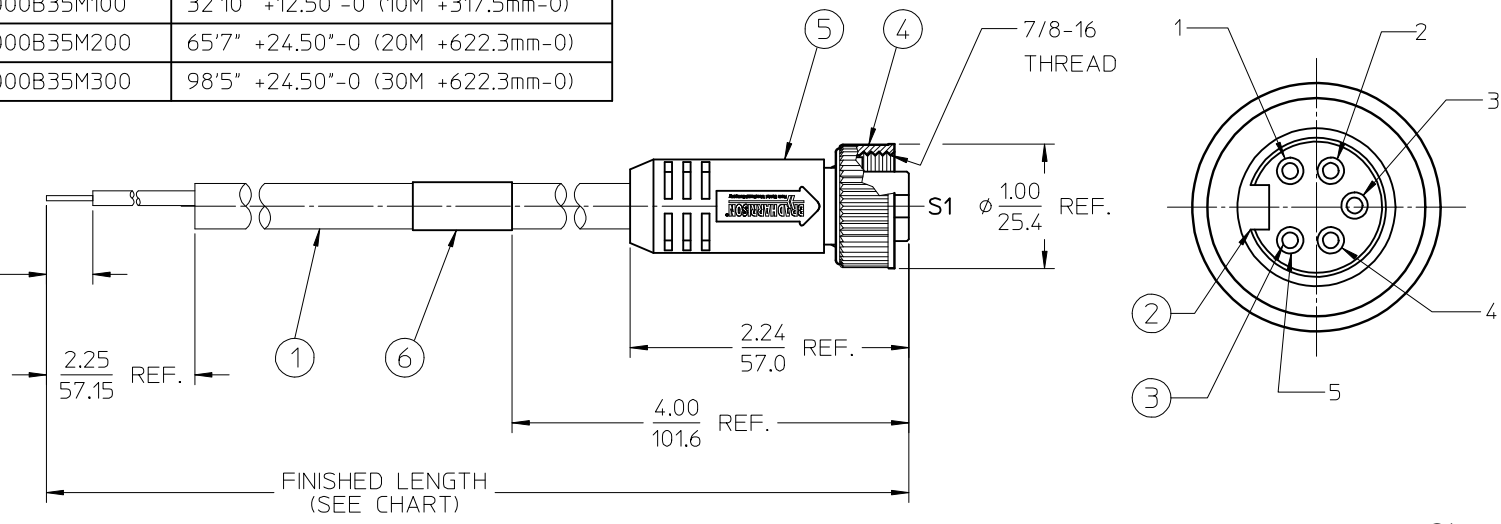

CABLE P/N MATRIX

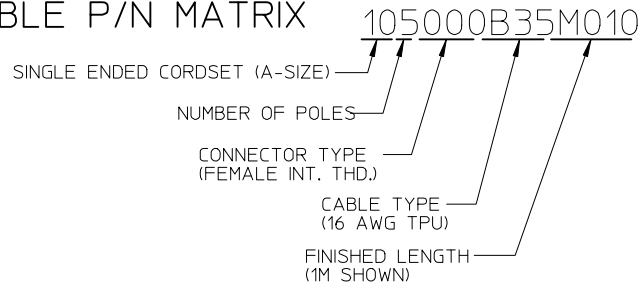

S1

1	BLACK
2	BLUE
3	GREEN/YELLOW
4	BROWN
5	WHITE

WIRING DIAGRAM

- NOTES:
1. MATERIAL: SEE TABLE
 2. FINISHES: SEE TABLE
 3. ELECTRICAL SPECIFICATIONS
VOLTAGE RATING: 300V AC/DC
CURRENT RATING: 8 AMPS
 4. PROTECTION: IP67
 5. ASSEMBLY IS RoHS COMPLIANT BY EXEMPTION

ITEM	QTY.	DESCRIPTION	MATERIAL	FINISH
6	1	WRAP LABEL	MYLAR	BLACK/YELLOW
5	1	OVERMOLD	PUR	BLACK
4	1	COUPLING RING-INT THREAD	ZINC DIE-CAST	BLACK
3	5	CONTACT SOCKET	Cu ALLOY	GOLD PLATED
2	1	INSERT, 5P	PUR	BLACK
1	A/R	CABLE 5/C, 1.5mm ² (16 AWG)	TPU JACKET	GRAY

RELEASED EC NO: IPG2014-1030 DRAWN: RSTONE 2013/12/09 CHKDK: JOZWIK 2013/12/20 APPR: JFMURPHY 2013/12/16	QUALITY SYMBOLS ▽=0 ▽=0	GENERAL TOLERANCES (UNLESS SPECIFIED)	DIMENSION STYLE IN/MM	SCALE 1:1	DESIGN UNITS INCH	THIRD ANGLE PROJECTION																
		<table border="1"> <tr> <th></th> <th>mm</th> <th>INCH</th> </tr> <tr> <td>4 PLACES</td> <td>± .15</td> <td>± .005</td> </tr> <tr> <td>3 PLACES</td> <td>± .10</td> <td>± .004</td> </tr> <tr> <td>2 PLACES</td> <td>± .07</td> <td>± .003</td> </tr> <tr> <td>1 PLACE</td> <td>± 0.3</td> <td>± .012</td> </tr> <tr> <td>0 PLACE</td> <td>± .10</td> <td>± .004</td> </tr> </table>		mm	INCH	4 PLACES	± .15	± .005	3 PLACES	± .10	± .004	2 PLACES	± .07	± .003	1 PLACE	± 0.3	± .012	0 PLACE	± .10	± .004	DRAWN BY RSTONE	DATE 2013/12/09
	mm	INCH																				
4 PLACES	± .15	± .005																				
3 PLACES	± .10	± .004																				
2 PLACES	± .07	± .003																				
1 PLACE	± 0.3	± .012																				
0 PLACE	± .10	± .004																				
DRAFT WHERE APPLICABLE MUST REMAIN WITHIN DIMENSIONS	ANGULAR ± 2°	MATERIAL NO. SEE CHART	APPROVED BY JFMURPHY	DATE 2013/12/16	DOCUMENT NO. SD-130006-049	SHEET NO. 1 OF 1																