

This document is the property of Amphenol Corporation and is delivered on the express condition that it is not to be disclosed, reproduced or used, in whole or in part, for manufacture or sale by anyone other than Amphenol Corporation without its prior consent, and that no right is granted to disclose or to use any information in this document.

CUSTOMER DRAWING ORIGINAL

SYM	ECN No.	DESCRIPTION	DATE	APPROVED
A		RELEASE FOR RoHS	09/09/2005	Henry Ko
B	NE-07023	MODIFIED DIMENSIONS TABLE & TOLERANCES	01/18/2007	HC Liu

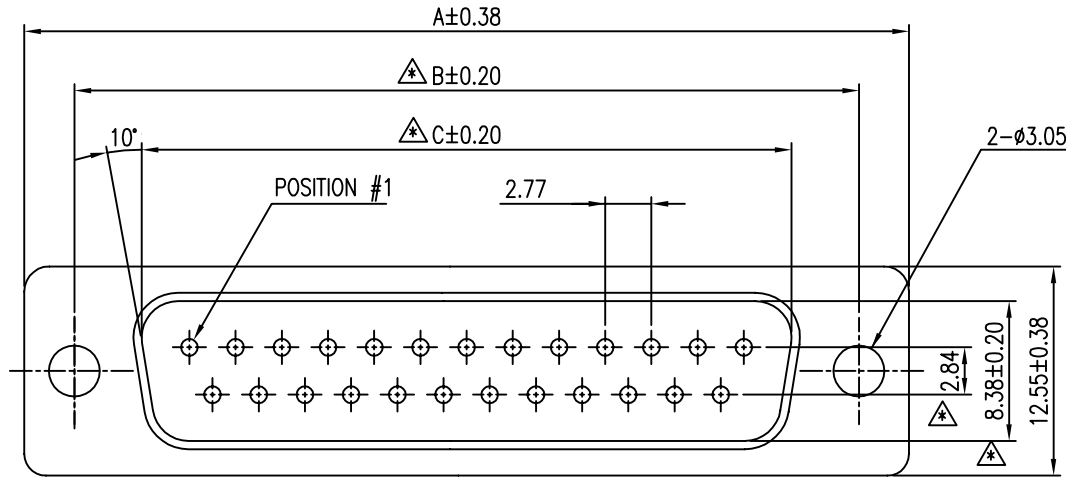

NOTES:

1. SHELL: STEEL, SELECTIVE TIN OR ZINC CHROMATED PLATED
2. CONTACTS: BRASS, SELECTIVE GOLD PLATED ON MATING AREA, TIN PLATED ON TERMINATION AREA
3. INSULATOR: PBT, UL 94V-0, COLOR- BLACK
4. THIS PRODUCT DOESN'T CONTAIN ENVIRONMENTAL HAZARDOUS MATERIALS PER DIRECTIVE 2002/95/EC FOR RoHS.
5. \triangle ARE CRITICAL DIMENSIONS

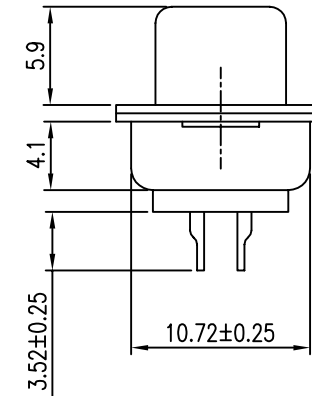
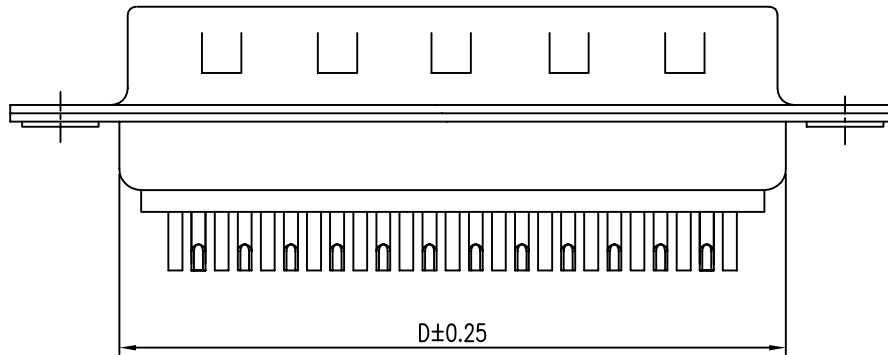

TOLERANCE m/m	
x.	±0.30
x.x	±0.25
x.xx	±0.15
x.xxx	±0.08
ANGULAR	±2°

UNLESS OTHERWISE SPECIFIED

PART NUMBERS	NO. OF CONTACTS	DIM. A	DIM. B	DIM. C	DIM. D	APPROVALS		DATE	TITLE	Amphenol® Amphenol Corporation Amphenol East Asia Limited		
						DRAWN	CHECKED	APPROVED				
G17S 09 1X XX0 EU	9	30.81	24.99	16.92	19.20	XL Wu	Sondra Sang	01/18/07	G17S SERIES SOLDER-POT TERMINATION PLUG	SCALE N.A. SHEET 1 OF 1		
G17S 15 1X XX0 EU	15	39.14	33.32	25.25	27.70		HC Liu	01/18/07				
G17S 25 1X XX0 EU	25	53.04	47.04	38.96	41.10			01/18/07				
G17S 37 1X XX0 EU	37	69.32	63.50	55.42	57.30			UNIT MM	SIZE A4	PART NO. G17S XX1X XX0 EU	DRAWING NO. DSUB-G17SXX1XXX0EU-25	REV. B