



## Turn and tilt unit PFA 9001

### Specifications

- Max. weight: 60 kg / 132 lbs
- Tilt: 20 °
- Turn: 360 °
- Guarantee: 5 years
- Available colours: Silver, Black

The PFA 9001 turn-tilt unit can be used to mount a flat display to the wall, ceiling or floor (in combination with other modular parts).



## Turn and tilt unit PFA 9001

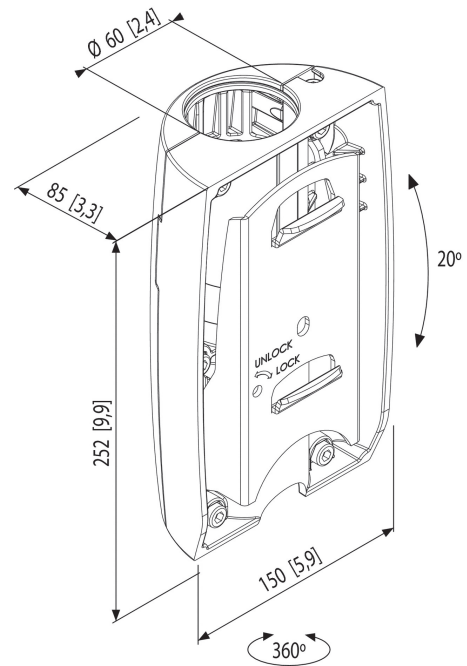

The PFA 9001 turn-tilt unit is part of a modular system which enables you to create your own ceiling or floor mounting solution for flat displays up to 60 kg. The Autolock<sup>®</sup> locking system locks the interface onto the mount and prevents the display from falling of the turn-tilt unit when accidentally lifted. The optional lock PFA 9008 blocks the locking system, hence preventing theft. The tilt indicator makes it easy to set up multiple displays at the same angle, for example at airport counters or vidi-walls (max. 20° tilt).

For ceiling mounting just add the needed ceiling plate, extension tube and universal flat display interface (FAU 3150/3125). In case of floor mounting add floor stand PFA 9011 and the needed universal flat display interface (FAU 3150/3125).

## Features

- Autolock<sup>®</sup> locking system
- Fits on PFA extension tubes and standard 60 mm tube
- Turn and 20° tilt function
- Suitable for interfaces FAU 3125 or FAU 3150

## Logistic information

- Packaging size: 160x262x149 mm
- Max. weight: 3 kg / 7 lbs
- EAN Code: 8712285305467