

**DISPLAY Elektronik GmbH**

# DATA SHEET

**LCD MODULE**

## **DEM 20487 SBH-PW-N**

*Product specification*

*Version: 7*

**24.Aug.2011**

# GENERAL SPECIFICATION

---

MODULE NO. :

# DEM 20487 SBH-PW-N

CUSTOMER P/N

VERSION NO.	CHANGE DESCRIPTION	DATE
0	ORIGINAL VERSION	08.05.2008
1	ADD VERSION	21.05.2008
2	UPDATE MECHANICAL DRAWING	10.06.2008
3	UPDATE PCB DESCRIPTION	18.09.2008
4	ADD VERSION	14.04.2011
5	CHANGE BACKLIGHT RESISTOR	27.04.2011
6	UPDATE BACKLIGHT	02.06.2011
7	ADD VERSION	24.08.2011

PREPARED BY: LX

DATE: 24.08.2011

APPROVED BY: MHO

DATE: 24.08.2011

**CONTENTS**

**1. FUNCTIONS & FEATURES ..... 2**

**2. MECHANICAL SPECIFICATIONS ..... 2**

**3. EXTERNAL DIMENSIONS ..... 3**

**4. BLOCK DIAGRAM ..... 3**

**5. PIN ASSIGNMENT ..... 4**

**6. PCB DRAWING AND DESCRIPTION ..... 4**

**7. BACKLIGHT ELECTRICAL/OPTION CHARACTERISTICS ..... 6**

**8. DISPLAY DATA RAM (DDRAM) ..... 7**

**9. MAXIMUM ABSOLUTE LIMIT (TA=25°C) ..... 7**

**10. ELECTRICAL CHARACTERISTICS ..... 7**

**12. STANDARD CHARACTER PATTERN ..... 10**

**13. LCM INITIALIZING BY INSTRUCTION ..... 11**

**14. LCD MODULES HANDLING PRECAUTIONS ..... 13**

**15. OTHERS ..... 13**

**1. FUNCTIONS & FEATURES**

MODULE	LCD TYPE
DEM 20487 SBH-PW-N	STN Blue Transmissive Negative Mode

- Viewing Direction : 6 O'clock
- Driving Scheme : 1/16 Duty Cycle, 1/5 Bias
- Power Supply Voltage : 5.0 Volt (typ.)
- Backlight Color : White
- VLCD : 4.5 Volt (typ.)
- Display contents : 20x4 Characters
- Internal Memory : CGROM (13200 bits )  
: CGRAM (64 x 8 bits )  
: DDRAM (80 x 8 bits for Digits)
- Interface : Easy Interface with a 4-bit or 8-bit MPU
- ROHS : Compliant

**2. MECHANICAL SPECIFICATIONS**

- Module Size : 146,00 x 62,50 x 14,00 mm
- Character Pitch : 6,00 x 9,75 mm
- Character Size : 4,85 x 9,23 mm
- Character Font : 5 x 8 dots
- Dot Size : 0,93 x 1,11 mm
- Dot Pitch : 0,98 x 1,16 mm

3. EXTERNAL DIMENSIONS

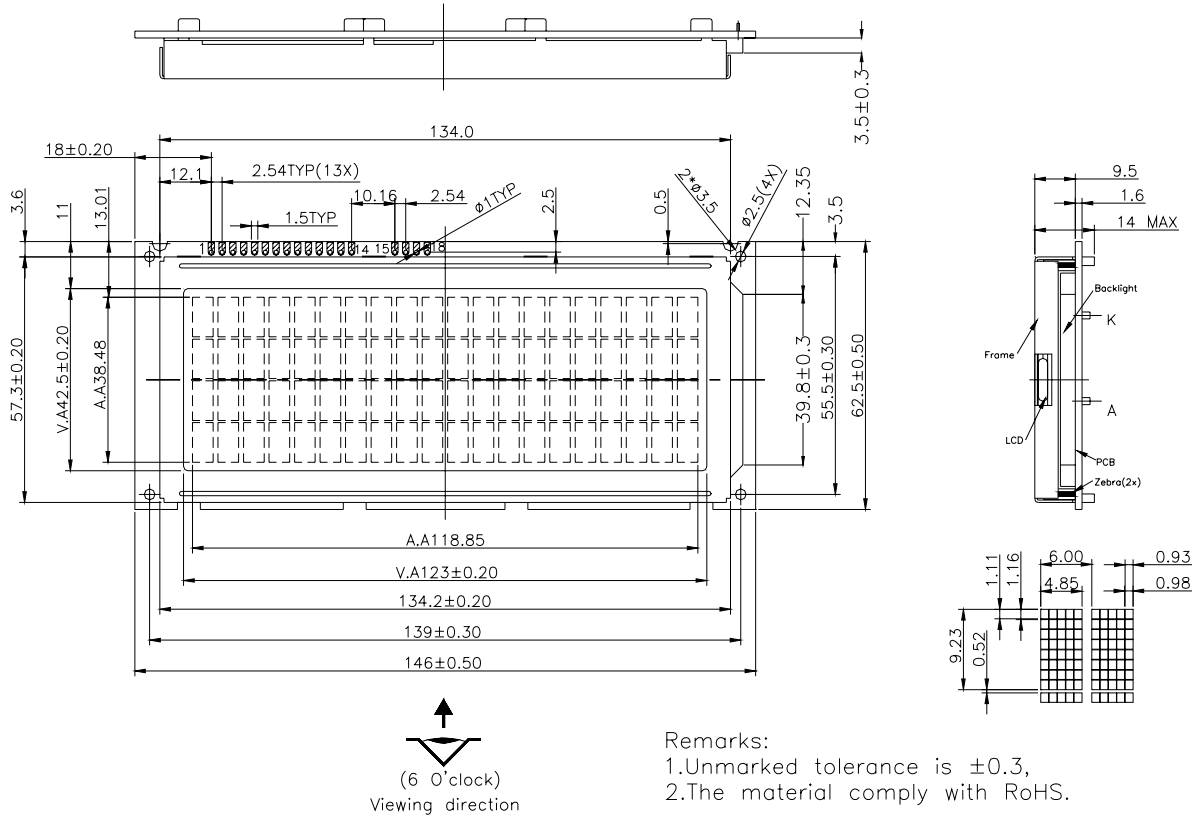

4. BLOCK DIAGRAM

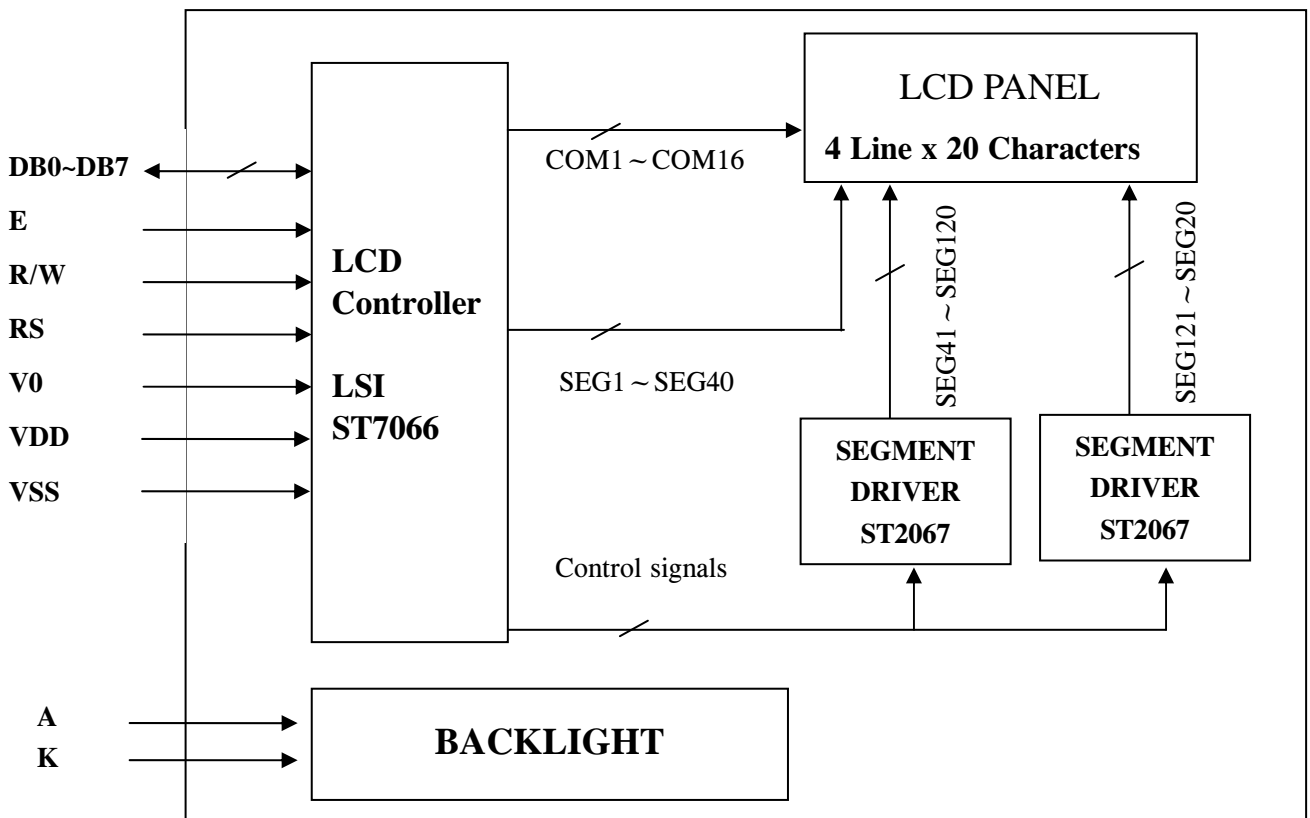

5. PIN ASSIGNMENT

Pin No.	Symbol	Function
1	V <sub>SS</sub>	Ground terminal of module
2	V <sub>DD</sub>	Power supply of module 5V
3	V <sub>0</sub>	Power Supply for LCD
4	RS	Register Select RS=0: Instruction Register; RS=1: Data Register
5	R/W	Read / Write R/W=0: Read; R/W=1: Write
6	E	Enable
7	DB0	Bi-directional data bus, data transfer is performed once, thru DB0~DB7, in the case of interface data. Length is 8-bit; and twice, thru DB4~DB7 in the case of interface data length is 4-bits. Upper four bits first then lower four bits.
8	DB1	
9	DB2	
10	DB3	
11	DB4	
12	DB5	
13	DB6	
14	DB7	
15	LED-(K)	Please also refer to 6.1 PCB drawing and description.
16	LED+(A)	
17	NC	No connect
18	NC	No connect

6. PCB DRAWING AND DESCRIPTION

6.1 PCB DRAWING

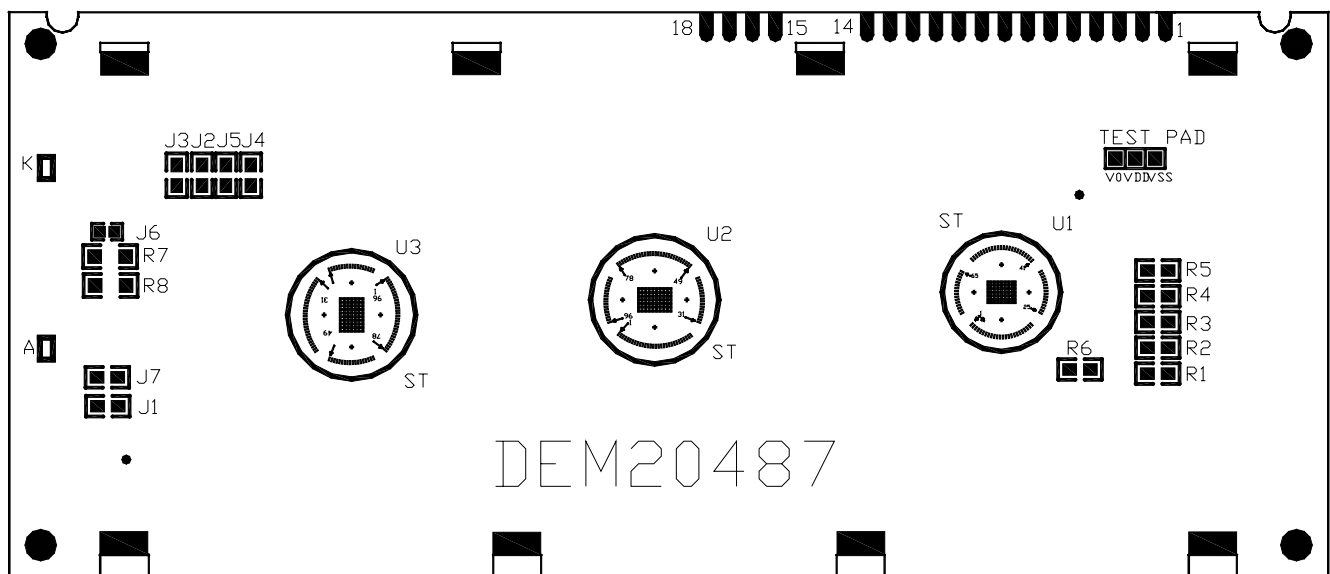

Note: The PCB drawing just for reference!! The "DEM20487" Print on the front side of PCB.

**DESCRIPTION:**

**6-1-1. The polarity of the pin 15 and the pin 16:**

J3,J5	J2, J4	LED Polarity	
		15 Pin	16 Pin
Each open	Each closed	Anode	Cathode
Each closed	Each open	Cathode	Anode

Note: In application module, J2=J4= open and J3=J5=0 Ohm.

**6-1-2. The metal-bezel is set be on ground when the J1 is closed.**

Note: In application module, J1=0 Ohm.

**6-1-3. The LED resistor on board is used when J6 is open.**

Note: In application module, J6=open.

**6-1-4. The R7 and the R8 are the LED resistor.**

Note: In application module, R7=R8=33 Ohm.

**6-1-5. The mounting holes is set on ground when the J7 is closed.**

Note: In application module, J7=0 Ohm.

**6.2 Example application**

6-2-1. The LED resistor should be bridged as following.

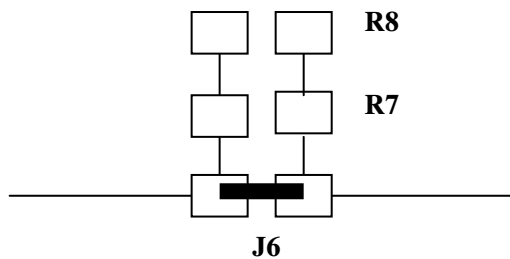

6-2-2. The 15 pin is the anode and the 16 pin is the cathode as following.



6-2-3. The 15 pin is the cathode and the 16 pin is the anode as following.



6-2-4. The metal-bezel is on ground as following.



7. BACKLIGHT ELECTRICAL/OPTION CHARATERISTICS

ELECTRICAL / OPTICAL SPECIFICATIONS

PARAMETER	STMBOL	Min.	Typ.	Max	Unit	Test condition
AVERAGE LUMINOUS INTENSITY	$I_v$	200	300		cd/m <sup>2</sup>	Ta=25°C Vf=4.1V
LUMINOUS TOLERANCE / PCS		70			%	
FORWARD CURRENT	$I_f$			80	mA	
PEAK EMISSION WAVELENGTH	$\lambda_p$				nm	
CHROMATICITY COORDINATES	X Y	0.28 0.28	0.31 0.31	0.34 0.34		
ITEM	STMBOL	ABS. MAXIMUN RATING			TEST CONDITION	
FORWARD CURRENT	$I_f$	80mA			Ta=25°C	
REVERSE VOLTAGE	$V_r$	5				
POWER DISSIPATION	$P_d$	328mW				
OPERATING TEMPERATURE	$T_{opr}$	-20 ~ +70°C				
STORAGE TEMPERATURE	$T_{stg}$	-25 ~ +75°C				

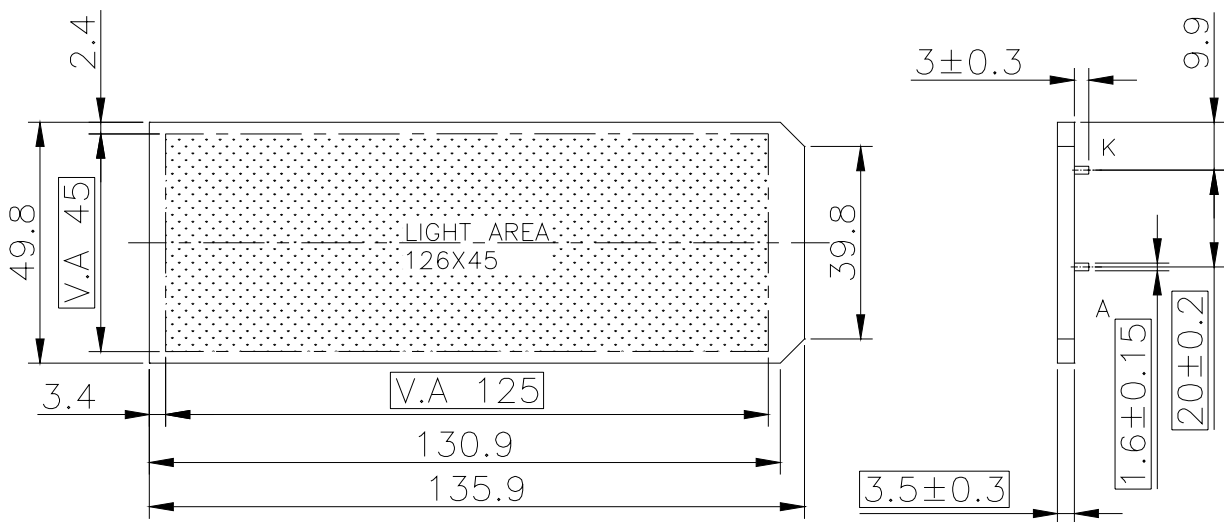

REMARKS:  
 1, UNMARKED TOLERANCE IS ±0.3,  
 2, THE MATERIAL COMPLY WITH ROHS,  
 3, COLOR : WHITE.

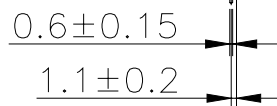

INTERNAL CIRCUIT DIAGRAM

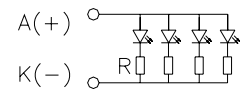



8. DISPLAY DATA RAM (DDRAM)

	1	2	3	4	5	6	7	8	9	10	11	12	13	14	15	16	17	18	19	20	← DISPLAY POSITION
FIRST LINE	00	01	02	03	04	05	06	07	08	09	0A	0B	0C	0D	0E	0F	10	11	12	13	← DDRAM ADDRESS
SECOND LINE	40	41	42	43	44	45	46	47	48	49	4A	4B	4C	4D	4E	4F	50	51	52	53	
THIRDD LINE	14	15	16	17	18	19	1A	1B	1C	1D	1E	1F	20	21	22	23	24	25	26	27	
FOURTH LINE	54	55	56	57	58	59	5A	5B	5C	5D	5E	5F	60	61	62	63	64	65	66	67	

9. MAXIMUM ABSOLUTE LIMIT (Ta=25°C)

Item	Symbol	Standard value	Unit
Power supply voltage (1)	V <sub>DD</sub>	-0.3~+7.0	V
Power supply voltage (2)	V <sub>0</sub>	V <sub>DD</sub> -10.0~V <sub>DD</sub> +0.3	V
Input voltage	V <sub>IN</sub>	-0.3~V <sub>DD</sub> +0.3	V
Operating temperature	T <sub>opr</sub>	-20~+70	°C
Storage temperature	T <sub>stg</sub>	-25~+75	°C

\*Voltage greater than above may damage to the Circuit.

$$V_{DD} > V1 > V2 > V3 > V4 > V5$$

10. ELECTRICAL CHARACTERISTICS

10-1 DC Characteristics(VDD=5V,Ta=25°C)

Item	Symbol	Standard Value			Test Condition	Unit
		MIN	TYP	MAX		
Operating Voltage	V <sub>DD</sub>	4.7	5.0	5.3	-----	V
LCD Driving Voltage	V <sub>LCD</sub>	4.2	4.5	4.8	V <sub>DD</sub> -V5	V
Consume Current	I <sub>DD</sub>	----	TBD	----	-----	uA

10-2. AC Characteristics (VDD=5V , Ta=25°C)

10-2-1 Write mode (writing data from MPU to module)

Characteristic	Symbol	Min	Type	Max	Unit	Test PIN
E Cycle Time	t <sub>C</sub>	1200	---	---	ns	E
E Rise Time	t <sub>R</sub>	---	---	25	ns	E
E Fall Time	t <sub>F</sub>	---	---	25	ns	E
E Pulse width (High,Low)	t <sub>PW</sub>	140	---	---	ns	E
R/W and RS Set-up Time	t <sub>AS</sub>	0	---	---	ns	R/W,RS,E
R/W and RS Hold Time	t <sub>AH</sub>	10	---	---	ns	R/W,RS,E
Data Set-up Time	t <sub>DSW</sub>	40	---	---	ns	DB0~DB7
Data Hold Time	t <sub>H</sub>	10	---	---	ns	DB0~DB7

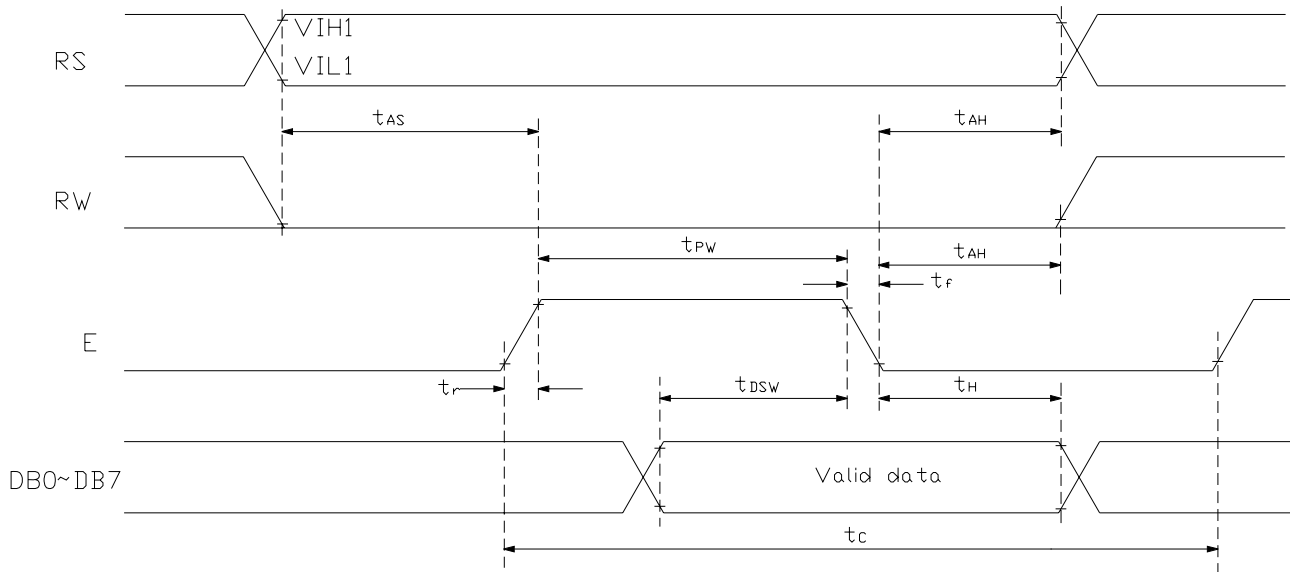

10-2-2 Read mode (reading data from module to MPU)

Characteristic	Symbol	Min	Type	Max	Unit	Test PIN
E Cycle Time	$t_c$	1200	---	---	ns	E
E Rise Time	$t_R$	---	---	25	ns	E
E Fall Time	$t_F$	---	---	25	ns	E
E Pulse width (High, Low)	$t_{PW}$	140	---	---	ns	E
R/W and RS Set-up Time	$t_{AS}$	0	---	---	ns	R/W,RS
R/W and RS Hold Time	$t_{AH}$	10	---	---	ns	R/W,RS
Data Setup Time	$t_{DDR}$	---	---	100	ns	DB0~DB7
Data Hold Time	$t_H$	10	---	---	ns	DB0~DB7

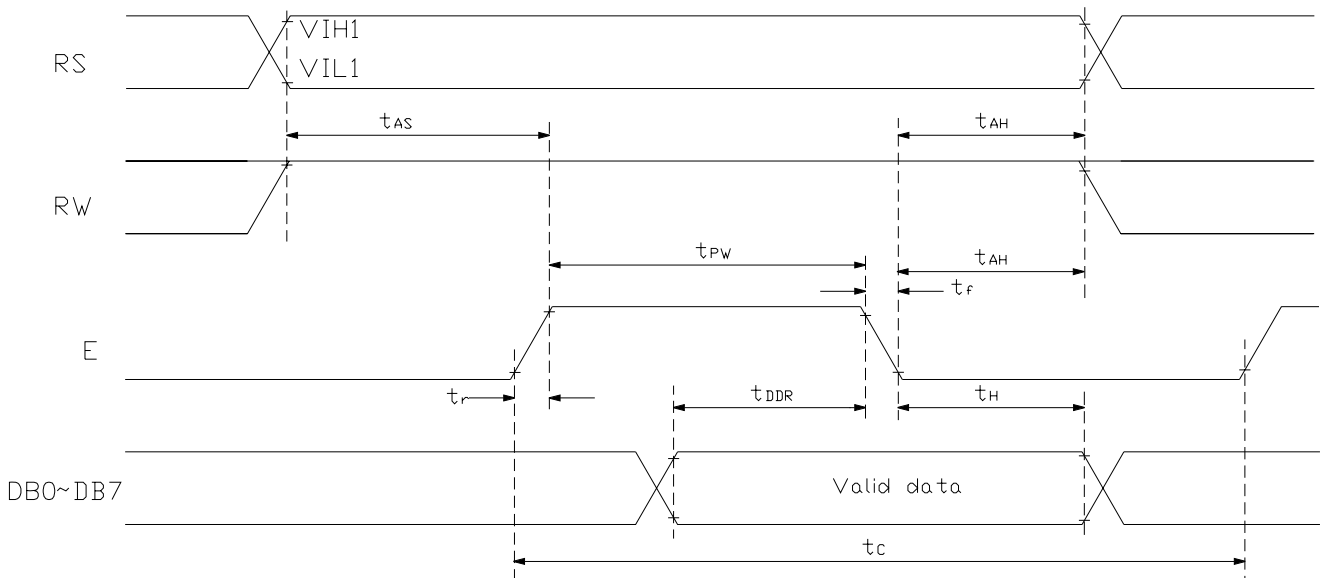

## 11. CONTROL AND DISPLAY COMMAND

Instruction	Instruction Code										Description	Description Time (270KHz)	
	RS	R/W	DB7	DB6	DB5	DB4	DB3	DB2	DB1	DB0			
Clear Display	D	D	D	D	D	D	D	D	D	D	1	Write "20H" to DDRAM, and set DDRAM address to "00H" from AC	1.52 ms
Return Home	D	D	D	D	D	D	D	D	D	1	x	Set DDRAM address to "00H" from AC and return cursor to its original position if shifted. The contents of DDRAM are not changed.	1.52 ms
Entry Mode Set	D	D	D	D	D	D	D	D	1	I/D	S	Sets cursor move direction and specifies display shift. These operations are performed during data write and read.	37 us
Display ON/OFF	D	D	D	D	D	D	D	1	D	C	B	D=1:entire display on C=1:cursor on B=1:cursor position on	37 us
Cursor or Display Shift	D	D	D	D	D	D	1	S/C	R/L	x	x	Set cursor moving and display shift control bit, and the direction, without changing DDRAM data.	37 us
Function Set	D	D	D	D	D	1	DL	N	F	x	x	DL:interface data is 8/4 bits N:number of line is 2/1 F:font size is 5x11/5x8	37 us
Set CGRAM address	D	D	D	1	AC5	AC4	AC3	AC2	AC1	ACD		Set CGRAM address in address counter	37 us
Set DDRAM address	D	D	1	AC6	AC5	AC4	AC3	AC2	AC1	ACD		Set DDRAM address in address counter	37 us
Read Busy flag and address	D	1	BF	AC6	AC5	AC4	AC3	AC2	AC1	ACD		Whether during internal operation or not can be known by reading BF. The contents of address counter can also be read.	0 us
Write data to RAM	1	D	D7	D6	D5	D4	D3	D2	D1	D0		Write data into internal RAM (DDRAM/CGRAM)	37 us
Read data from RAM	1	1	D7	D6	D5	D4	D3	D2	D1	D0		Read data from internal RAM (DDRAM/CGRAM)	37 us

**Note:**

Be sure the ST7066U is not in the busy state (BF = 0) before sending an instruction from the MPU to the ST7066U. If an instruction is sent without checking the busy flag, the time between the first instruction and next instruction will take much longer than the instruction time itself. Refer to Instruction Table for the list of each instruction execution time.

12. STANDARD CHARACTER PATTERN

NO.7066-0A

$b_7-b_4$ $b_3-b_0$	0000	0001	0010	0011	0100	0101	0110	0111	1000	1001	1010	1011	1100	1101	1110	1111
0000	CG RAM (1)															
0001	(2)															
0010	(3)															
0011	(4)															
0100	(5)															
0101	(6)															
0110	(7)															
0111	(8)															
1000	(1)															
1001	(2)															
1010	(3)															
1011	(4)															
1100	(5)															
1101	(6)															
1110	(7)															
1111	(8)															

13. LCM INITIALIZING BY INSTRUCTION

- 8-bit Interface (fosc=270KHz)

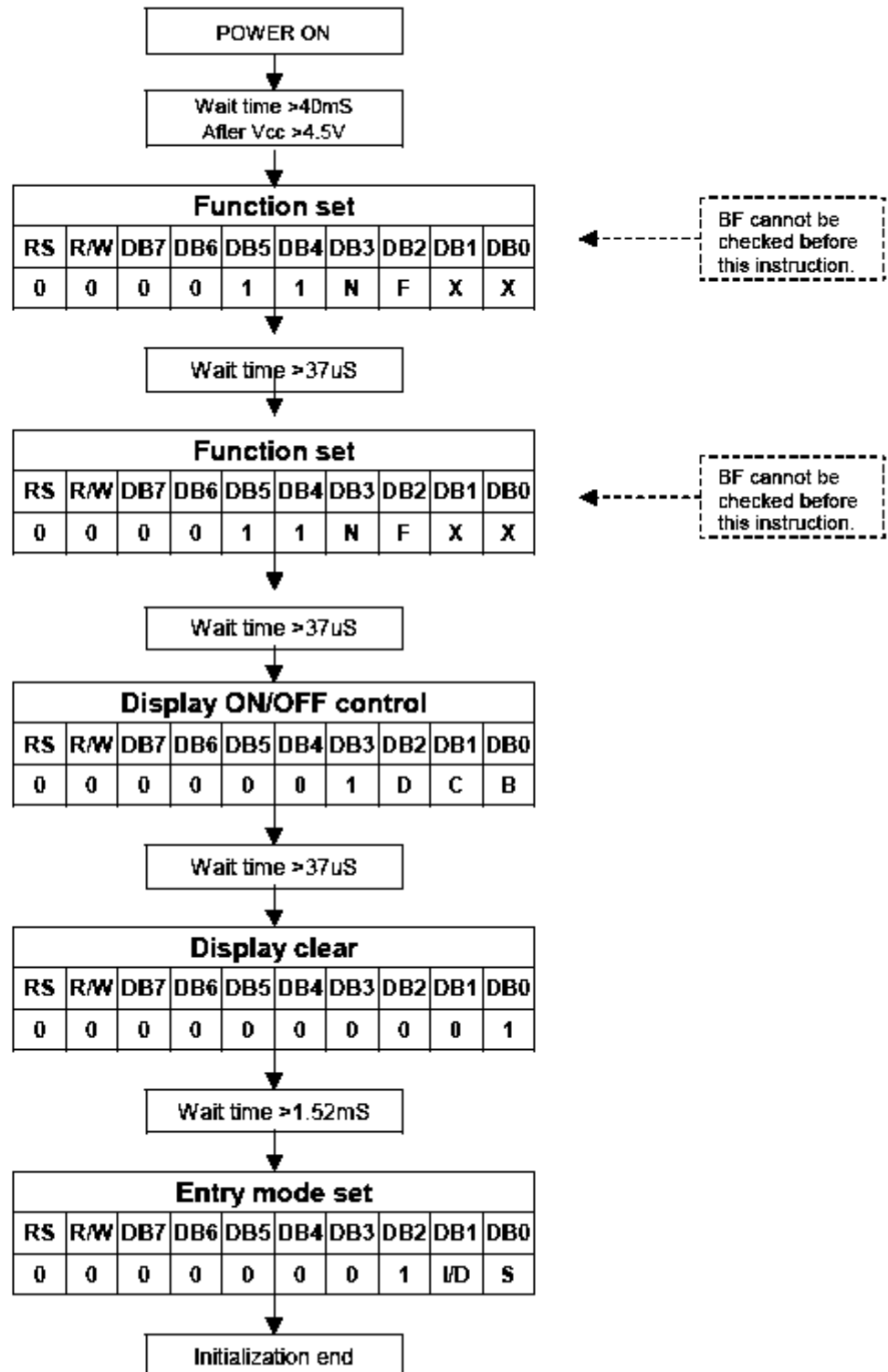

● 4-bit Interface (fosc=270KHz)

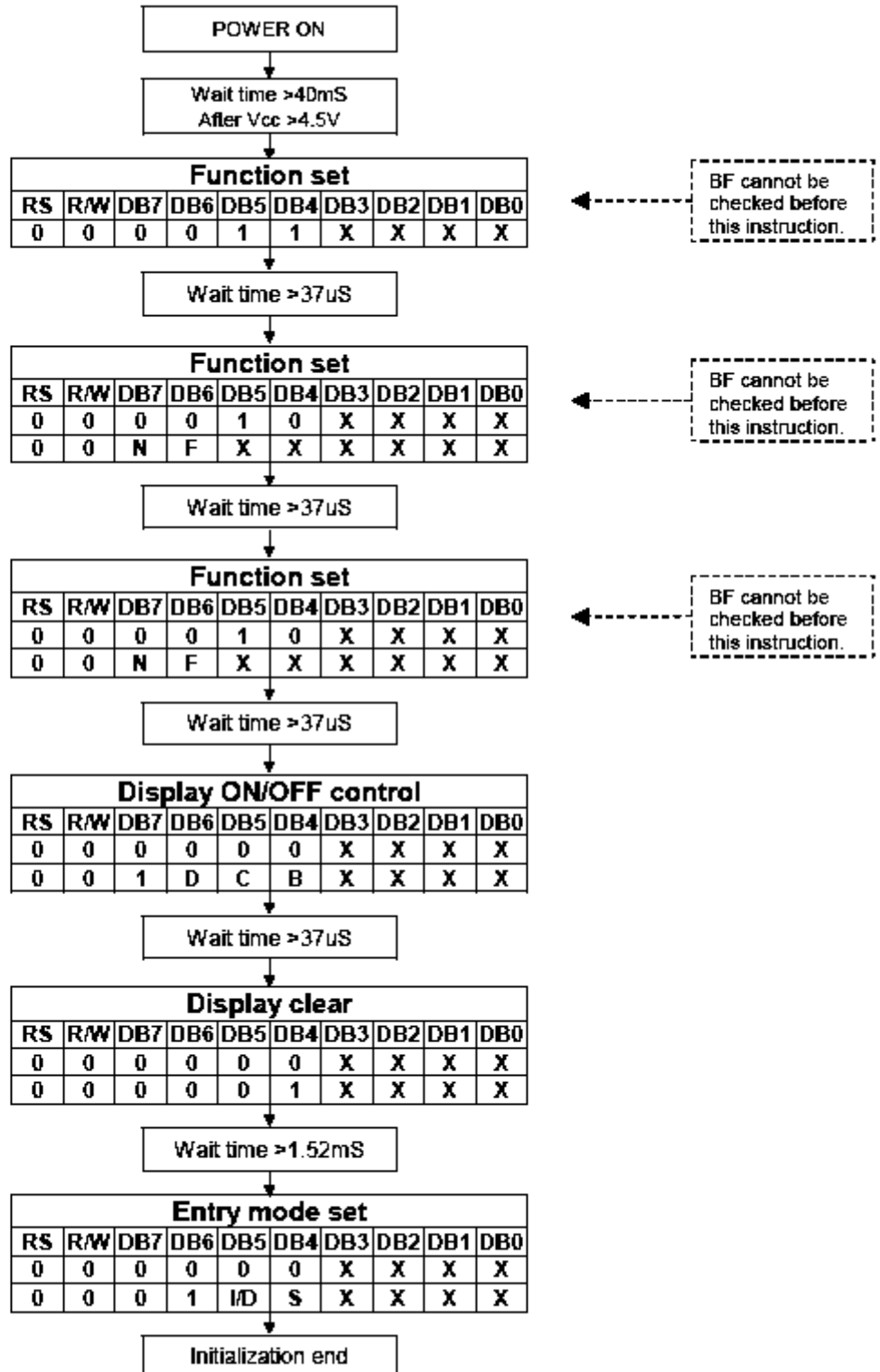

**14. LCD Modules Handling Precautions**

- The display panel is made of glass. Do not subject it to a mechanical shock by dropping it from a high place, etc.
- If the display panel is damaged and the liquid crystal substance inside it leaks out, do not get any in your mouth. If the substance come into contact with your skin or clothes promptly wash it off using soap and water.
- Do not apply excessive force to the display surface or the adjoining areas since this may cause the color tone to vary.
- The polarizer covering the display surface of the LCD module is soft and easily scratched. Handle this polarize carefully.
- To prevent destruction of the elements by static electricity, be careful to maintain an optimum work environment.
  - Be sure to ground the body when handling the LCD module.
  - Tools required for assembly, such as soldering irons, must be properly grounded.
  - To reduce the amount of static electricity generated, do not conduct assembly and other work under dry conditions.
  - The LCD module is coated with a film to protect the display surface. Exercise care when peeling off this protective film since static electricity may be generated.
- Storage precautions  
When storing the LCD modules, avoid exposure to direct sunlight or to the light of fluorescent lamps. Keep the modules in bags designed to prevent static electricity charging under low temperature / normal humidity conditions (avoid high temperature / high humidity and low temperatures below 0°C).Whenever possible, the LCD modules should be stored in the same conditions in which they were shipped from our company.

**15. Others**

- Liquid crystals solidify at low temperature (below the storage temperature range) leading to defective orientation of liquid crystal or the generation of air bubbles (black or white). Air bubbles may also be generated if the module is subjected to a strong shock at a low temperature.
- If the LCD modules have been operating for a long time showing the same display patterns may remain on the screen as ghost images and a slight contrast irregularity may also appear. Abnormal operating status can be resumed to be normal condition by suspending use for some time. It should be noted that this phenomena does not adversely affect performance reliability.
- To minimize the performance degradation of the LCD modules resulting from caused by static electricity, etc. exercise care to avoid holding the following sections when handling the modules:
  - Exposed area of the printed circuit board
  - Terminal electrode sections