

# GN 612.3 | Lever indexing plungers

Rest position, steel or stainless steel

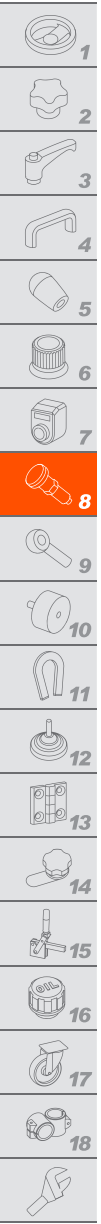

## PLUNGER

Nitrided steel.  
AISI 303 stainless steel (NI)

## SPRING

AISI 301 stainless steel.

## LEVER COVER

High-resilience polyamide based (PA) technopolymer, black colour, matte finish.

## STANDARD EXECUTIONS

- **GN 612.3-A:** welding black-oxide steel body, without lever cover.
- **GN 612.3-A-NI:** welding AISI 304 stainless steel body, without lever cover.
- **GN 612.3-B:** welding black-oxide steel body, with lever cover.
- **GN 612.3-B-NI:** welding AISI 304 stainless steel body, with lever cover.

## FEATURES AND APPLICATIONS

GN 612.3 indexing plungers are used when the plunger must be retracted quickly. They are especially designed for assembly by means of welding. By rotating the lifting lever by 180°, a notch keeps the plunger in the retracted position.



GN 612.3-A  
GN 612.3-A-NI

GN 612.3-B  
GN 612.3-B-NI

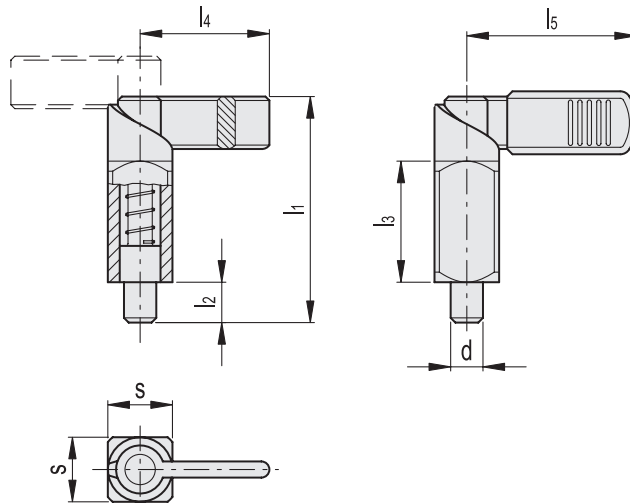

Indexing and positioning elements



## GN 612.3-A

Code	Description	d1 Plunger -0.02-0.04 Hole +0.14 +0.10	l1	l2	l3	l4	s	Spring preload [N]	Spring max load [N]	
GN.34471	GN 612.3-6-16-A	6	56	10	30	32	16	12	32	76
GN.34476	GN 612.3-8-16-A	8	56	10	30	32	16	12	32	80
GN.34481	GN 612.3-8-20-A	8	69	12	38	37	20	21	58	151
GN.34486	GN 612.3-10-16-A	10	56	10	30	32	16	12	32	80
GN.34491	GN 612.3-10-20-A	10	69	12	38	37	20	21	58	153
GN.34496	GN 612.3-12-20-A	12	69	12	38	37	20	21	58	158

## GN 612.3-B

Code	Description	d1 Plunger -0.02-0.04 Hole +0.14 +0.10	l1	l2	l3	l5	s	Spring preload [N]	Spring max load [N]	
GN.34472	GN 612.3-6-16-B	6	56	10	30	42	16	12	32	78
GN.34477	GN 612.3-8-16-B	8	56	10	30	42	16	12	32	80
GN.34482	GN 612.3-8-20-B	8	69	12	38	52	20	21	58	154
GN.34487	GN 612.3-10-16-B	10	56	10	30	42	16	12	32	82
GN.34492	GN 612.3-10-20-B	10	69	12	38	52	20	21	58	157
GN.34497	GN 612.3-12-20-B	12	69	12	38	52	20	21	58	174

## GN 612.3-A-NI

INOX STAINLESS STEEL

Code	Description	d1 Plunger -0.02-0.04 Hole +0.14 +0.10	l1	l2	l3	l4	s	Spring preload [N]	Spring max load [N]	
GN.34473	GN 612.3-6-16-A-NI	6	56	10	30	32	16	12	32	76
GN.34478	GN 612.3-8-16-A-NI	8	56	10	30	32	16	12	32	80
GN.34483	GN 612.3-8-20-A-NI	8	69	12	38	37	20	21	58	151
GN.34488	GN 612.3-10-16-A-NI	10	56	10	30	32	16	12	32	80
GN.34493	GN 612.3-10-20-A-NI	10	69	12	38	37	20	21	58	153
GN.34498	GN 612.3-12-20-A-NI	12	69	12	38	37	20	21	58	158

## GN 612.3-B-NI

INOX STAINLESS STEEL

Code	Description	d1 Plunger -0.02-0.04 Hole +0.14 +0.10	l1	l2	l3	l5	s	Spring preload [N]	Spring max load [N]	
GN.34474	GN 612.3-6-16-B-NI	6	56	10	30	42	16	12	32	78
GN.34479	GN 612.3-8-16-B-NI	8	56	10	30	42	16	12	32	80
GN.34484	GN 612.3-8-20-B-NI	8	69	12	38	52	20	21	58	154
GN.34489	GN 612.3-10-16-B-NI	10	56	10	30	42	16	12	32	82
GN.34494	GN 612.3-10-20-B-NI	10	69	12	38	52	20	21	58	157
GN.34499	GN 612.3-12-20-B-NI	12	69	12	38	52	20	21	58	174