

# Small Engine Management Evaluation Board

## User Manual for TLE8082ES+TLE8080EM Evaluation Board

### About this document

This document explains how the Evaluation Board of TLE8082ES + TLE8080EM is taken into operation. The required hardware and software components for the evaluation are documented. For a detailed description of the hardware components, see the datasheets of TLE8080EM and TLE8082ES.

### Intended audience

This document is intended for anyone who uses Infineon's small engine management solution. The Evaluation board uses TLE8080EM and its brand new companion IC TLE8082ES to provide a comprehensive motorcycle engine control design.

### Table of contents

<b>About this document</b> .....	<b>1</b>
<b>Table of contents</b> .....	<b>1</b>
<b>1 Hardware</b> .....	<b>2</b>
1.1 XMC Hardware setup .....	3
1.1.1 Output connectors .....	4
1.1.2 Connector Interface for Arduino.....	5
1.1.3 Measurement and Jumper Options.....	8
1.1.4 LEDs .....	10
1.2 Schematic and Layout.....	10
<b>2 Software</b> .....	<b>13</b>
2.1 XMC setup .....	13
2.2 Aurix ShieldBuddy TC275.....	14
2.3 Flash Arduino script .....	14
<b>3 Application Example: Current Measurement with TLE8082 CFB</b> .....	<b>16</b>
<b>Revision history</b> .....	<b>17</b>

# 1 Hardware

Figure 1 provides an overview on the TLE8082ES+TLE8080EM Evaluation board.

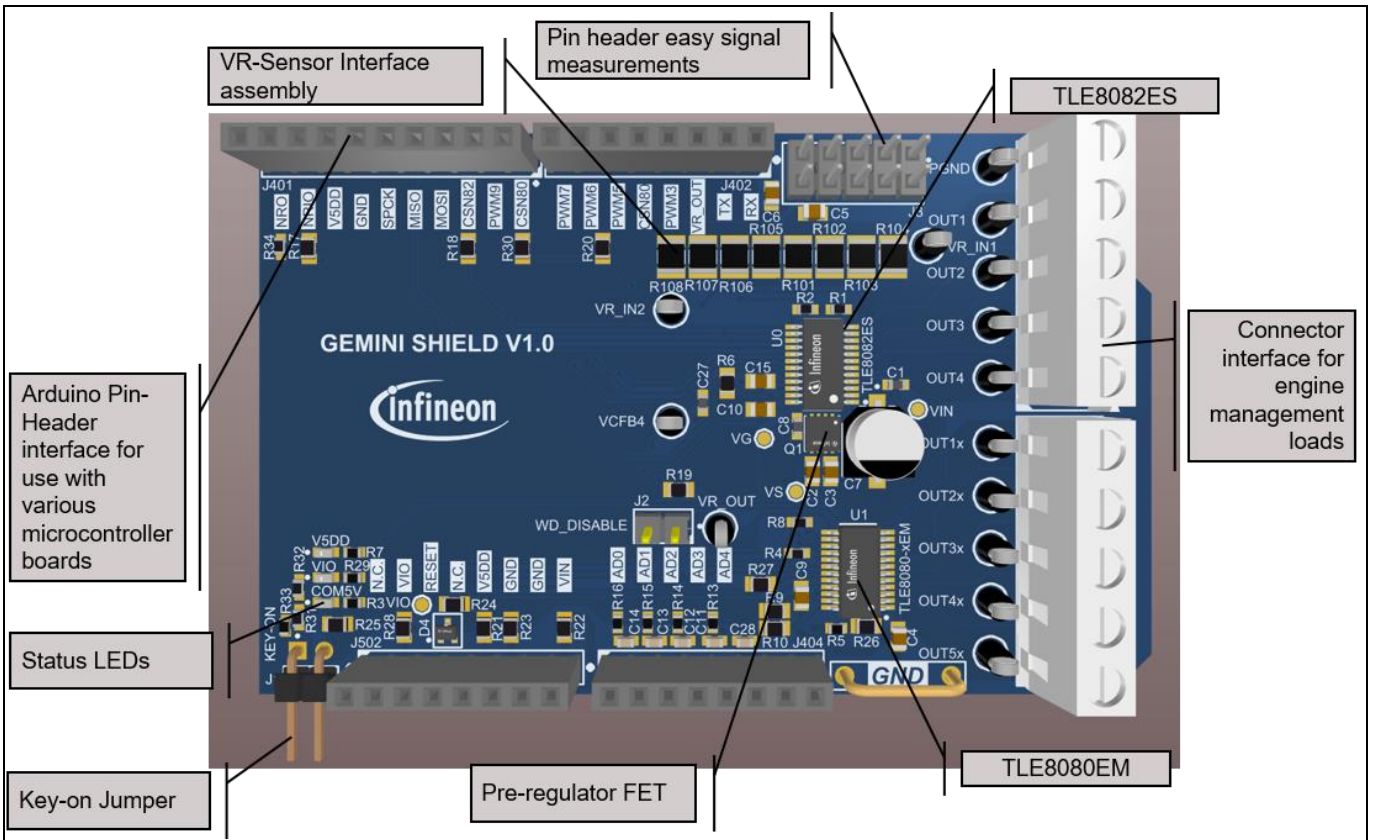

**Figure 1 Functional component blocks on the Evaluation PCB**

The Evaluation board provides an Arduino pinout form factor. It can be controlled with every Arduino compatible microcontroller board. Infineon provides a control software for two different microcontroller boards: XMC1100 Boot Kit and Aurix ShieldBuddy TC275. Figure 2 and Figure 3 show the hardware setup of both variants.

### 1.1 XMC Hardware setup

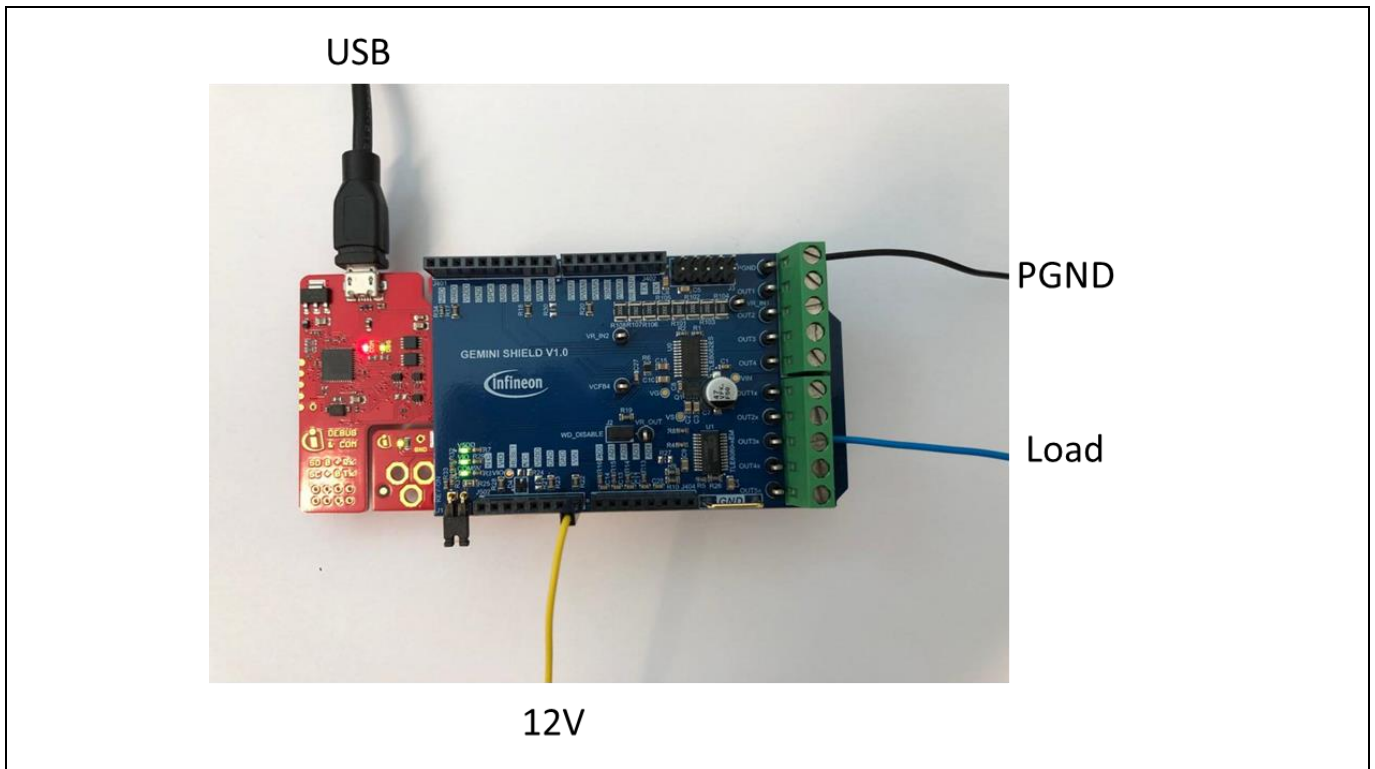

Figure 2 Illustration of XMC Hardware setup

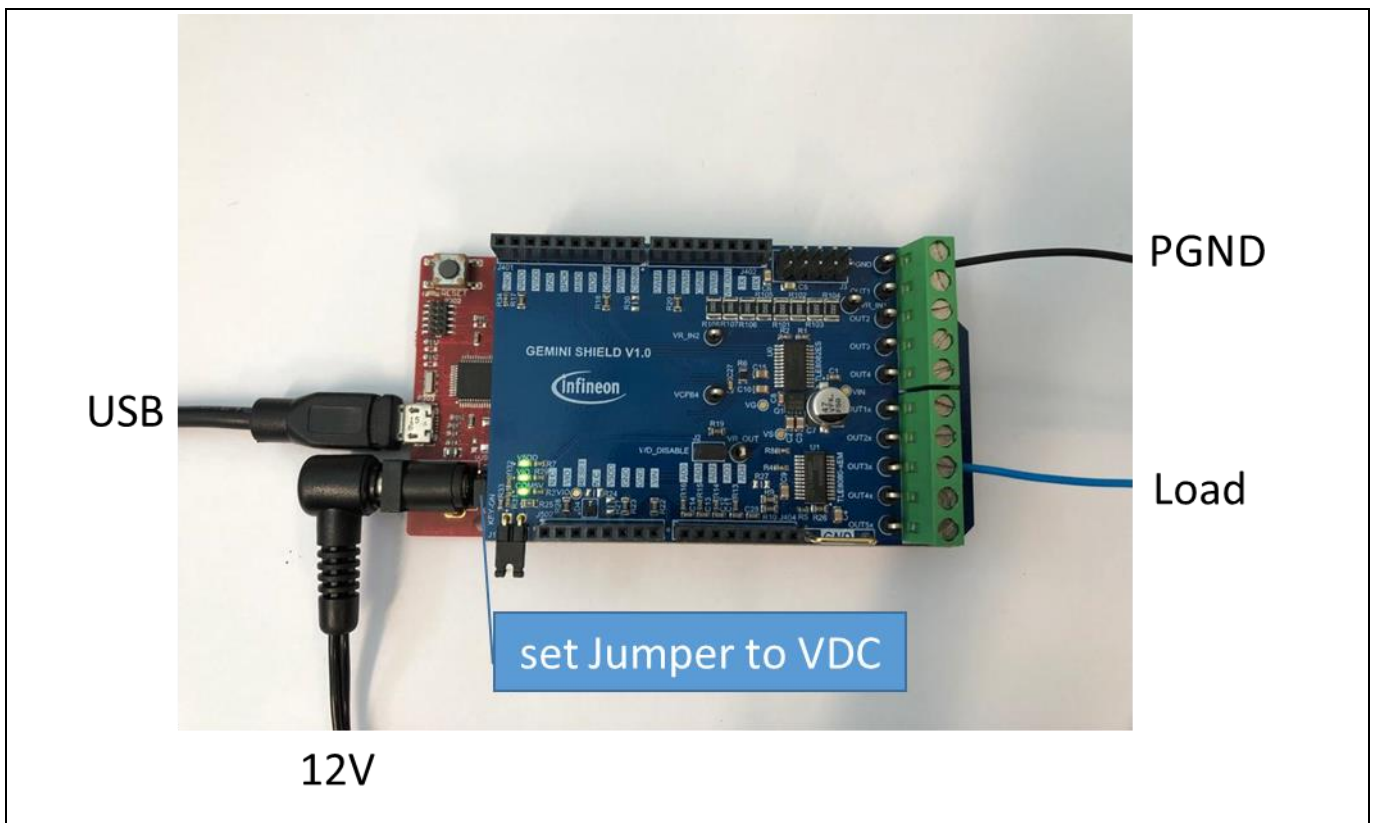
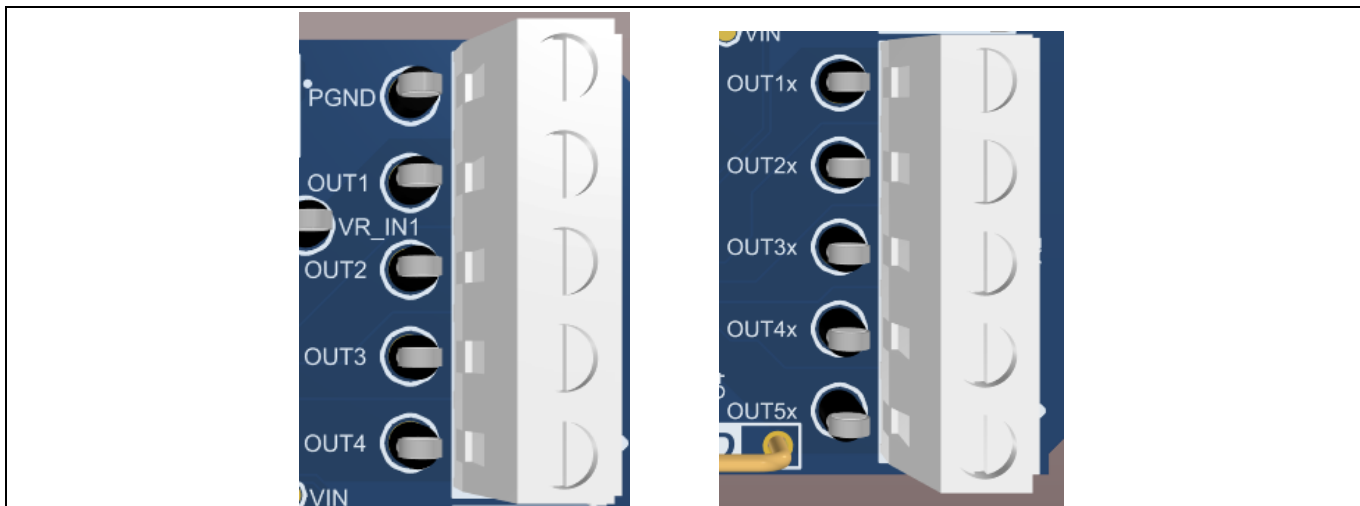

Figure 3 Illustration of Aurix Shield Buddy Hardware setup

### 1.1.1 Output connectors

The Evaluation board provides two power connectors to drive inductive and/or resistive loads with TLE8080EM and TLE8082ES



**Figure 4** TLE8082ES - Output Connector X1 (left), TLE8080EM Output connector X2 (right)

**Table 1** TLE8082ES - Output connector X1

Output of TLE8082ES	Pin no.	Description
PGND	X1-5	Power ground signal – optional use if GND ≠ PGND (open R23) or use as additional GND connection
OUT1	X1-4	Status of output stage 1 of TLE8082ES
OUT2	X1-3	Status of output stage 2 of TLE8082ES
OUT3	X1-2	Status of output stage 3 of TLE8082ES
OUT4	X1-1	Status of output stage 4 of TLE8082ES

**Table 2** TLE8080EM - Output connector X2

Output of TLE8082ES	Pin no.	Description
OUT1x	X2-5	Status of output stage 1 of TLE8082EM
OUT2x	X2-4	Status of output stage 2 of TLE8082EM
OUT3x	X2-3	Status of output stage 3 of TLE8082EM
OUT4x	X2-2	Status of output stage 4 of TLE8082EM
OUT5x	X2-1	Status of output stage 5 of TLE8082EM

### 1.1.2 Connector Interface for Arduino

The Connector placement of the Evaluation PCB is compliant with the Arduino form-factor. The pinouts are listed below.

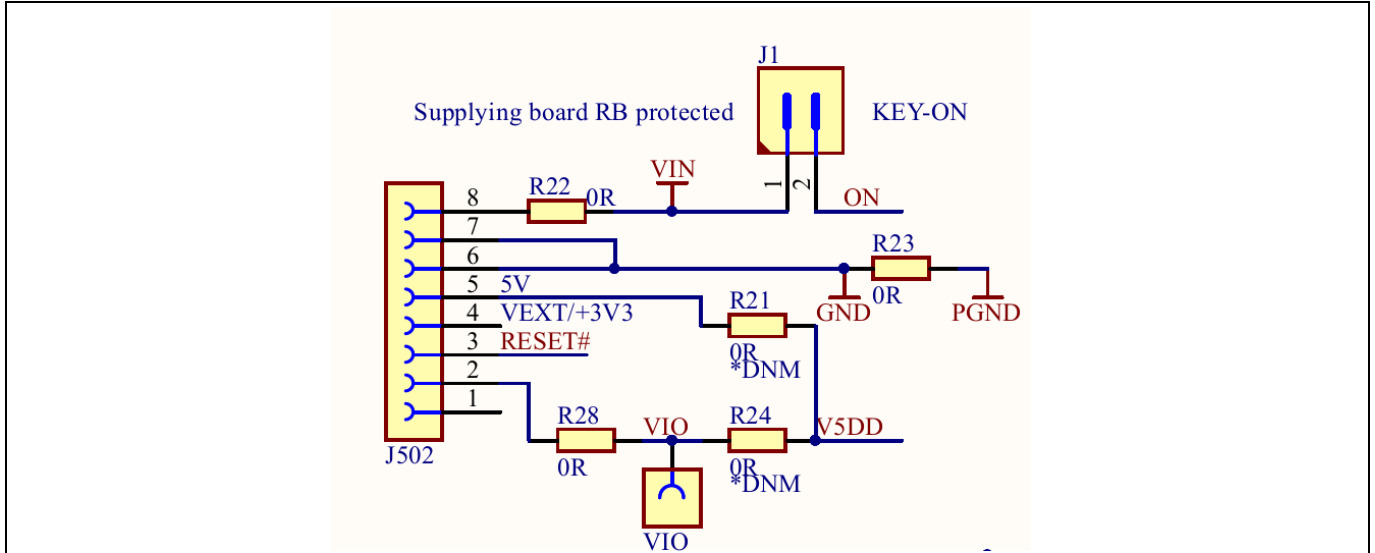

**Figure 5 Power Connector J502**

**Table 3 Power supply Connector J502**

Pin no.	Arudino Signal Name	Evaluation PCB Signal Name	Description
1	-	-	-
2	IOREF	VIO	Communication supply level (SPI)
3	RESET	RESET#	External reset signal (low active) connected to NRIO. Reset of TLE8082ES and TLE8080EM (if R27 jumper assembled).
4	3.3V	+3.3V	3V3 volt supply – not used
5	5V	+5V	5V volt supply – not used
6	GND	GND	Ground
7	GND	GND	Ground
8	VIN	VBAT	Voltage Level (usually 12V) applied to VS and KEY (if J1 is closed)

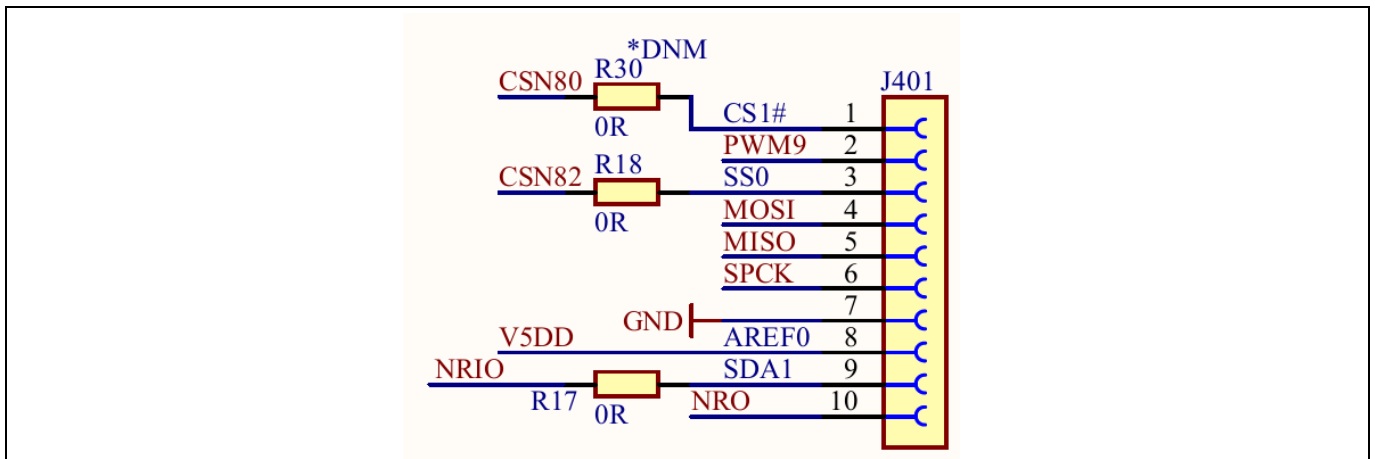

**Figure 6** Communication Interface Connector J401

**Table 4** Communication Interface Connector J401

Pin no.	Arudino Signal Name	Evaluation PCB Signal Name	Description
1	IO8	CS1#	SPI Chipselect signal for multiply Evaluation PCB use. Note: R30 must be assembled.
2	IO9	IN1 (TLE8082EM)	PWM input connected to TLE8082EM IN1
3	IO10	CS0#	SPI Chipselect signal for TLE8082ES
4	IO11	MOSI	SPI Master Out Slave In
5	IO12	MISO	SPI Master In Slave Out
6	IO13	SCLK	SPI Clock
7	GND	GND	Ground
8	AREF	AREF	Analog reference – 5V by TLE8080EM
9	SDA	NRIO	NRIO signal to microcontroller
10	SCL	NRO	NRO signal to microcontroller

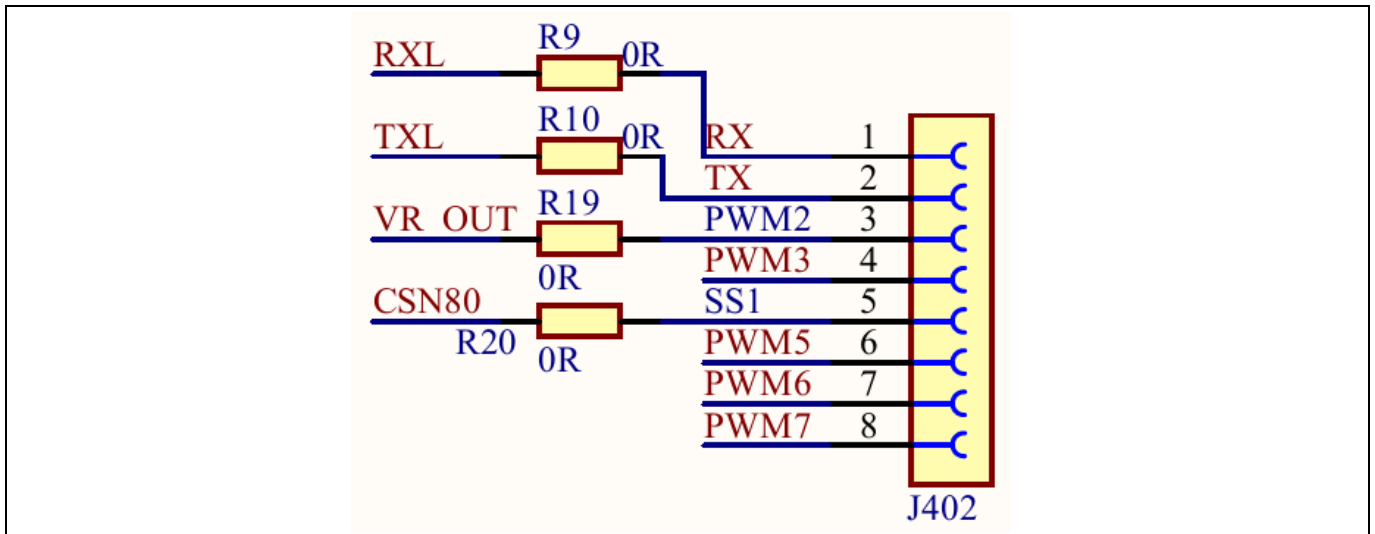

**Figure 7 Digital IO Connector J402**

**Table 5 Digital IO Connector J402**

Pin no.	Arudino Signal Name	Evaluation PCB Signal Name	Description
1	I00	RX	UART Receive – not used – can be connected to COM5V via J3
2	I01	TX	UART Transmit – not used – can be connected to V5DD via J3
3	I02	VR_OUT	TLE8080EM VR output signal – can be disconnected via R19
4	I03	PWM3	TLE8080EM IN3
5	I04	CSN80	SPI Chipselect signal for TLE8080EM
6	I05	PWM5	TLE8082ES IN1
7	I06	PWM6	TLE8082ES IN23
8	I07	PWM7	TLE8082ES IN4

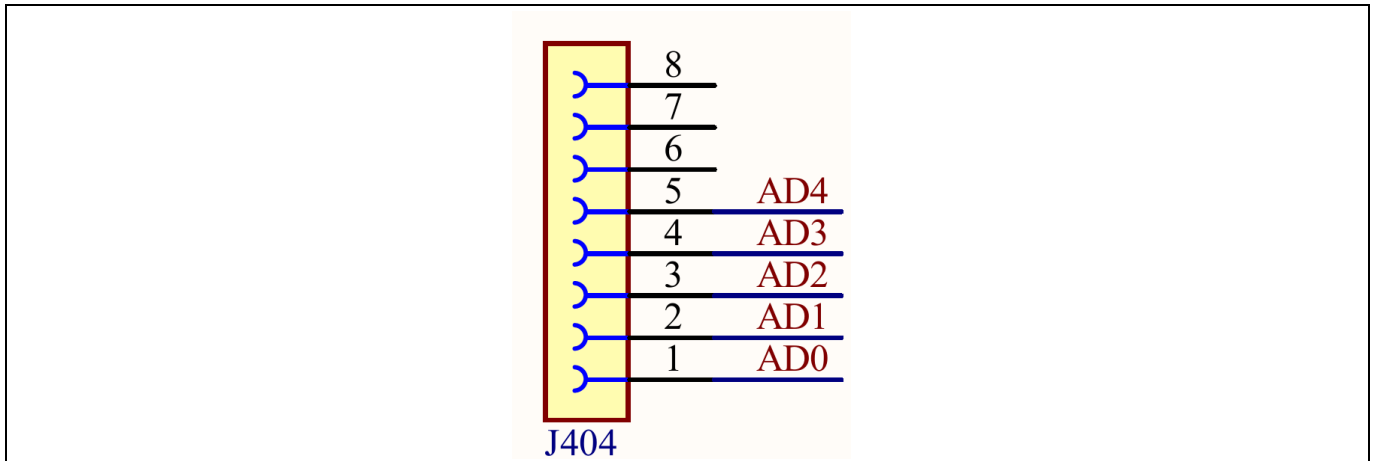

**Figure 8** Analog Connector J404

**Table 6** Analog Connector J404

Pin no.	Arudino Signal Name	Evaluation PCB Signal Name	Description
1	AD0	COM5V	Voltage of TLE8082ES COM5V
2	AD1	T5V	Voltage of TLE8082ES T5V
3	AD2	V5DD	Voltage of TLE8082ES V5DD
4	AD3	CFB4 (current sense)	Voltage of TLE8082ES CFB pin for current feedback
5	AD4	KEY-ON	Voltage of TLE8082ES KEY pin for on/off detection
6	AD5	-	Not connected
7	-	-	-
8	-	-	-

### 1.1.3 Measurement and Jumper Options

On the Evaluation PCB are various configuration options available for individual measurements or setup options, respectively.

The pin header J3 is intended to make signal available to ease the measurement with oscilloscope probes.

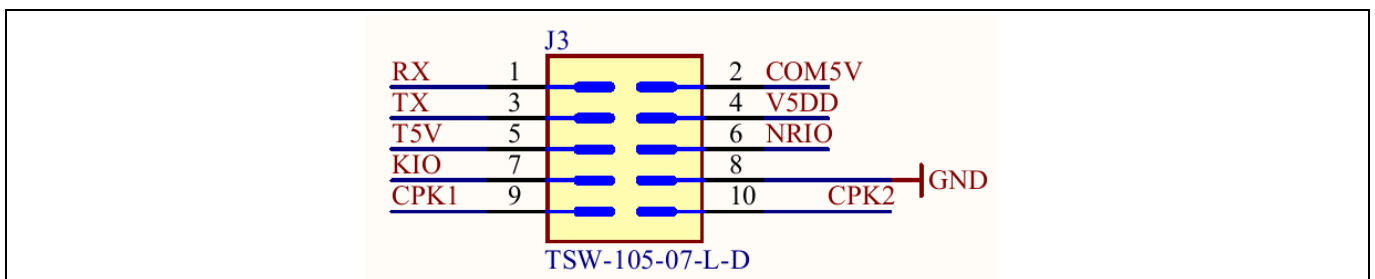



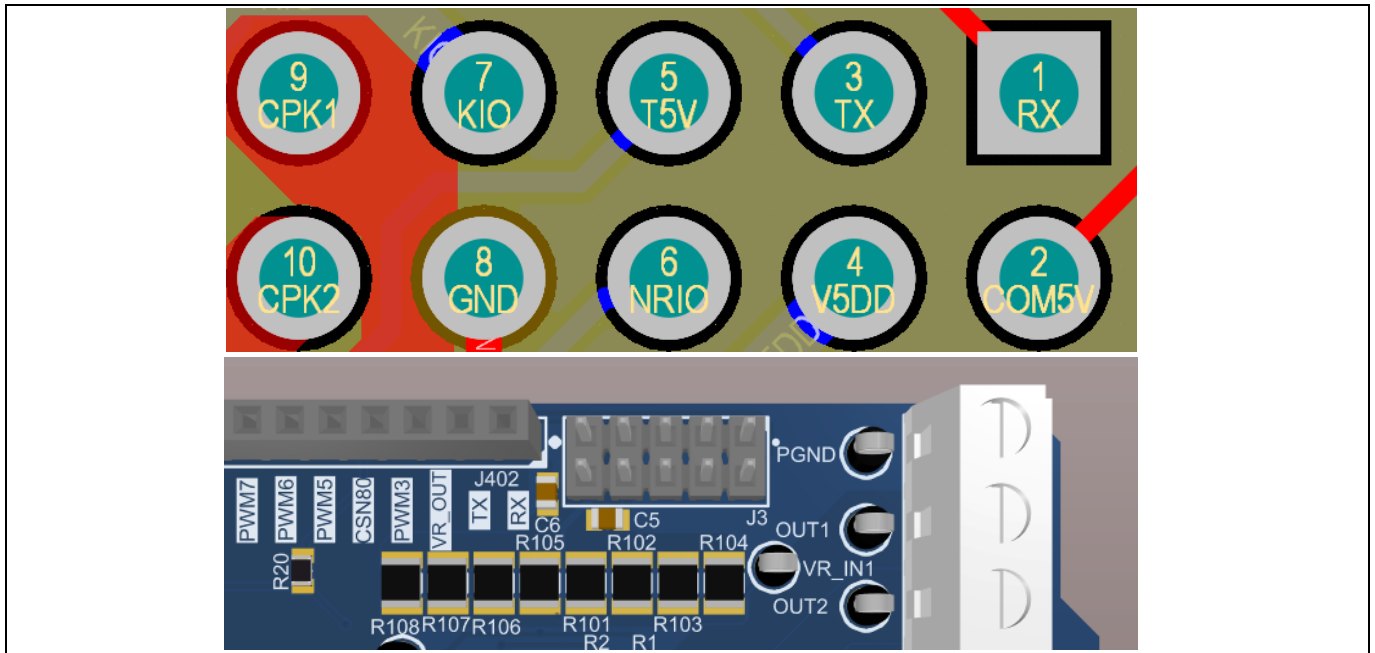

**Figure 9 Measurement signal at J3**

Various test point allow an easy measurement of signals during evaluation. Following table describes the signals that can be measured via test points.

**Table 7 Measurement points**

Measurement signal	Measurement Designation	Description
VR sensor interface of TLE8082EMES	VR_IN1	VR sensor signal 1
	VR_IN2	VR sensor signal 1
	VR_OUT	Logic output signal swichted according to to input voltage difference (VR_IN1 – VR_IN2)
Current sense of TLE8082ESEM	VCFB4	Voltage level proportional to current through output stage 4 of TLE8082ES
Voltages	VIN	Input/Battery Voltage, usually 12 V
	VG	Gate Voltage for Pre-regulator MOS-FET, usually 8 V
	VS	Output voltage of Pre-regulator MOS-FET, usually 6 V
	VIO	Voltage level for SPI output buffer, usually 5 V

The jumper options are described in the table below.

**Table 8 Jumper Options**

<b>Jumper</b>	<b>Jumper Designation</b>	<b>Description</b>
KEY on signal	J1	Close to wake up TLE8082ES
Watchdog disable	J2	Close to disable watchdog function of TLE8080EM
Supply to external	R21 (default open)	Close to provide 5V to external via J502-5
	R24 (default open)	Close to provide 5V to external via J502-2 (VIO signal)
Reset options	R27 (default open)	Connect TLE8082ES NRIO and TLE8080EM NRO to control TLE8082ES reset with TLE8080EM
Arduino signals	R17, R9, R10, R19, R20, R18, R30	Open/close for use of Arduino specific signal for other purposes

### 1.1.4 LEDs

The Evaluation board provides LEDs to indicate the voltage levels of TLE8082ES. The meaning of the status LEDs is described below.

**Table 9 LED description**

<b>LED designation</b>	<b>TLE8082ES Pin designation</b>	<b>Description</b>
V5DD	V5DD	Glow if 5V of V5DD is active
VIO	VIO	Glow if VIO voltage is active
COM5V	COM5V	Glow if COM5V voltage is active

## 1.2 Schematic and Layout

This chapter provides the schematics and layout of the Evaluation board at a glance.

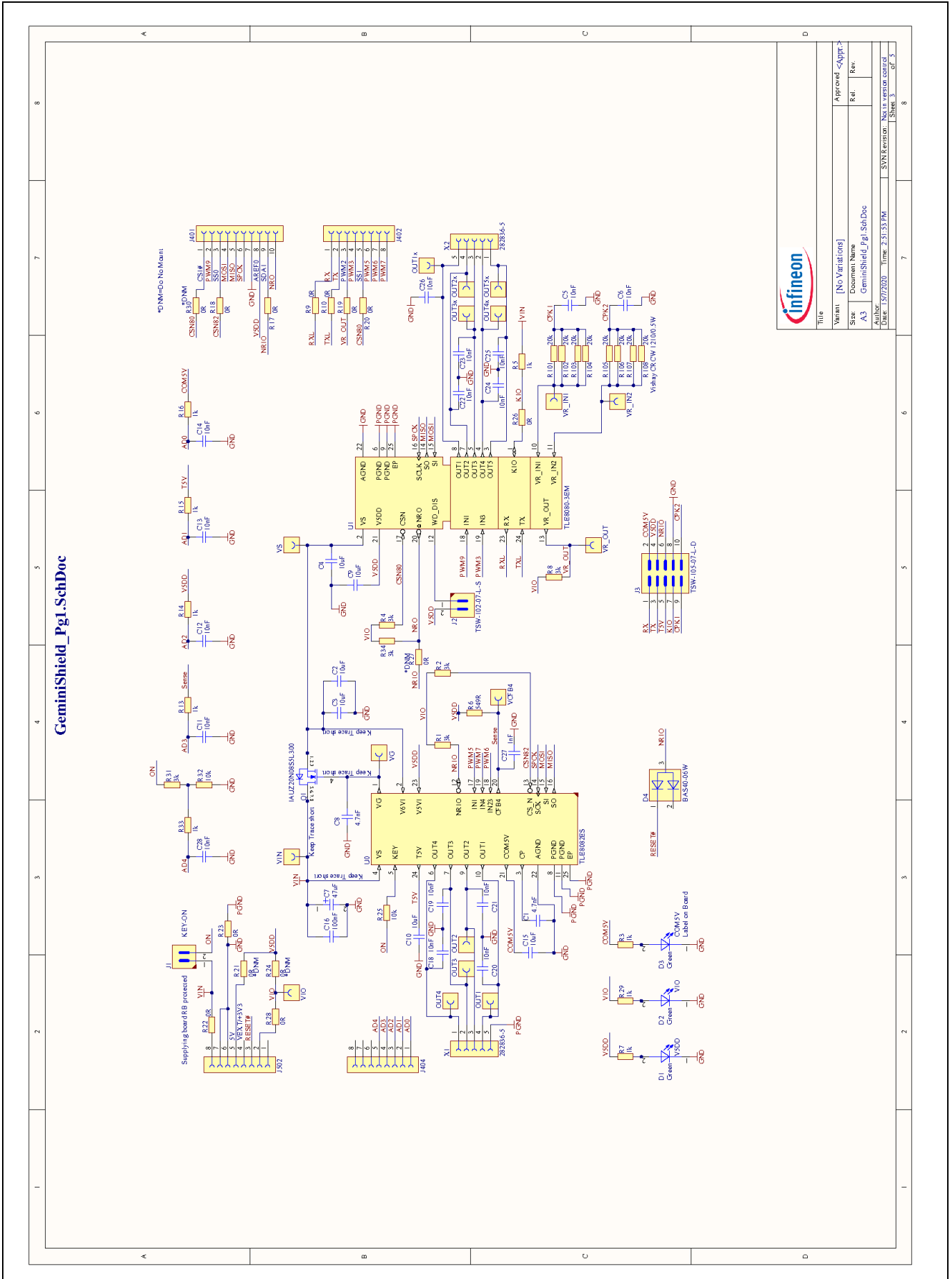

Title	
Version	[No Variations]
Size	Document Name
A3	GeminiShield_Pgl.SchDoc
Author	
Date	19/07/2020 Time: 2:31:53 PM
SYPR/Revision	Not in version control
	Sheet 3 of 5

Figure 10 Schematic of the Evaluation Board

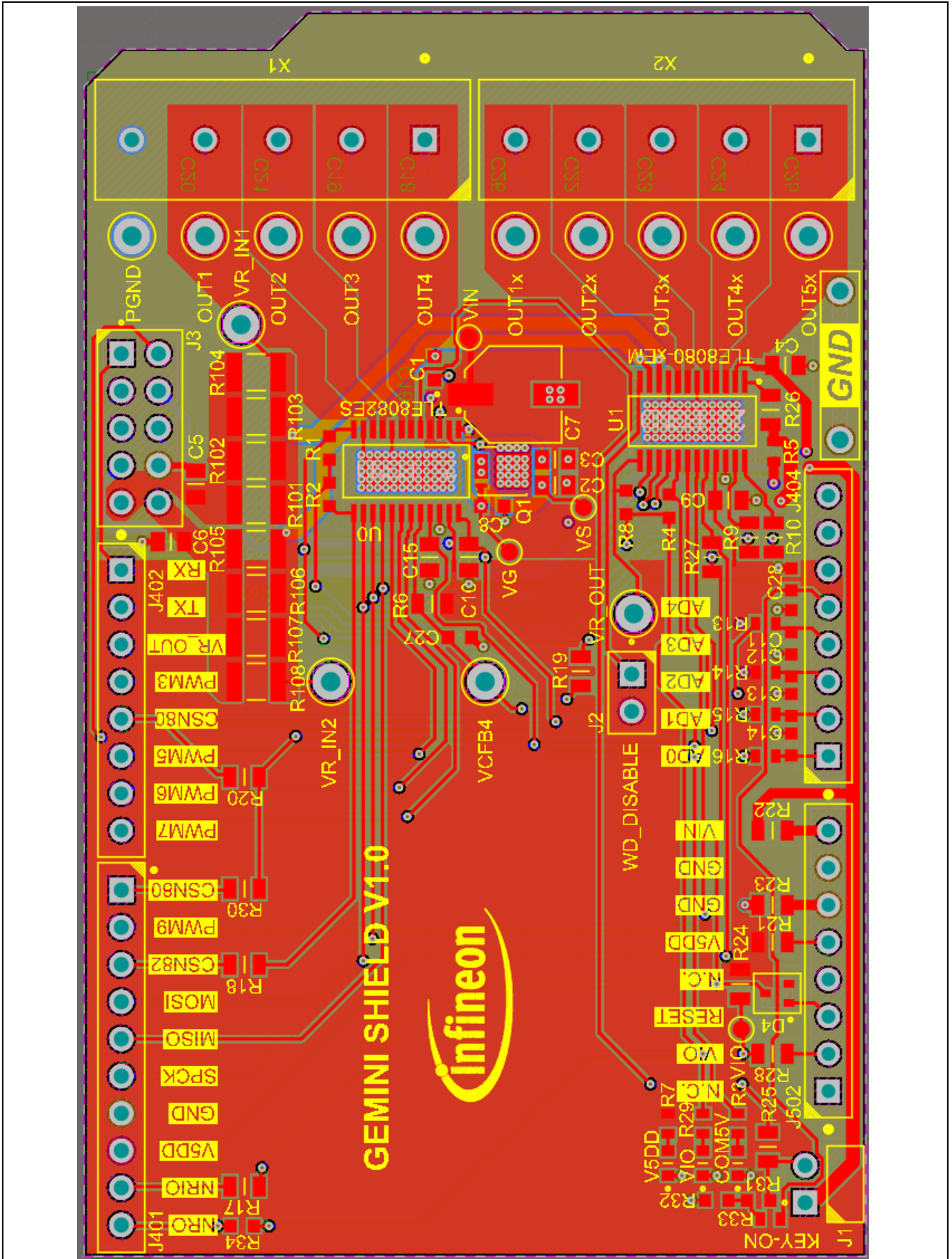

Figure 11 Layout Evaluation-PCB

## 2 Software

The TLE8082EM2+TLE8082EM Evaluation board control software is available for two different Infineon microcontroller boards:

- XMC setup for the use of e.g. XMC1100 Boot kit
- Aurix ShieldBuddy: TC275 TriCore microcontroller board supporting the Arduino form factor

Both setup types require the use of an appropriate Arduino IDE such as the [Standard Arduino IDE](#) or Visual Studio including [PlatformIO](#). This manual focuses on the Standard Arduino IDE.

Each setup requires an according software environment to be installed on your machine. Depending on the setup you are using please follow the steps described in “2.1 - XMC setup” or “2.2 - Aurix ShieldBuddy TC275”, respectively.

### 2.1 XMC setup

The use of the XMC board setup requires the installation of the XMC-for-Arduino board information. Please follow the instruction at <https://github.com/Infineon/XMC-for-Arduino> to integrate the XMC board into your Arduino IDE. The Arduino Script for the XMC setup requires the use of the “Every Timer” Library. Please install it via the Arduino IDE Library Manager.

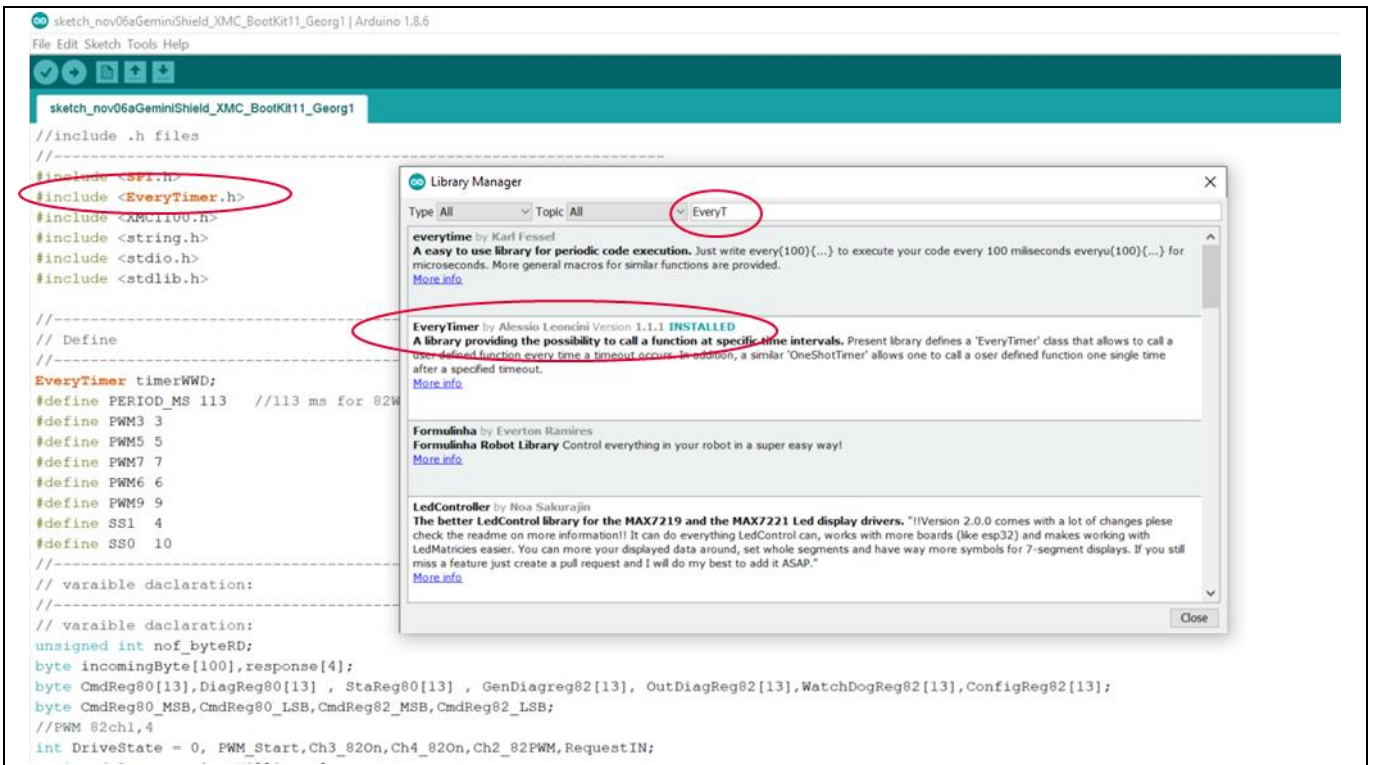

Figure 12 Install the required EveryTimer Library

## 2.2 Aurix ShieldBuddy TC275

The Aurix ShieldBuddy board requires the use of the “FreeEntryToolchain” to compile the Arduino Sketch correctly. If not done already, please install the [FreeEntryToolchain](#) to use the ShieldBuddy. Additionally, the Board information must be integrated in the used Arduino IDE. Therefore, please download and install the [ShieldBuddyMulticoreIDE](#) (Password: ShieldBuddy). Further information can be found in the [getting started guide for ShieldBuddy](#).

## 2.3 Flash Arduino script

Once the software environment has been successfully installed, please follow the below listed steps in the Standard Arduino IDE:

- Select the microcontroller board you are using under Tools → Board.
- Open the appropriate Arduino script (provided by Infineon) in the Arduino IDE via File → open.
- Connect the microcontroller board to the PC via USB and select the correct COM port in the Arduino IDE under Tools → Port
- Open the Serial Monitor in the Arduino IDE under Tools → Serial Monitor and select the correct baud rate in the lower right corner of the Serial Monitor
  - XMC setup: 230400 Baud
  - ShieldBuddy: 115200 Baud
- Flash the script onto the microcontroller via Sketch → Upload
- If the ShieldBuddy is used, please press the Reset button on the board

The starting menu in the Serial Monitor pops up after successful flashing of the Arduino script. Figure 13 shows the start menu of the ShieldBuddy setup and Figure 14 shows the start menu of the XMC setup.

The commands that can be sent to the Evalboard follow a structure. First, the addressed device is specified (80: TLE8080EM, 82: TLE8082ES), followed directly by the actual command e.g. ch1 to switch the state of ch1. After a space the intended action is specified e.g. “0” to disable ch1. The main menu is clustered into four main command sections:

- PWM menu: control of TLE8082EM CH1/3 and TLE8082ES CH1/3 with specified PWM signal
- SPI ON/OFF menu: on/off control of TLE8082EM CH2/4/5 and TLE8082ES CH2/4 via SPI
- VRS menu: configuration of TLE8082EM VRS interface
- COM5V/Tracker/AfterRun menu: control of voltage supply domains, afterrun option and diagnosis of all channels

Please consider that the XMC software requires different commands than the ShieldBuddy software. The command nomenclature for the XMC setup is given under the section “Key-in”.

```

COM5V 82com: disabled ASC 115200 Init done.
Please choose Newline as end marker!

Welcome to ShieldBuddy_GeminiShield Menu
-----

PWM menu          [Frequency:10,20...80HZ, Duty:10,20...90%]
-----
80ch1 10 90      [This means TLE8080_IN1 PWM9 Frequency: 10HZ , Duty:90%]
80ch3 20 80      [This means TLE8080_IN3 PWM3 Frequency: 20HZ , Duty:80%]
82ch1 30 70      [This means TLE8082_IN1 PWM5 Frequency: 30HZ , Duty:70%]
82ch3 50 50      [This means TLE8082_IN3 PWM6 Frequency: 50HZ , Duty:50%]

SPI ON/OFF Menu
-----
80ch2 1/0        [ON/OFF]
80ch4 1/0        [ON/OFF]
80ch5 1/0        [ON/OFF]
82ch2 1/0        [ON/OFF]
82ch4 1/0        [IN4 ON/OFF]

VRS Menu
-----
80vr1 0/1/2/3    [Rload 75kohm/4.5kohm/2.2kohm/1.2kohm]
80vrt 0/1/2/3    [Threshold -50mV/-100mV/-500mv/-1V]

COM5V/Tracker/AferRun Menu
-----
82com 1/0        [COM5V ON/OFF]
82trk 1/0        [Tracker output T5 ON/OFF]
82are 1/0        [AfterRun Enable bit ON/OFF]
all diag         [TLE8080/82 diagnostic requests]

Enter command:
 Autoscroll  Show timestamp
Newline 115200 baud Clear output
    
```

**Figure 13 Start menu for Evalboard control via Serial Terminal - ShieldBuddy**

```

Welcome to XMC11BtKit_GeminiShield Menu

SPI Menu      Key-in
80ch2 1/0    s 0/1      [ON/OFF]
80ch4 1/0    s 0/1      [ON/OFF]
80ch5 1/0    s 0/1      [ON/OFF]
82ch3 1/0    s 0/1      [ON/OFF]
82ch4 1/0    s 0/1      [IN4 ON/OFF]

PWM menu      Key-in      [Frequency steps 1000,2000...9000rpm[max], Duty steps 10,20...90%[max]]
80ch1 10 90   119        [This means TLE8080_IN1 PWM9 Frequency: 1000rpm , Duty:90%]
82ch2 1/0    2 1/0      [ON/OFF for TLE8082_IN2/3[PWM6]Fixed Freq:10HZ,Fixed Duty:50%]
80ch3 20 80   328        [This means TLE8080_IN3 PWM3 Frequency: 2000rpm , Duty:80%]
82ch1 1/0    4 1/0      [ON/OFF for TLE8082_IN1[PWM5]Fixed Freq:10HZ,Fixed Duty:50%]

VRS Menu      Key-in
80vr1 0..3    vr0/1/2/3  [Rload 75kohm/4.5kohm/2.2kohm/1.2kohm]
80vrt 0..3    vt0/1/2/3  [Threshold -50mV/-100mV/-500mv/-1V]

Others Menu    Key-in
82com 1/0     co1/0      [COM5V Enable/Disable]
82trk 1/0     tr1/0      [Tracker T5V Enable/Disable]

 Autoscroll  Show timestamp
Newline 230400 baud Clear output
    
```

**Figure 14 Start menu for Evalboard control via Serial Terminal - XMC**

### 3 Application Example: Current Measurement with TLE8082 CFB

The current feedback pin (CFB4) of TLE8082ES provides a pull down current which is directly proportional to the output current of channel 4. This information can be used e.g. to estimate the temperature of the applied output stage load (O2 heater). The evaluation board reads back the supply voltage VIN. The resistance of the O2 heater can be calculated by using Ohms law. Figure 15 gives an overview how the temperature of the O2 heater load can be estimated.

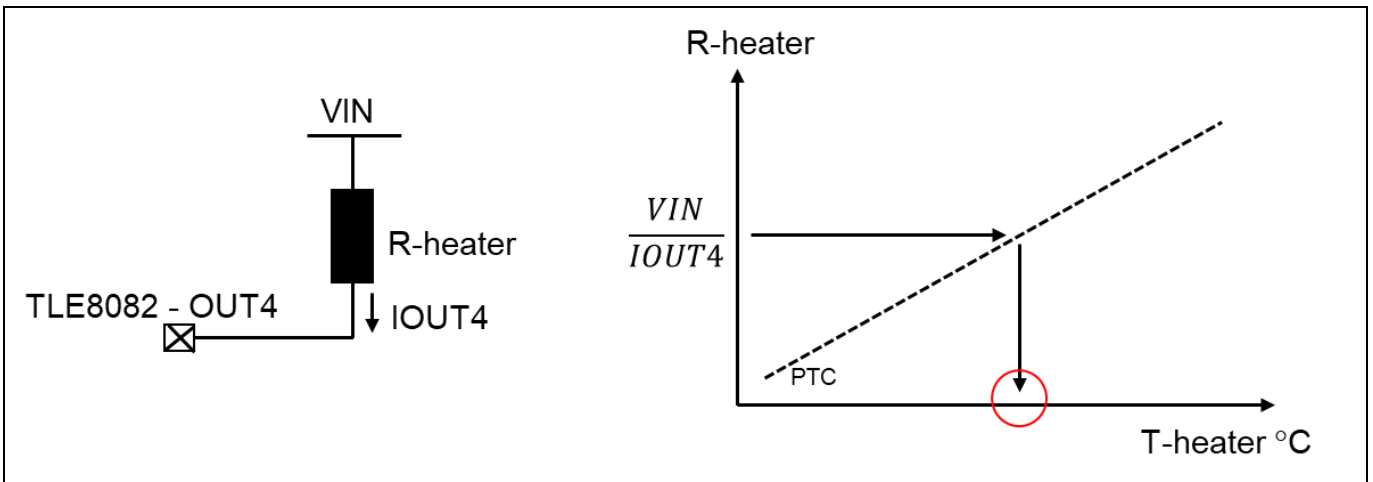

Figure 15 Overview of O2 heater temperature estimation

The voltage at CFB4 is pulled up to V5DD over R6. The resistance value of R6 can be individually adapted, if required. The reference voltage VREF used for the microcontroller ADC can be modified in the Arduino software sketch. Figure 16 gives an overview on the tune-able values.

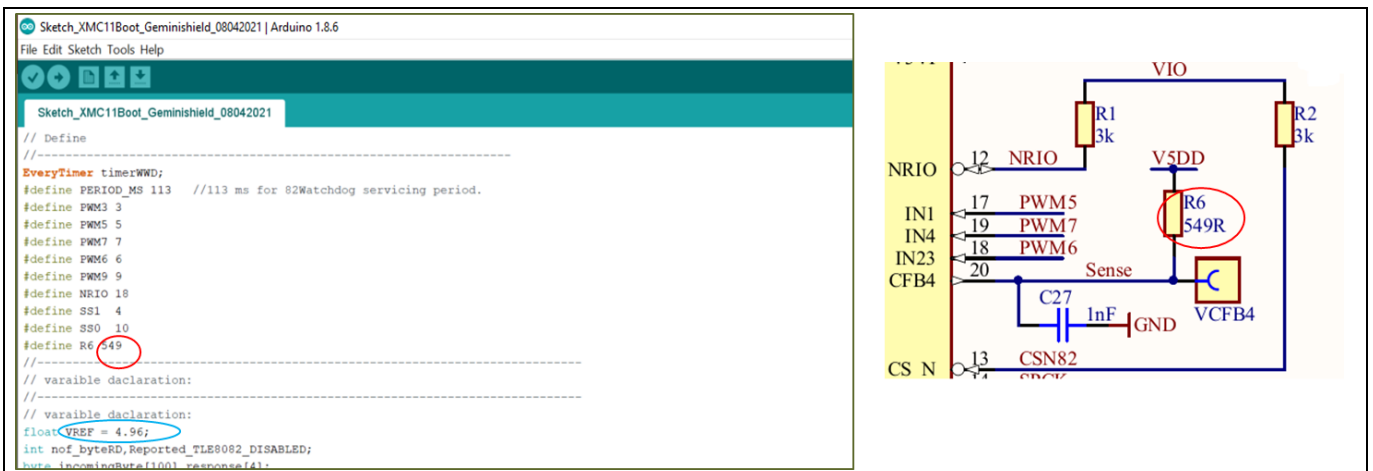

Figure 16 ADC measurement setup can be modified to individual needs



## Revision history

### Major changes since the last revision

Page or Reference	Description of change
V1.0	Initial release

#### Trademarks of Infineon Technologies AG

$\mu$ HVIC™,  $\mu$ IPM™,  $\mu$ PFC™, AU-ConvertIR™, AURIX™, C166™, CanPAK™, CIPOS™, CIPURSE™, CoolDP™, CoolGaN™, COOLiR™, CoolMOS™, CoolSET™, CoolSiC™, DAVE™, DI-POL™, DirectFET™, DrBlade™, EasyPIM™, EconoBRIDGE™, EconoDUAL™, EconoPACK™, EconoPIM™, EiceDRIVER™, eupec™, FCOS™, GaNpowIR™, HEXFET™, HITFET™, HybridPACK™, iMOTION™, IRAM™, ISOFACE™, IsoPACK™, LEDrivr™, LITIX™, MIPAQ™, ModSTACK™, my-d™, NovalithIC™, OPTIGA™, OptiMOS™, ORIGA™, PowIRaudio™, PowIRstage™, PrimePACK™, PrimeSTACK™, PROFET™, PRO-SIL™, RASIC™, REAL3™, SmartLEWIS™, SOLID FLASH™, SPOC™, StrongIRFET™, SupIRBuck™, TEMPFET™, TRENCHSTOP™, TriCore™, UHVIC™, XHP™, XMC™

Trademarks updated November 2015

#### Other Trademarks

All referenced product or service names and trademarks are the property of their respective owners.

**Edition 2021-04-28**

**Published by**

**Infineon Technologies AG**

**81726 München, Germany**

**© 2021 Infineon Technologies AG.**

**All Rights Reserved.**

**Do you have a question about this document?**

**Email: [erratum@infineon.com](mailto:erratum@infineon.com)**

**Document reference**

**v1.0**

#### IMPORTANT NOTICE

The information given in this document shall in no event be regarded as a guarantee of conditions or characteristics ("Beschaffenheitsgarantie").

With respect to any examples, hints or any typical values stated herein and/or any information regarding the application of the product, Infineon Technologies hereby disclaims any and all warranties and liabilities of any kind, including without limitation warranties of non-infringement of intellectual property rights of any third party.

In addition, any information given in this document is subject to customer's compliance with its obligations stated in this document and any applicable legal requirements, norms and standards concerning customer's products and any use of the product of Infineon Technologies in customer's applications.

The data contained in this document is exclusively intended for technically trained staff. It is the responsibility of customer's technical departments to evaluate the suitability of the product for the intended application and the completeness of the product information given in this document with respect to such application.

For further information on the product, technology, delivery terms and conditions and prices please contact your nearest Infineon Technologies office ([www.infineon.com](http://www.infineon.com)).

#### WARNINGS

Due to technical requirements products may contain dangerous substances. For information on the types in question please contact your nearest Infineon Technologies office.

Except as otherwise explicitly approved by Infineon Technologies in a written document signed by authorized representatives of Infineon Technologies, Infineon Technologies' products may not be used in any applications where a failure of the product or any consequences of the use thereof can reasonably be expected to result in personal injury.