

APPROVAL SHEET

WK12K, WK08K, WK06K, WK04K, WK02K

$\pm 1.0\%$, $\pm 0.5\%$

Thick Film TC50/TC100

High Precision Thick Film chip resistors

Size 1206, 0805, 0603, 0402, 0201

FEATURE

1. SMD Thick film resistor
2. High reliability and stability
3. High performance of TCR: 50 ppm/K
4. High precision
5. RoHS compliant & Lead free

APPLICATION

- Medical equipment
- Measuring instrument
- Communication device
- Computer
- Printer

DESCRIPTION

The resistors are constructed in a high grade ceramic body (aluminum oxide). Internal metal electrodes are added at each end and connected by a resistive layer that is applied to the top surface of the substrate. The composition of the resistive layer is adjusted to give the approximate resistance required and the value is trimmed to nominated value within tolerance which controlled by laser trimming of this resistive layer.

The resistive layer is covered with a protective coat. Finally, the two external end terminations are added. For environmental soldering issue, the outer layer of these end terminations is a Lead-free solder .

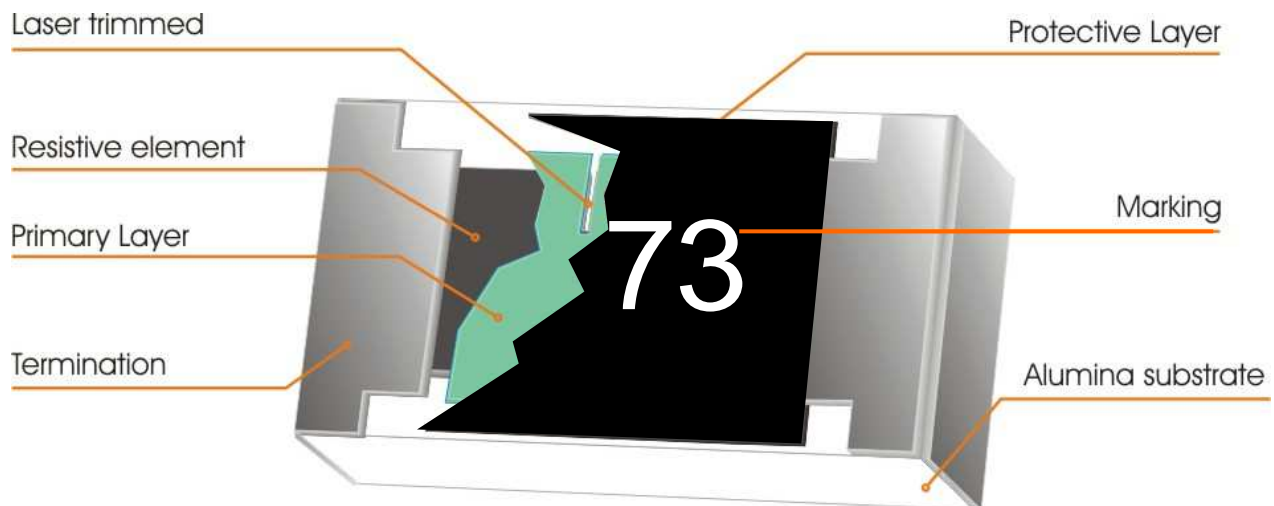

Fig 1. Construction of Chip-R WKxxK

QUICK REFERENCE DATA

Item	General Specification				
Series No.	WK12K	WK08K	WK06K	WK04K	WK02K
Size code	1206 (3216)	0805 (2012)	0603 (1608)	0402 (1005)	0201 (0603)
Resistance Tolerance	±1.0%, ±0.5% (E24 +E96)				
Resistance Range/ TCR (ppm/°C)	3.3 ~ 9.76Ω: 50ppm 10Ω ~ 4.7MΩ: 50ppm-	3.3 ~ 9.76Ω: 50ppm 10Ω ~ 3.3MΩ: 50ppm	3.3 ~ 9.76Ω: 100ppm 10 ~ 97.6Ω: 100ppm 100Ω ~ 1MΩ: 50ppm 1.02~3.3MΩ: 100ppm	10 ~ 97.6Ω: 100ppm 100Ω ~ 1MΩ: 50ppm 1.02~3.3MΩ: 100ppm	51 ~ 976Ω: 100ppm 1KΩ ~ 1MΩ: 50ppm
Max. dissipation at T _{amb} =70°C	1/4W	1/8W	1/10W	1/16W	1/20W
Max. Operation Voltage (DC or RMS)	200V	150V	50V	50V	25V
Max. Overload Voltage (DC or RMS)	400V	300V	100V	100V	50V
Climatic category	55/125/56				

Note :

- This is the maximum voltage that may be continuously supplied to the resistor element, see "IEC publication 60115-8"
- Max. Operation Voltage : So called RCWV (Rated Continuous Working Voltage) is determined by

$$RCWV = \sqrt{\text{Rated Power} \times \text{Resistance Value}}$$
 or Max. RCWV listed above, whichever is lower.
- Green color overcoat.

DIMENSION (unit : mm)

Type	WK12K	WK08K	WK06K	WK04K	WK02K
L	3.20 ± 0.15	2.00 ± 0.10	1.60 ± 0.10	1.00 ± 0.05	0.60 ± 0.03
W	1.60 ± 0.15	1.25 ± 0.10	0.80 +0.15/-0.05	0.50 ± 0.05	0.30 ± 0.03
t	0.60 ± 0.10	0.60 ± 0.10	0.45 ± 0.10	0.35 ± 0.05	0.23 ± 0.03
A	0.50 ± 0.25	0.40 ± 0.20	0.25 ± 0.10	0.20 ± 0.10	0.10 ± 0.05
B	0.50 ± 0.25	0.40 ± 0.20	0.30 ± 0.10	0.25 +0.05/-0.10	0.15 ± 0.05

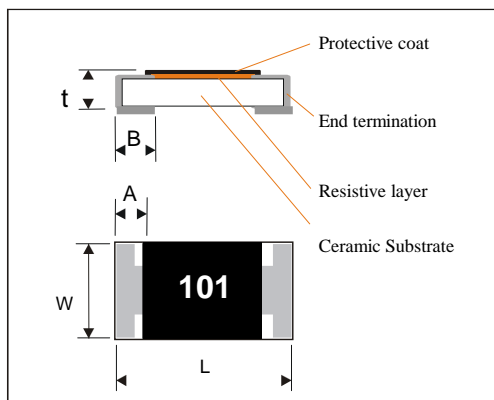

MARKING

Each resistor is marked with 3 digits for E24 and 4 digits for E96 on the protective coating to designate the nominal resistance value of E24 and E96.

0603 size has only marking with 3 digits for E24 and no marking for E96 !

0402/ 0201 size has no marking !

Example

RESISTANCE	100Ω	562KΩ	51.1Ω
MARKING	101	5623	51R1

- *No marking code for 0402/ 0201 size*

FUNCTIONAL DESCRIPTION

Product characterization

Standard values of nominal resistance are taken from the E24 & E96 series for resistors with a tolerance of $\pm 1.0\%$, $\pm 0.5\%$. The values of the E24/E96 series are in accordance with "IEC publication 60063".

Derating

The power that the resistor can dissipate depends on the operating temperature; see Fig.2

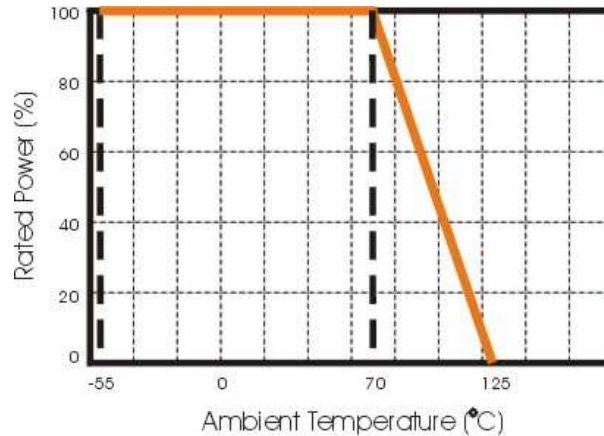

Figure 2. Maximum dissipation in percentage of rated power
As a function of the ambient temperature

MOUNTING

Due to their rectangular shapes and small tolerances, Surface Mountable Resistors are suitable for handling by automatic placement systems.

Chip placement can be on ceramic substrates and printed-circuit boards (PCBs).

Electrical connection to the circuit is by individual soldering condition.

The end terminations guarantee a reliable contact.

SOLDERING CONDITION

The robust construction of chip resistors allows them to be completely immersed in a solder bath of 260°C for 10 seconds. Therefore, it is possible to mount Surface Mount Resistors on one side of a PCB and other discrete components on the reverse (mixed PCBs).

Surface Mount Resistors are tested for solderability at 235°C during 2 seconds within lead-free solder bath. The test condition for no leaching is 260°C for 30 seconds. Typical examples of soldering processes that provide reliable joints without any damage are given in Fig 3.

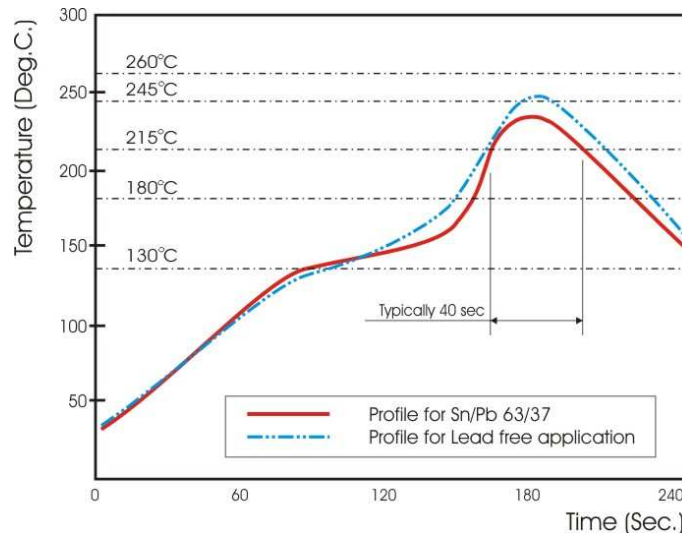

CATALOGUE NUMBERS

The resistors have a catalogue number starting with .

WK12	K	4990	D	T	L
Size code WK12: 1206 WK08: 0805 WK06: 0603 WK04: 0402 WK02: 0201	Type code TCR 50ppm/100ppm	Resistance code E24 +E96: First 3 significant digits represent resistance code and followed by number of zero. E24: 39R0=>39R0 820R =>8200 E96: 49R9 =>49R9 499R =>4990	Tolerance F : ±1.0% D : ±0.5%	Packaging code T : 7" Reeled A : 7" Reeled 15kpcs	Termination code L : lead free

1. Reeled tape packaging: 8mm width paper taping.

5,000pcs/reel for WK12, WK08, WK06;

10,000pcs/reel for WK04,

15,000pcs/reel for WK02

TEST AND REQUIREMENTS(JIS C 5201-1 : 1998)

TEST	PROCEDURE	REQUIREMENT
		Resistor
DC resistance Clause 4.5	DC resistance values measured <10Ω@0.1V, <100Ω@0.3V, <1KΩ@1.0V, <10KΩ@3V, <100KΩ@10V, <1MΩ@25V, <10MΩ@30V	Within the specified tolerance
Temperature Coefficient of Resistance(T.C.R) Clause 4.8	Natural resistance change per change in degree centigrade. $\frac{R_2 - R_1}{R_1(t_2 - t_1)} \times 10^6 \text{ (ppm/}^\circ\text{C)}$ R ₁ : Resistance at reference temperature R ₂ : Resistance at test temperature t ₁ : 20°C+5°C-1°C	Refer to "QUICK REFERENCE DATA"
Short time overload (S.T.O.L) Clause 4.13	Permanent resistance change after a 2 second application of a voltage 2.5 times RCWV or the maximum overload voltage specified in the above list, whichever is less.	ΔR/R max. ±(1.0%+0.05Ω)
Resistance to soldering heat(R.S.H) Clause 4.18	Un-mounted chips completely immersed for 10±1second in a SAC solder bath at 260°C±5°C	no visible damage Δ R/R max. ±(1.0%+0.05Ω)
Solderability Clause 4.17	Un-mounted chips completely immersed for 2±0.5 second in a SAC solder bath at 235°C±5°C	good tinning (>95% covered) no visible damage
Temperature cycling Clause 4.19	30 minutes at -55°C±3°C, 2~3 minutes at 20°C+5°C-1°C, 30 minutes at +125 °C±3°C, 2~3 minutes at 20°C+5°C-1°C, total 5 continuous cycles	no visible damage ΔR/R max. ±(1.0%+0.05Ω)
Load life (endurance) Clause 4.25	70±2°C, 1000 hours, loaded with RCWV or Vmax,1.5 hours on and 0.5 hours off	ΔR/R max. ±(5.0%+0.1Ω) No visual damage
Load life in Humidity Clause 4.24	1000 hours, at rated continuous working voltage in humidity chamber controller at 40°C±2°C and 95% relative humidity, 1.5hours on and 0.5 hours off	ΔR/R max. ±(5.0%+0.1Ω) No visual damage
Endurance at high temperature Clause 4.25	125°C, no load, 1000hours	ΔR/R max. ±(5.0%+0.1Ω) No visual damage
Bending strength Clause 4.33	Resistors mounted on a 90mm glass epoxy resin PCB(FR4); bending : 3 mm, once for 10 seconds.	ΔR/R max. ±(1.0%+0.05Ω)
Adhesion Clause 4.32	Pressurizing force: 5N, Test time: 10±1sec.	No remarkable damage or removal of the terminations.
Insulation Resistance Clause 4.6	Apply the maximum overload voltage (DC) for 1minute	R ≥ 1G Ω
Dielectric Withstand Voltage Clause 4.7	Apply the maximum overload voltage (AC) for 1 minute	No breakdown or flashover

PACKAGING

Paper Tape specifications (unit :mm)

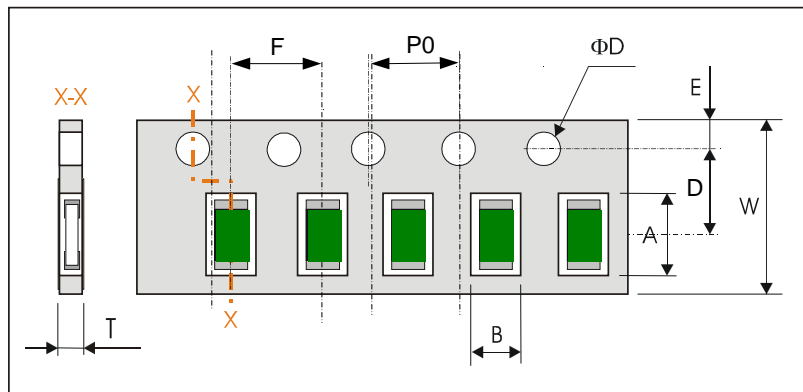

Series No.	A	B	W	D	E
WK12	3.60±0.20	2.00±0.15	8.00±0.30	3.50±0.05	1.75±0.10
WK08	2.50±0.20	1.65±0.15	8.00±0.30	3.50±0.05	1.75±0.10
WK06	1.90±0.20	1.15±0.15	8.00±0.30	3.50±0.05	1.75±0.10
WK04	1.15+0.05/-0.1	0.65±0.10	8.00±0.20	3.50±0.05	1.75±0.10
WK02	0.37±0.05	0.67±0.05	8.00±0.20	3.50±0.05	1.75±0.10

Series No.	F	P0	ΦD	T
WK12	4.00±0.10	4.00±0.10	Φ1.50 ^{+0.1} _{-0.0}	Max. 1.0
WK08	4.00±0.10	4.00±0.10	Φ1.50 ^{+0.1} _{-0.0}	Max. 1.0
WK06	4.00±0.10	4.00±0.10	Φ1.50 ^{+0.1} _{-0.0}	Max. 0.8
WK04	2.00±0.10	4.00±0.10	Φ1.50 ^{+0.1} _{-0.0}	Max. 0.5
WK02	2.00±0.10	4.00±0.10	Φ1.50 ^{+0.1} _{-0.0}	Max. 0.5

Reel dimensions

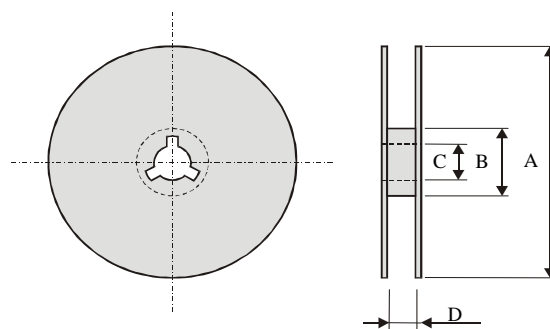

Symbol	A	B	C	D
(unit : mm)	Φ180+0/-1.5	Φ60.0+1/-0	13.0±0.2	9.0+1/-0

Taping quantity

- Chip resistors 5,000 pcs per reel (WK12, WK08, WK06)
- Chip resistors 10,000 pcs per reel (WK04); 15,000pcs per reel (WK02)