

Part Number : **6839**

Type	Size	Rating	Description
Incandescent	T3	28V 24mA	T-1 Sub-Midget Flange lamp

Dimensions(mm):

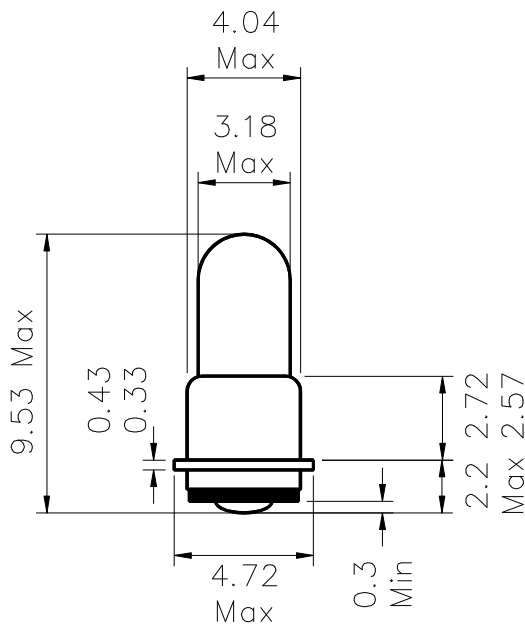

TEST VOLTS	CURRENT (mA)			LIGHT OUTPUT (Lm)			LIFE Hours
	Min.	Nom.	Max.	Min.	Nom.	Max.	
28	21.6	24	26.4	1.4	1.9	2.4	4000

Notes:

- 1 SX4s/4 base to ANSI C81.50b sheet 1-2-1.
- 2 CC-2F filament shape.
- 3 Bead colour: White or Clear
- 4 Lamp Marking: CML6839 or unmarked.
- 5 RoHS and REACH SVHC compliant