

Dual counterbalance with brake release port

VBSO-DE-VF-30-VSDI-FM

06.03.01 - X

RE 18308-55

Edition: 03.2016

Replaces: 04.2010



Description

It provides static and dynamic motion control by regulating the flow IN and OUT of the hydraulic motor, through ports C1 and C2. It includes 2 sections, each one composed by a check and a relief valve pilot assisted by pressure in the opposite line: the check allows free flow into the motor, then locks and prevents reverse movement. With pilot pressure applied at the line across, the pressure setting of the relief is reduced in proportion to the stated ratio until opening and allowing controlled reverse motion. With motor turning and without pilot pressure, the relief function builds up back-pressure at the motor port in order to stop the motion. Back-pressure at V1 or V2 is additive to the pressure setting in all functions. Through port C3, a shuttle valve directs either V1 or V2 line pressure to the spring actuated brake for brake releasing.

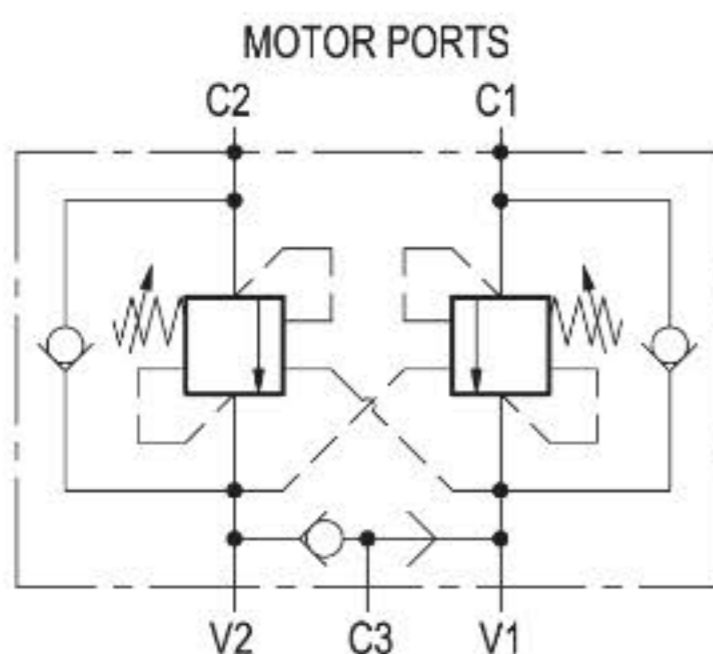

Technical data

Operating pressure	up to 210 bar (3000 psi)
Max. flow	60 l/min. (16 gpm)
Flangeable on SAUER-DANFOSS orbital motors OMP-OMR series.	
Relief setting: at least 1.3 times the highest expected load. In addition, both the relief setting and the pilot ratio must be determined in order to achieve building-up of pilot pressure in V1 or V2 high enough to release the brake prior to any valve opening.	
Weight	1.6 kg (3.5 lbs)
Manifold material	Aluminium
Note: aluminium bodies are often strong enough for operating pressures exceeding 210 bar (3000 psi), depending from the fatigue life expected in the specific application. If in doubt, consult our Service Network.	
Fluid	Mineral oil (HL, HLP) according DIN 51524
Fluid temperature range	-30 °C to 100 (-22 to 212 °F)
Viscosity range	10 to 500 mm ² /s (cSt)
Recommended degree of fluid contamination	Class 19/17/14 according to ISO 4406
Other technical data	see data sheet 18350-50

Note: for applications outside these parameters, please consult us.

Characteristic curve

