

Lochabmessung  
für Montage

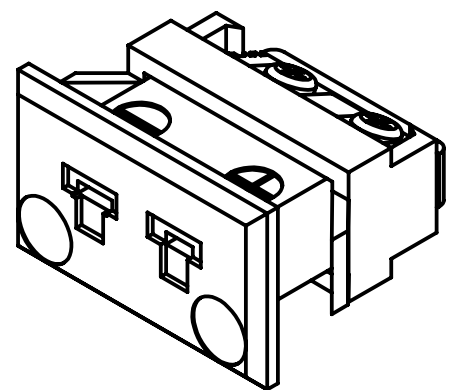

Benennung

**Miniatur Kupplung**

Bemerkung

**für Schalttafelbau**

Artikel-Nr.

**IM-X-FF**

		Name	Datum
Massstab 2:1	Gezeichnet	Ch. Di Ronza	21.12.11
	letzte Änd.	-	-
	Werkstoff	-	-
	Dimension	-	-
Änd. Index 00	<b>ROTH+CO. AG</b> <small>info@rothcoag.ch www.rothcoag.ch</small> Wiesentalstrasse 20 Tel. 071 955 02 02 CH-9242 Oberuzwil Fax. 071 955 02 00		

