



Part no.: 50118542
BT 200M.5
Mounting bracket

Figure can vary

Contents

- Technical data
- Dimensioned drawings
- Accessories

Part no.: 50118542 – BT 200M.5 – Mounting bracket

Technical data

Basic data

Suitable for	18 series sensors 25B series sensors 25C series sensors 28 series sensors 3B series sensors 3C series sensors 5 series sensors 55 series sensors BCL 95 series bar code readers
--------------	---

Mechanical data

Standard designation, stainless steel mounting device	V2A
Design of mounting device	Angle, L-shape
Type of fastening, at system	Through-hole mounting
Type of fastening, at device	Screw type Suited for M3 screws
Type of mounting device	Adjustable
Mounting device material	Stainless steel
ITEM-compatible	No

Classification

Customs tariff number	73182900
eCl@ss 8.0	27279202
eCl@ss 9.0	27273701
ETIM 5.0	EC003015
ETIM 6.0	EC003015

Dimensioned drawings

All dimensions in millimeters

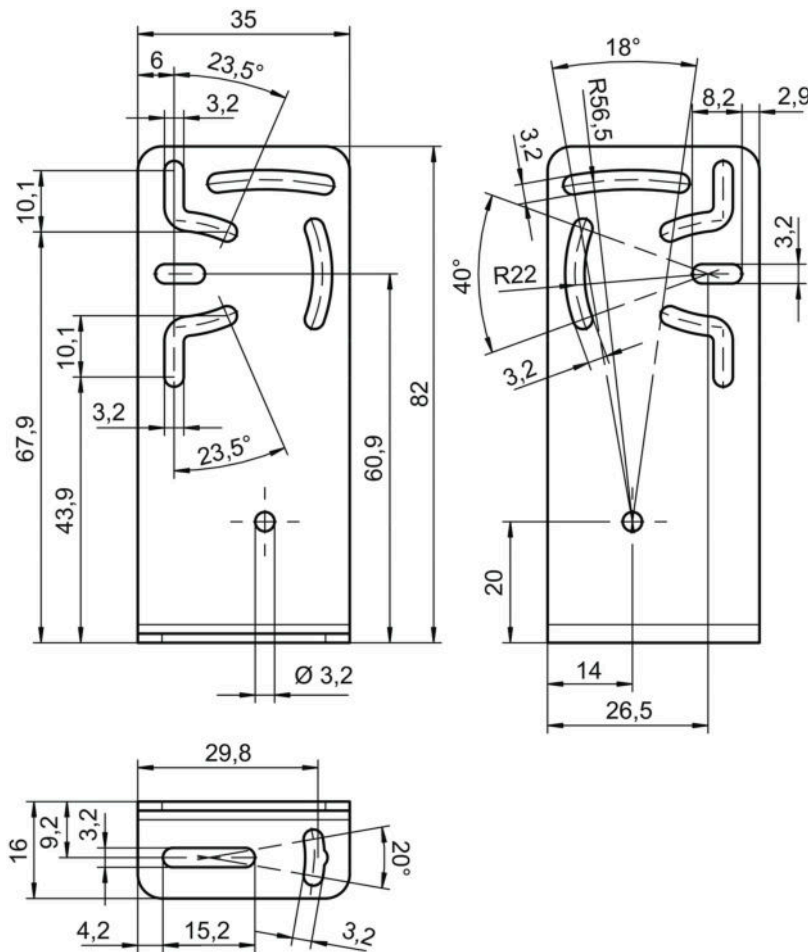

Accessories

Micro-triad-type reflectors

	Part no.	Designation	Article	Description
	50040895	MTKS 20x20	Reflector	Design: Rectangular Reflective surface: 20 mm x 20 mm Triple reflector size: 1.2 mm Material: Plastic Base material: Plastic Chemical designation of the material: PMMA8N Fastening: Through-hole mounting, Adhesive

Note

A list with all available accessories can be found on the Leuze electronic website in the Download tab of the article detailed page.