

SD20-H15-5.5

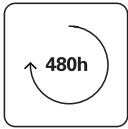
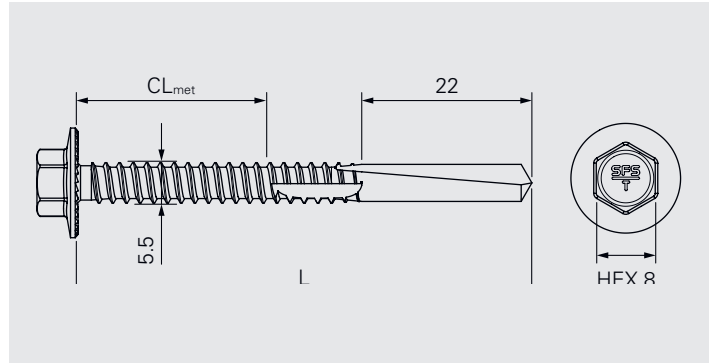

Application

Fastening of metal decks, liner trays onto metal beams

Component 1 (t_I)

Steel	0.50–2.0
Steel	2×0.50–1.50
Aluminium	0.50–2.0

Component 2 (t_{II})

Steel	4.0–18.0
-------	----------

$\Sigma_{\max} t_I + t_{II}$

20.0
21.0
20.0

Fastener material

Carbon steel, Durocoat® 480

Approvals



Features and Benefits

- Self drilling fastener suitable for installation of metal decks and liner trays
- High shear resistance achieved by optimized fastener geometry
- High corrosion durability thanks to special galvanic zinc coating

Documentation

Approval document (ETA) | Declaration of performance (DoP)

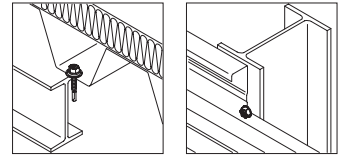

Fastener in carbon steel onto steel

Product code	PU	L	CL _{met}	t _{fix, met}	
SD20-H15-5,5x50	500	50	0-24	0-6/20	1673850

t_{fix, met}: CL_{met, min.} - (CL_{met, max.} - t_{l, max.} or load-bearing clamping length according ETA) / (CL_{met, max.} - t_{l, min.})

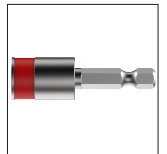

Accessories/Ancillaries

Product code	PU	Drive	Head drive	
E308-¼"-50	1	¼"	HEX8	1646160