

O5 MOUNTING BRACKET 200

Accessories

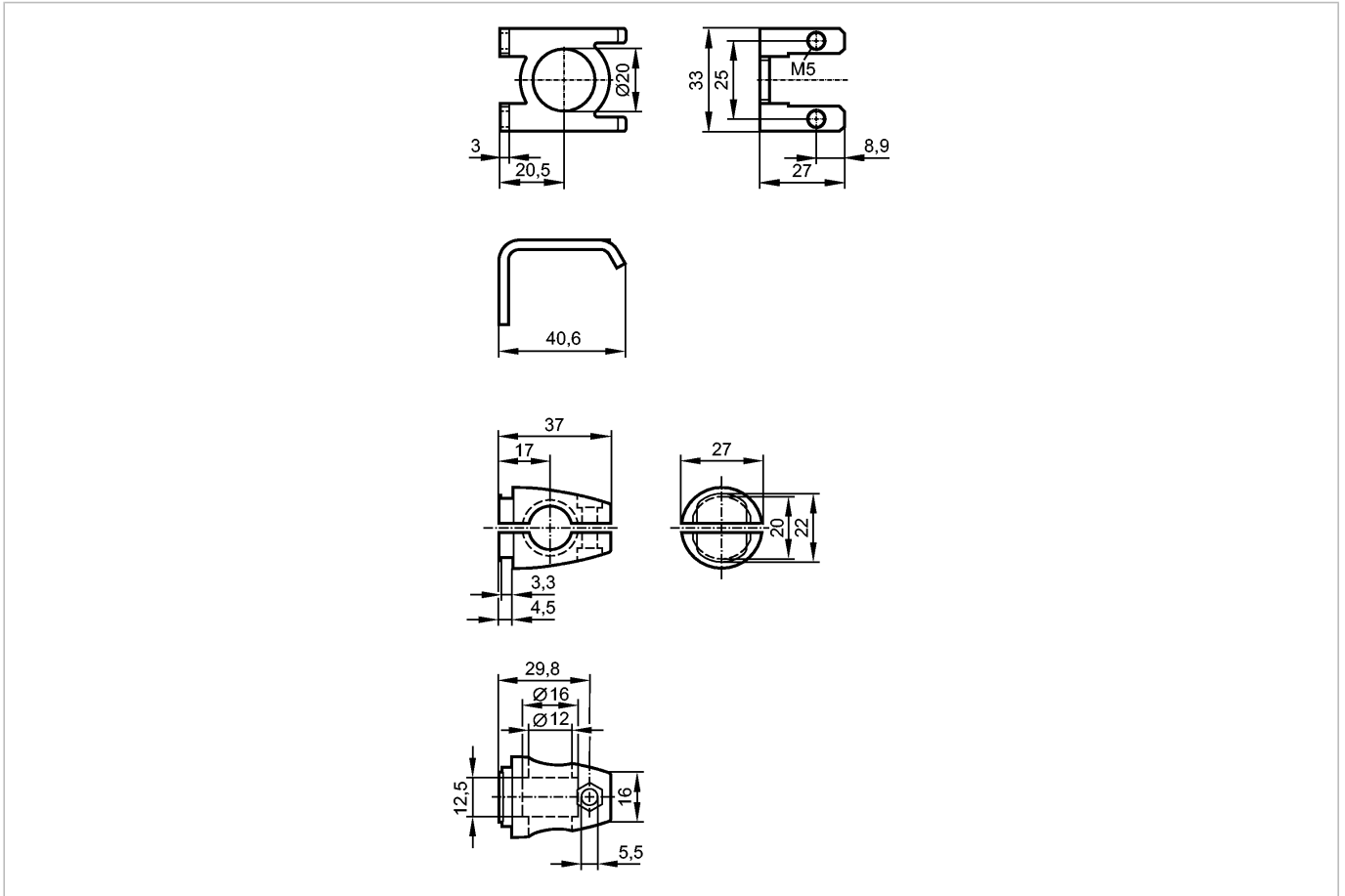

Product characteristics

Mounting set

Clamp mounting

Mechanical data

Design

for types O5

Housing materials

stainless steel 316Ti / 1.4571; clamp: diecast zinc

Type of mounting

rod mounting Ø 14 mm

Weight

[kg]

0.099

Accessories

Accessories (included)

2 cylinder head screw; M5 x 8

Remarks

Pack quantity

[piece]

1