



5 Port Pilot Solenoid Valve Metal Seal Series VFS

Models and Variations

Series	Port Size Effective area (mm ²) (Nl/min)	Configuration	Voltage	Electrical entry	Option (Indicator light and surge suppressor)	Manual override
Body ported	VFS1000 1/8: 9.0 (491)	2 position single 	Standard 100V AC50/60Hz 200V AC50/60Hz 24V DC	DIN connector (D)(Y) 	With indicator light and surge voltage suppressor •Din connector (DZ)(YZ)	Non-locking push style (Flush)
		2 position double 				Non-locking push style (Extended)
	VFS2000 1/8: 16.2 (883) 1/4: 18 (981)	3 position closed centre 3 position exhaust centre 	Option 110 to 120V AC50/60Hz 220V AC50/60Hz 240V AC50/60Hz 12V DC 100V DC	Locking style (Slotted)		
VFS3000 1/4: 32.4 (1777) 3/8: 36.0 (1963)	3 position pressure centre 		Locking style* (Lever)			
*Locking style (Lever) is not available for direct mount series VFS2000, 3000.						
Base mounted	VFS2000 Plug-in Non plug-in 1/8: 12.6 (687) 1/4: 15 (815)	2 position single 	Standard 100V AC50/60Hz 200V AC50/60Hz 24V DC	Plug-in Conduit terminal (F) 	<input type="checkbox"/> With indicator light and surge voltage suppressor •Non plug-in Din connector (DZ)(YZ)	Non-locking push style (Flush)
		2 position double 				Non-locking push style (Extended)
	VFS3000 Plug-in Non plug-in 1/4: 32.4 (1777) 3/8: 36.0 (1963)	3 position closed centre 	Option 110 to 120V AC50/60Hz 220V AC50/60Hz 240V AC50/60Hz 12V DC 100V DC	Plug-in Conduit terminal (F) 	<input type="checkbox"/> With indicator light and surge voltage suppressor •Plug-in Conduit terminal (FZ) •Non plug-in Din connector (DZ)(YZ)	Locking style (Slotted)
		3 position exhaust centre 				Locking style (Lever)
	VFS4000 Plug-in Non plug-in 3/8: 59.4 (3239) 1/2: 64.8 (3533)	3 position pressure centre 	Non plug-in DIN connector (D)(Y) 	<input type="checkbox"/> With indicator light and surge voltage suppressor •Plug-in Conduit terminal (FZ) •Non plug-in Din connector (DZ)(YZ)		
		3 position double check 				
VFS5000 Plug-in Non plug-in 3/8: 78.7 (4319) 1/2: 97.2 (5300) 3/4: 102.6 (5595)						
VFS6000 Plug-in Non plug-in 3/4: 162 (8833) 1: 180 (9815)						

Series VFS

Manifold Variations

		Manifold Type						
		Bar base	Stacking base	Insert plug with lead wire	With terminal block	With multi-connector	With D-sub connector	Non plug-in
Body Ported	VFS1000	●						
	VFS2000	●						
	VFS3000		●					
Base Mounted Plug-in	VFS2000			●	●	●	●	
	VFS3000				●	●	●	
	VFS4000				●	●	●	
	VFS5000				●	●	●	
Base Mounted Non Plug-in	VFS2000							●
	VFS3000							●
	VFS4000							●
	VFS5000							●

Bar base (Series VFS1000, 2000)

Individual pilot exhaust

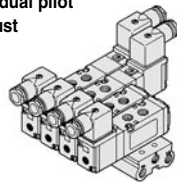

Common pilot exhaust

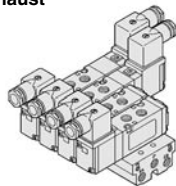

Plug-in

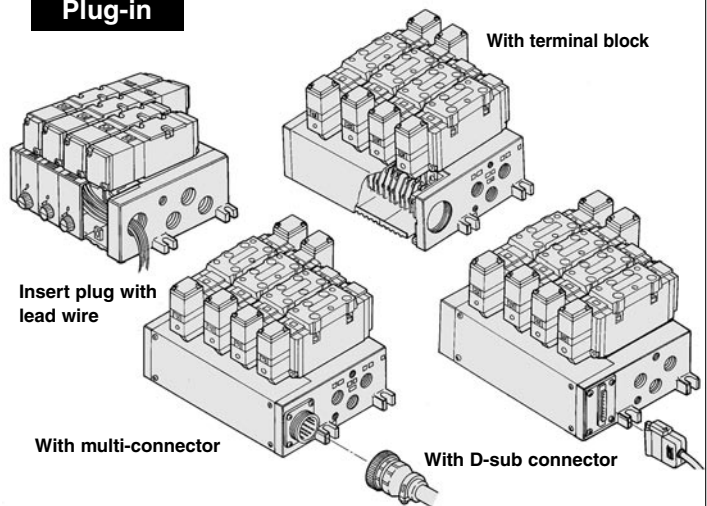

Non plug-in

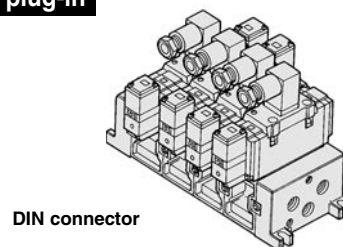

*Bottom porting is optional.



Manifold Options

With exhaust cleaner With control unit Serial interface unit

Manifold Optional Parts

Individual SUP spacer Individual EXH spacer SUP block disk EXH block disk Interface speed control Interface regulator Air shutoff valve spacer Air release valve spacer Double check spacer Blank plate

	With exhaust cleaner	With control unit	Serial interface unit	Individual SUP spacer	Individual EXH spacer	SUP block disk	EXH block disk	Interface speed control	Interface regulator	Air shutoff valve spacer	Air release valve spacer	Double check spacer	Blank plate
													●
													●
													●
		●	● (1)	●	●	●	●	●	●	●	●	●	●
	●	●	● (1)	●	●	●	●	●	●		●	●	●
	●	●	● (1)	●	●	●	●	●	●		●	●	●
	●		● (1)	●	●	●	●	●	●			●	●
		●		●	●	●	●	●	●	●	●	●	●
	●	●		●	●	●	●	●	●		●	●	●
	●	●		●	●	●	●	●	●		●	●	●
	●	●		●	●	●	●	●	●		●	●	●
	●			●	●	●	●	●	●			●	●

With exhaust cleaner

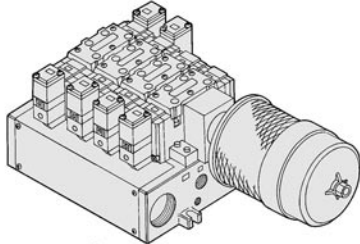

With control unit

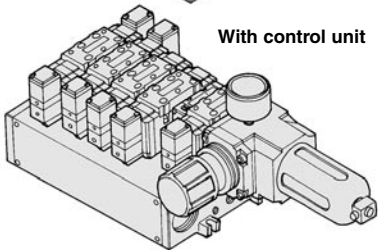

Serial interface unit

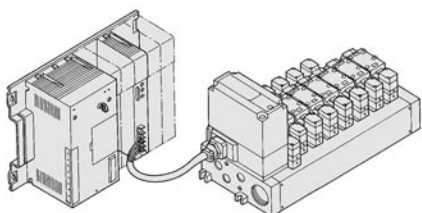

Individual SUP spacer

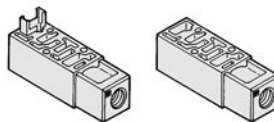

Individual EXH spacer

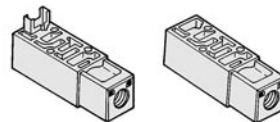

SUP/EXH block disk



Interface speed control

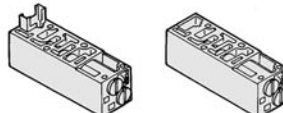

Interface regulator

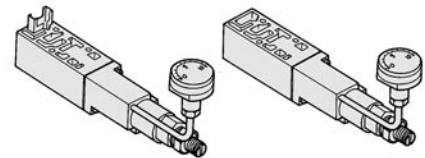

Air shutoff valve spacer

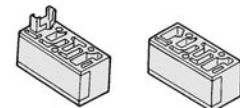

Air release valve spacer

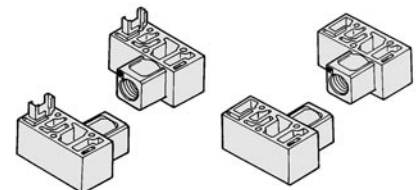

Double check spacer

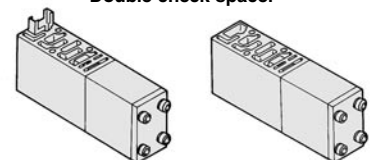

Note 1) Available.

⚠ Precautions

Be sure to read before handling. Refer to p.0-33 to 0-36 for Safety Instructions and common precautions.

⚠ Caution

Light/Surge Voltage Suppressor/Electrical Entry Single Unit

Body Ported

Series VFS1000, 2000, 3000

Light/Surge Voltage Suppressor

AC and 100V DC

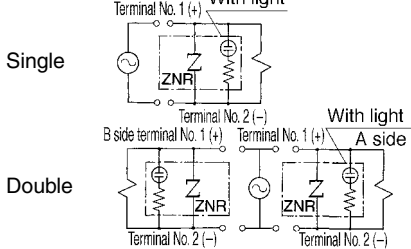

24V DC or less

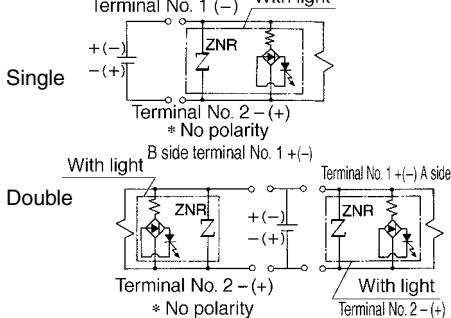

Wiring

In the case of DIN connector and Terminal block (with indicator light/surge voltage suppressor), the interior wiring is shown below.

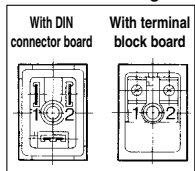

Applicable terminal: 1.25-3, 1.25-3S, 1.25Y-3N, 1.25Y-3S. But, in the case of DIN connector board, it is not a terminal structure.

* No polarity

To Change Direction of DIN Connector

To change direction of DIN connector retaining screw, pull off outer cover, rotate connector board through 180°. Replace cover and tighten screw.

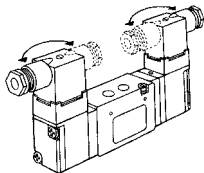

Changing Direction of Electrical Entry and Manual Override (Series VFS1000 only)

Loosen the set screw (M3-2pcs.), take out pilot operator, turn solenoid valve 180° degrees to change the direction of lead wire and manual override. (Possible on Series VFS1000 only.)



Base Mounted

Series VFS2000

Light/Surge Voltage Suppressor

In the case with surge voltage suppressor, surge voltage absorption device ZNR is attached to AC power.

AC and 100V DC

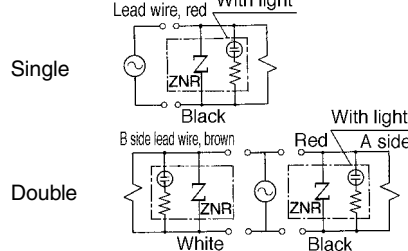

24V DC or less

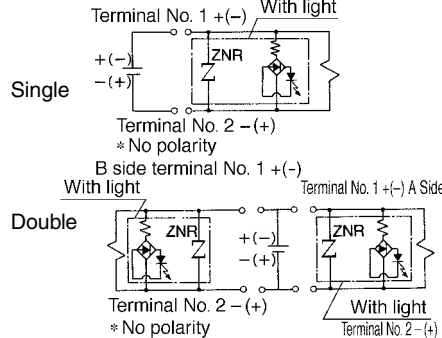

With indicator light and surge voltage suppressor

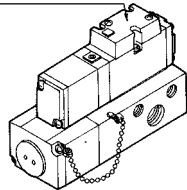

Plug-in

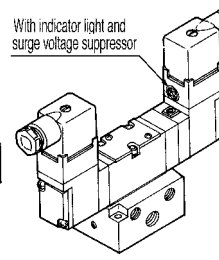

Non Plug-in

How to Exchange

Solenoid valve

- Loosen 3 set screws (hexagonal socket head cap screw M3 X 31) and pull solenoid valve out vertically, otherwise it may cause damage to the solenoid valve. Never remove a valve at an angle.
- When mounting solenoid valve onto the base, plug pin ass'y (base-side) into receptacle ass'y (body-side) vertically.

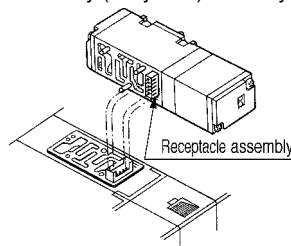

Pilot valve

- When changing rated voltage and electrical entry etc., pilot valve assembly can be exchanged since this is a plug-in style.

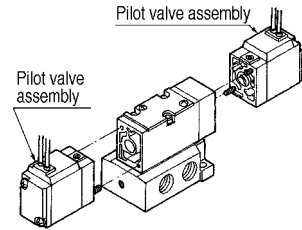

Wiring

Valve/Sub-plate porting plug-in : T Conduit with terminal (with terminal block)

- Remove junction cover ① of subplate, and you can see plug-in terminal block board ② (Part No. NVF2000-27A-1) attached to the inside of the subplate.

- The following markings are on the terminal block

Designation	Solenoid A-side	Solenoid B-side
Terminal block board marking	A	B

- No polarity
- When ground wiring and COM wiring are required, please specify separately.
- Applicable terminal: 1.25-3, 1.25-3S, 1.25Y-3N, 1.25Y-3S

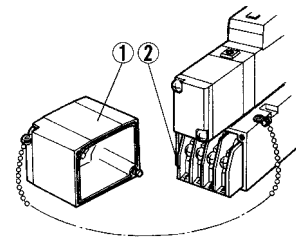

Valve/Sub-plate porting non plug-in: D

- G type:** Use lead wire from solenoid to connect with power side.
- E, T, D-type:** In the case of a DIN connector and terminal block (with light/surge voltage suppressor), the interior wiring is shown below. Please connect with corresponding power side.

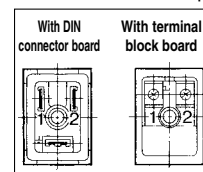

Applicable terminal: 1.25-3, 1.25-3S, 1.25Y-3N, 1.25Y-3S. But in the case of with DIN connector board, is not a terminal structure.

* No polarity

Changing Direction of DIN Connector/Cable Entry

- Unscrew retaining screw, pull off outer cover, rotate connector board through 180°. Replace cover and tighten screw.
- Applicable cable: O. D. $\phi 6$ to $\phi 8$.

⚠ Caution

Light/Surge Voltage Suppressor/Electrical Entry

Single Unit

Base Mounted

Series VFS3000, 4000, 5000, 6000

Light/Surge Voltage Suppressor

In the case of voltage suppressor, surge voltage absorption element is attached to terminal block on body area.

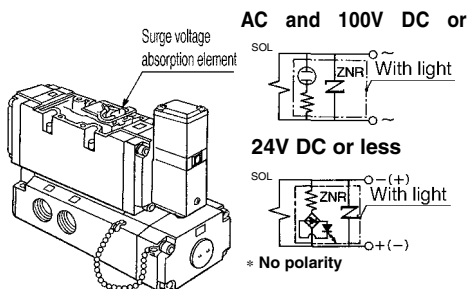

How to Exchange

Solenoid valve

- Loosen set screw and take solenoid valve out vertically, otherwise it may cause damage to the solenoid valve. Never remove a valve at an angle.
- When mounting solenoid valve onto the base, plug pin ass'y (base-side) into receptacle ass'y (body-side) vertically.

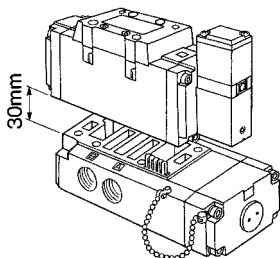

Pilot valve

- When changing the rated voltage, electrical entry, etc., pilot valve ass'y can be exchanged easily since this is plug-in style. Then, when changing the rated voltage with light/surge voltage suppressor, change of light/surge voltage suppressor substrate is also needed. So, order together with pilot valve assembly.

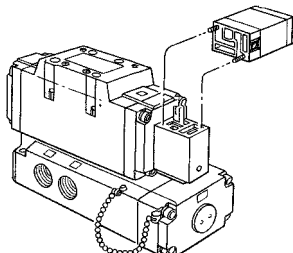

Light and surge voltage suppressor substrate part No.

VFS3000	VFS3000-10A-□
VFS4000	VF4000-9A-□
VFS5000	AXT627-7A-□
VFS6000	VF4000-9A-□

-□: Voltage

Wiring

DIN connector

- Male pin terminal of DIN connector block board of solenoid valve and wires as shown below. Please connect each valve to corresponding terminal block on connector.

DIN connector (Wiring)

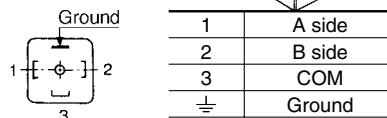

No polarity applies.

AC and 100V DC or more.

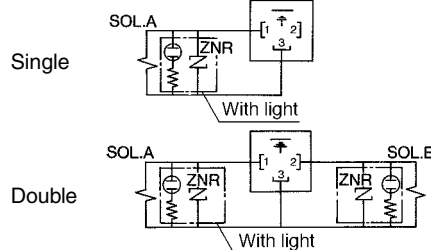

24V DC or less

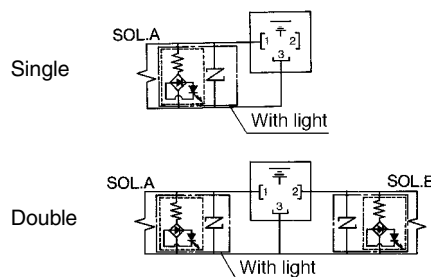

- Cable
 - Applicable cable O. D.: $\phi 6.8$ to $\phi 11.5$
- Applicable terminal
 - Applicable terminal on block board: 3 (kinds)
 - 1.25Y-3L, 1.25-3.5S, 1.25-4M
- Connector/Clamping torque
 - Set screw 6kgf-cm
 - Terminal screw 9kgf-cm
- Incorrect common (DIN connector No.3) causes damage on power side circuit.

Plug-in (with terminal)

- If removing the junction cover ① on the sub-plate, there appears the plug-in style terminal block ② attached to the inside of sub-plate.

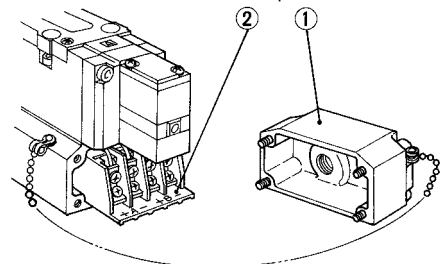

- The following marking are on the terminal block. Connect with corresponding power side.

Terminal block Marking	Solenoid A side		Solenoid B side	
	A	B	B	A
	+	-	+	-

Applicable terminal

- VFS3000: 1.25-3, 1.25-3S, 1.25Y-3N, 1.25Y-3S
- VFS4000: 1.25-3.5M, 1.25Y-3L, 1.25Y-3M
- VFS5000: 1.25-4, 1.25-4M
- VFS6000: 1.25-3.5M, 1.25Y-3L, 1.25-3M

- No polarity applies.

Series VFS

⚠ Caution

Maintenance

① A lot of carbon powder and oil waste from air sources (mostly from compressor) entering into the valve sometimes can lead to increased sliding resistance at the switching spool and cause valve malfunction. In the worst case, spool can adhere to the valve. Therefore supply air should be kept clean.

Also please note that if pressurized states on SUP is left for a long time with inferior air quality, carbon powder and oil waste in the compressed air accumulate in the clearance of spool and the sleeve, and can cause the spool to adhere to the valve. The remedy for this case is to check the compressor lubrication oil and find out the least oxidizing compressor lubrication oil.

Meanwhile, a high filtration Mist Separator (Series AM) installed on the back of regular filter (Series AF) can prevent foreign particles from entering into the valve.

② In case foreign matter from the air source adheres to spool and sleeve, disassemble the adapter plate section and end plate section (return spring insert section).

Then, take out spool and sleeve from valve and clean them with trichlene or freon solutions, when cleaning, prevent O rings from touching cleaning solutions.

③ When disassembling and re-assembling, please ensure that all components are in proper positions. Prevent gaskets from slipping, and clamp bolts down equally. Use torques listed below when mounting pilot valves and solenoid valve bodies.

Pilot valve assembly

Set screw	Correct clamping torque (Nm)
M3	4.5 to 6

Solenoid valve body

Set screw	Correct clamping torque (Nm)
M3	8 to 12
M4	14 to 25
M5	28 to 50

How to Calculate Flow Rate

See p.0-36 for calculating flow rate.

Interface Regulator Specifications

Model ⁽¹⁾	ARBF2000	ARBF3050	ARBF4050	ARBF5050
Applicable solenoid valve series	VFS2000	VFS3000	VFS4000	VFS5000
Regulation	P	A B P	A B P	A B P
Proof pressure	1.5MPa			
Max. operating pressure	1.0MPa			
Set pressure range	0.1 to 0.83MPa ⁽²⁾			
Ambient and fluid temperature	5 to 60°C			
Gauge connecting port	M5	1/8		
Weight (kg)	0.16	0.46	0.72	0.83
Effective area of the supply side (mm ²) ⁽³⁾	P→A	5.5	21 18.5 11	35 31 26 44 38 32
S at P ₁ =0.7MPa, P ₂ =0.5MPa	P→B	5.1	18.5 22 12	31 31 24 38 40 31
Effective area of the exhaust side (mm ²) ⁽³⁾	A→EA	12	40	55 90
S at P ₂ =0.5MPa	B→EB	11	36	45 77

Note 1) Set within the operating pressure range of solenoid valve.

Note 2) Synthesized effective area with solenoid valve 2 position single style.

Note 3) •To supply air to Interface Regulator P port is the only supply port except for when used with a reverse pressure valve.

•To combine a pressure center valve and the A and B port pressure reduction of a spacer style regulator, use the ARBF3000, 4000, or 5000 model.

•To combine a reverse pressure valve and a spacer style regulator, use the ARBF3000, 4000, or 5000 model. The P port pressure reduction cannot be used.

•To combine a double check valve and interface regulator, use the manifold or the sub-plate as a reference, and stack them in the order of the double check spacer, the interface regulator and the valve.

•A closed centre valve cannot be used combined with an interface regulator for applications of cylinder intermediate stops as there is leakage from the relief port of the interface regulator.

Flow Characteristics (P→A)

(Conditions: Supply pressure 0.7MPa.
When 2 position solenoid valve is mounted.)

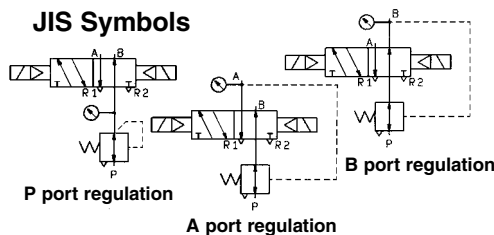

ARBF2000-00-P

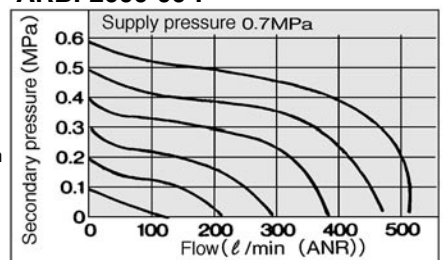

ARBF3050-00-P

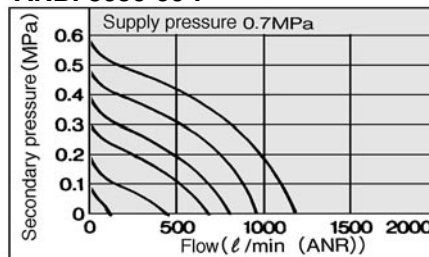

ARBF3050-00-A

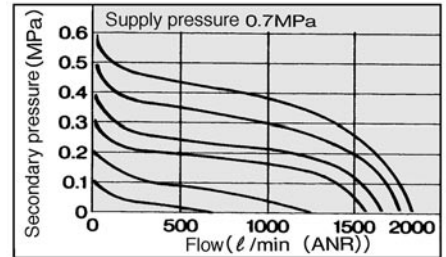

ARBF4050-00-P

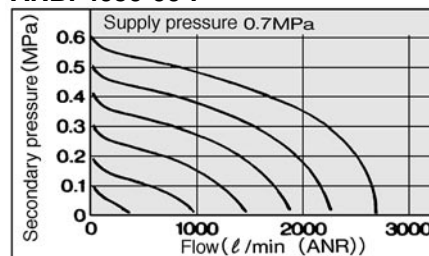

ARBF4050-00-A

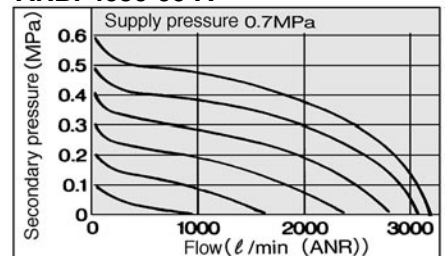

ARBF5050-00-P

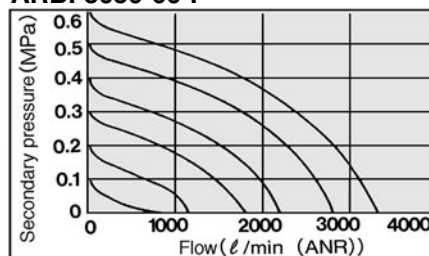

ARBF5050-00-A

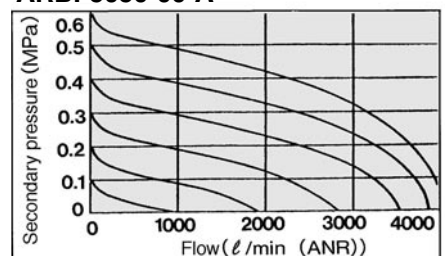

⚠ Caution

Wiring Manifold/Plug-in

01 Type Insert Plug with Lead Wire

Series VFS2000 (Only VFS2000) (Insert plug with lead wire is not available for VF3000, 4000, and 5000.)

How To Remove Junction Cover (01 Type)

- Turn the knob ② of junction cover ① on the manifold block side by hand or slotted screwdriver to the C/O direction (counter-clockwise) 90°. While holding the knob and upper part of junction cover, pull outward to remove junction cover.

When reassembling, do the opposite.

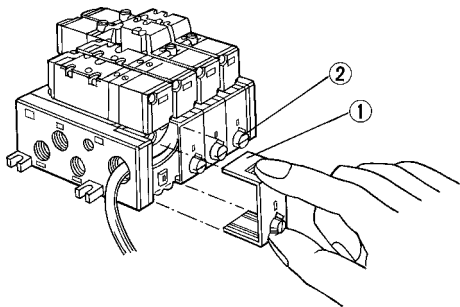

How To Use Insert Plug

- When removing insert plug ① from manifold base, push the lever area ② of insert plug downward with thumb and pull it together with the lead wire ③ outward.

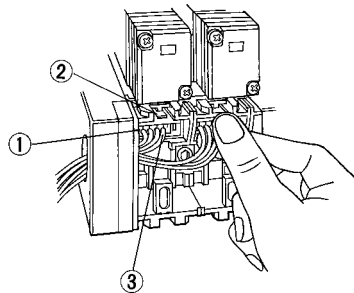

- When placing the insert plug ① into the manifold base, push the lever area of insert plug with thumb and plug it in its place in the receptacle housing ④ horizontally. After plugging, pull lead wire out a little bit to ensure that insert plug is secure.

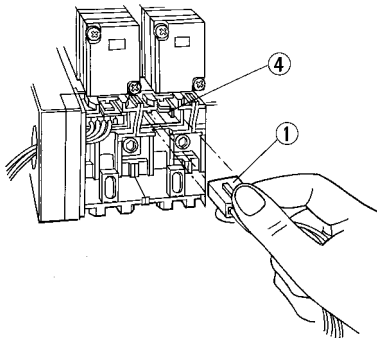

Wiring

The insert plug ① is attached to the manifold block and lead wire is plugged in with valve side as shown in the following list.

(Single solenoid: AXT624-52A-S-1)
(Double solenoid: AXT624-52A-D-1)

Please connect with corresponding power side.

Power	Valve	Solenoid A	Solenoid B
AC	Single solenoid	Red, Black	—
DC	Double solenoid	Red, Black	Brown, White

* No polarity applies.

* Lead wire length is 1m.

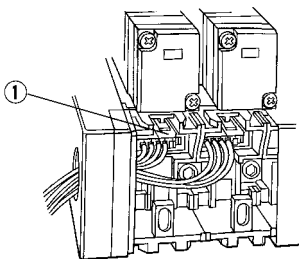

01T Type with Terminal Block

Series VFS2000

- Remove junction cover of manifold, exposing terminal block attached to the manifold block. Lead wires from solenoid valve are connected with the terminals on upper side of terminal block. (On the terminal block, lead wire is connected with both A and B sides of solenoid valve in accordance with the corresponding markings A and B on the block.)

Connect each lead wire of power side corresponding to respective solenoid valve on the lower terminal block.

Model	Marking	A	COM	B
VFS2100		A side	COM	
VFS2200		A side	COM	B side
VFS2 $\frac{3}{4}$ 00		A side	COM	B side

- Applicable terminal: 1.25-3, 1.25-3S, 1.25Y-3N, 1.25Y-3S

- Plugging COM bridge (Part No. AXT625-73: 5 stations) in between each + COM on the block board will make the specifications of all the stations + COM and enables you to understand the wiring process.

- No polarity.

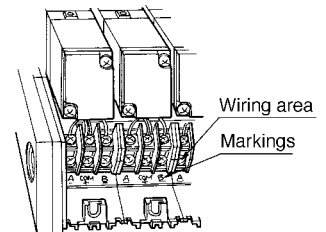

Series VFS3000

Model	Marking	A	COM	B
VFS3100		A side	COM	
VFS3200		A side	COM	B side
VFS3 $\frac{3}{4}$ 00		A side	COM	B side

- Applicable terminal: 1.25-3.5M, 1.25Y-3L, 1.25-3M

- No polarity.

- VFS 3000 has the marking + COM on the block board, but - COM specification is also available.

Series VFS4000, 5000

Model	Marking	A+	A-	B+	B-
VFS $\frac{4}{5}$ 100		A side	A side		
VFS $\frac{4}{5}$ 200		A side	A side	B side	B side
VFS4 $\frac{3}{4}$ 00		A side	A side	B side	B side
VFS5 $\frac{3}{4}$ 00		A side	A side	B side	B side

- Applicable terminal: 1.25-3.5M, 1.25Y-3L, 1.25Y-3M

- No polarity

Series VFS

⚠ Caution

Lead Wire Wiring

Manifold/Plug-in

01C Type with Multi-connector

Series VFS2000, 3000, 4000, 5000

•Wiring

Manifold interior wiring is in accordance with + COM specifications and is connected with both the A side and B side of the solenoid valve by a receptacle terminal as shown below.

Diagram 1

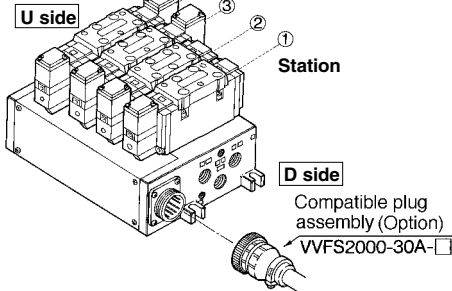

Manifold Interior Wiring

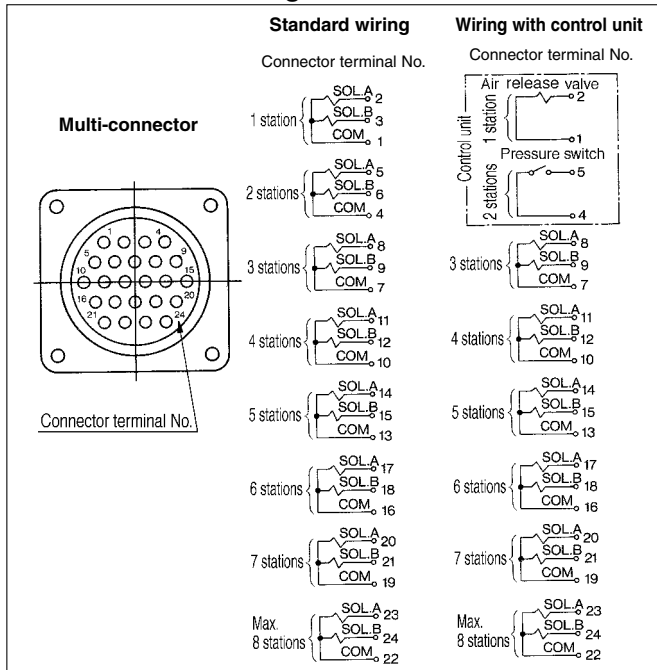

Note 1) Maximum stations: 8 Note 2) No polarity
Note 3) Indications of stations are one station from D side regardless of the connector mounting side, D

Applicable Plug Assembly (Option)

Assembly part No.	Cable length	Components
VVFS2000-30A-1	1.5m	AMP Japan Plug: 206837-1 (1 pc.) Cable clamp: 206138-1 (1 pc.) Socket: 66105-2 (24 pcs.) Cable: VCTF24-wire, 0.75mm ²
VVFS2000-30A-2	3m	
VVFS2000-30A-3	5m	
VVFS2000-30A-4 *	7m	
VVFS2000-30A-5 *	10m	
VVFS2000-30A-6 *	15m	
VVFS2000-30A-7 *	20m	

*Option

Wire Color Table

Terminal No.	1	2	3	4	5	6	7	8	9	10	11	12	13	14	15	16	17	18	19	20	21	22	23	24
Lead wire colour	1	2	3	4	5	6	7	8	9	10	11	12	13	14	15	16	17	18	19	20	21	22	23	24
Dot marking	—	5	—	2	—	7	—	4	—	1	—	6	—	9	—	3	—	10	—	8	—	12	—	6

1)Orange, 2)Black, 3)Green, 4)Red, 5)Blue, 6)Yellow, 7)Brown, 8)White, 9)Pink, 10)Grey, 11)Sky blue, 12)Bright green, 13)Purple

01F Type with D-sub Connector

Series VFS2000, 3000, 4000, 5000

•Wiring

Manifold interior wiring is in accordance with + COM specifications and is connected with both the A side and B side of the solenoid valve by the receptacle terminal as shown below.

Diagram 2

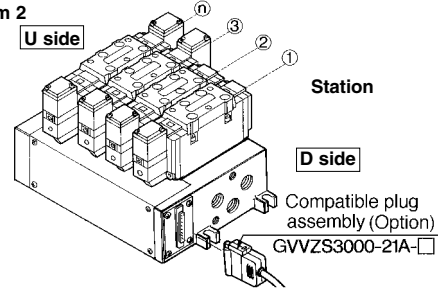

Manifold Interior Wiring

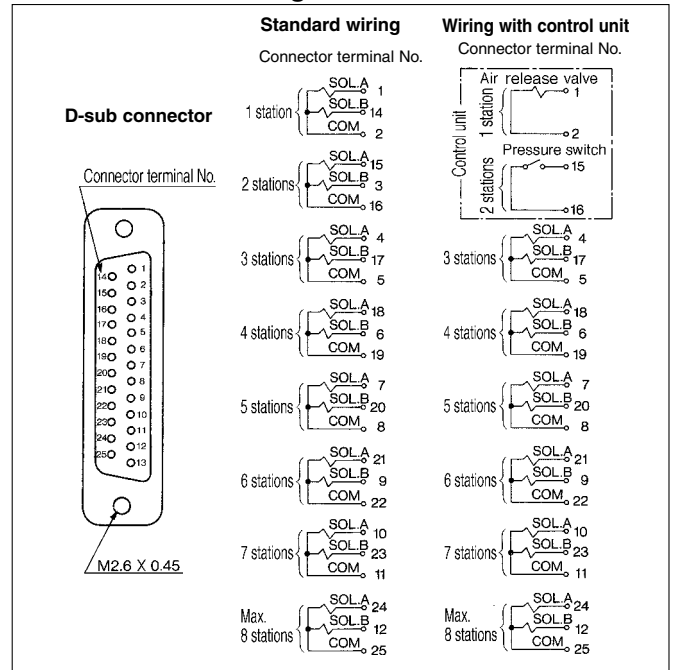

Note 1) Maximum stations: 8 Note 2) No polarity
Note 3) Indications of stations are one station from D side regardless of the connector mounting side, D

Applicable Plug Assembly (Option)

Assembly part No.	Cable length	Components
GVVZS3000-21A-1S	1m	Plug: MIL standard D type connector 25 terminals Cable: 25-wire, 0.3mm ²
GVVZS3000-21A-2S	3m	
GVVZS3000-21A-3S	5m	
GVVZS3000-21A-4S	8m	
GVVZS3000-21A-5S	20m	

Wire Color Table

Terminal No.	1	2	3	4	5	6	7	8	9	10	11	12	13	14	15	16	17	18	19	20	21	22	23	24	25
Lead wire colour	8	7	4	6	10	9	5	4	2	8	10	4	8	7	8	6	8	10	8	9	8	7	8	7	8
Dot marking	—	—	—	—	—	—	—	—	—	9	5	3	3	6	7	10	7	9	7	5	5	4	4	8	

1)Orange, 2)Black, 3)Green, 4)Red, 5)Blue, 6)Yellow, 7)Brown, 8)White, 9)Pink, 10)Grey, 11)Sky blue, 12)Bright green, 13)Purple

5 Port Pilot/Metal Seal Body Ported Series VFS1000

**Compact and Large Flow
Capacity: 491N/min
Small Power Consumption/
1.8W DC**



Model

Configuration		Model		Port size	Effective area (mm ²) (Nl/min)	Max. operating cycle (CPM) ⁽¹⁾	Response time (ms) ⁽²⁾	Weight (kgf) ⁽³⁾
2 position	Single	VFS1120	VFS1130	1/8	9.0 (491)	1200	15 or less	0.18
	Double	VFS1220	VFS1230	1/8	9.0 (491)	1200	13 or less	0.26
3 position	Closed centre	VFS1320	VFS1330	1/8	7.2 (393)	600	20 or less	0.27
	Exhaust centre	VFS1420	VFS1430	1/8	9.0 (491)	600	20 or less	0.27
	Pressure centre	VFS1520	VFS1530	1/8	8.8 (481)	600	20 or less	0.27



Note 1) According to JISB8375 (Once per 30 days) for the minimum operating frequency.

Note 2) According to JISB8375-1981. (The valve at supply pressure 0.5MPa.)

Note 3) In case of a grommet.

Note 4) The factors of "Note 1)" and "Note 2)" are achieved in controlled clean air.

Standard Specifications

Valve	Fluid		Air and inert gas	
	Max. operating pressure		1.0MPa	
	Min. operating pressure	2 position	0.1MPa	
		3 position	0.15MPa	
	Proof pressure		1.5MPa	
	Ambient and fluid temperature		-10 to 60°C ⁽¹⁾	
	Lubrication		Not required ⁽²⁾	
	Pilot valve manual override		Non-locking push style (Flush)	
	Shock/vibration resistance		150/50m/s ² ⁽³⁾	
	Protection structure		Dust proof (protection level 0) ⁽⁴⁾	
Solenoid	Rated voltage		100V, 200V AC (50/60Hz), 24V DC	
	Allowance voltage		-15% to +10% rated voltage	
	Coil insulation		Class B or equivalent ⁽⁵⁾	
	Apparent power (Power consumption)	AC	Inrush	5.6VA (50Hz), 5.0VA (60Hz)
			Holding	3.4VA (2.1W)/50Hz, 2.3VA (1.5W)/60Hz
	Power consumption DC		1.8W	
	Electrical entry		DIN connector	



Note 1) Use dry air at low temperatures.

Note 2) Use turbine oil No.1 (ISO VG 32), if lubricated.

Note 3) Shock resistance: No malfunction on test using drop impact tester, to axis and right angle directions of and armature main valve, each one time when energized and deenergized. (Valve in the initial stage.)

Vibration resistance: No malfunction on test with 8.3 to 2000Hz, 1 sweep, to axis and right angle directions of and armature main valve, each one time when energized and de-energized. (Valve in the initial stage.)

Note 4) Based on JIS C0902.

Note 5) Based on JIS C4003.

JIS Symbol

2 position	3 position
Single	Closed centre
Double	Exhaust centre
	Pressure centre

Option Specifications

Manual override	Non-locking push style (Extended), Locking style (Slotted), Locking style (Lever)
Voltage	110 to 120V, 220V, 240V AC (50/60Hz)
	12V, 100V DC
Option	With indicator light and surge voltage suppressor ⁽¹⁾
Foot bracket (with screw)	Part No. AXT626-10A, VFS1120 (single) only



Note 1) No light for grommet but surge voltage suppressor (direct connecting lead wire) is installed.

Manifold

Valve model	Applicable manifold base (Pilot EXH)
VFS1□20	Bar manifold (Individual EXH)
VFS1□30	Bar manifold (Common EXH. base side)



Note) VFS1□30: Manifold only. Cannot be used as a single unit.

VFS1000

How to Order

VFS1 **1** **20** **1** **D** **01** **Q**

Ordering source area code

Code	areas
-	Japan, Asia Australia
E	Europe
N	North America

Configuration

1	2 position single
2	2 position double
3	3 position closed centre
4	3 position exhaust centre
5	3 position pressure centre

Body (Pilot exhaust)

20: Individual EXH

30: Common EXH*

*Manifold only.

Thread

-	Rc (PT)
N	NPT
T	NPTF
F	G (PF)

Port size

01	1/8
----	-----

Optional accessory

F: Foot bracket

*Only for VFS1120.

Manual override

-	Non-locking push style (Flush)	A: Non-locking push style (Extended)*	B: Locking style (Slotted)*	C: Locking style (Lever)*
---	--------------------------------	---------------------------------------	-----------------------------	---------------------------

*Option

Indicator light/surge voltage suppressor

-	None
Z	With indicator light and surge voltage suppressor

Electrical entry

D: DIN connector	Y: DIN connector (DIN 43650)
DO: Without connector	YO: Without DIN connector

Voltage

1	100V AC (50/60Hz)
2	200V AC (50/60Hz)
3	110V to 120V AC (50/60Hz)
4	220V AC (50/60Hz)
5	24V DC
6	12V DC
7	240V AC (50/60Hz)
9	Other (250 or less)

Contact SMC for other voltages (9)

Protective class class I (Mark: ⚡)

How to Order Pilot Valve Assembly

SF4 **1** **DZ** **21** **Q**

Voltage

1	100V AC 50/60Hz
2	200V AC 50/60Hz
3	110 to 120V AC (50/60Hz)
4	220V AC 50/60Hz
5	24V DC
6	12V DC
7	240V AC 50/60Hz
9	Other(250 or less)

Electrical entry/Indicator light and surge voltage suppressor

D	DIN connector
DZ	DIN connector with indicator light and surge suppressor
DO	DIN connector*
DOZ	DIN connector with indicator light and surge suppressor*
Y	DIN Connector (DIN 43650B)
YO	Without connector

*Without DIN connector.

Manual override

-	Non-locking push style (Flush)
A*	Non-locking push style (Extended)
B*	Locking style (Slotted)
C*	Locking style (Lever)

*Option

Applicable model

21	For VFS1□20	Individual pilot exhaust
22	For VFS1□30	Common pilot exhaust

Contact SMC for other voltages (9)

Protective class class I (Mark: ⚡)

Maximum Cylinder Speed

Conditions: Supply pressure 0.5MPa, Load factor 50%

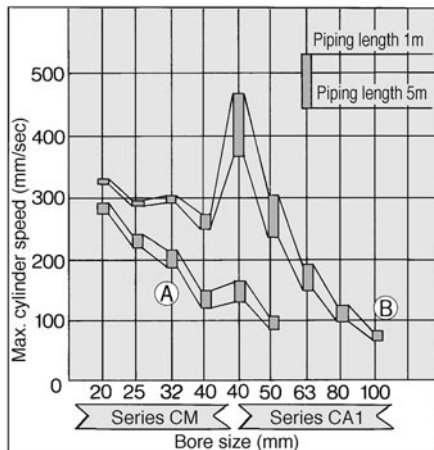

System diagram

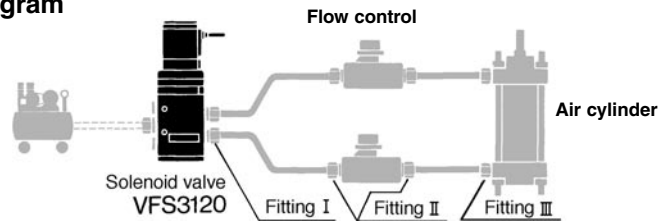

System	Solenoid valve	Port size	Nylon tube O.D./I.D.	Silencer	Speed controller	Fitting (Tube O.D. X Port size)		
						1	2	3
A	VFS1□20-01	1/8	ø4/3	AN110 -01	AS1000-01 or AS2000-01	ø4 X 1/8	ø4 X 1/8	ø4 X 1/8 to 1/4
B	VFS1□20-01	1/8	ø6/4.5		AS4000-02	ø6 X 1/8	ø6 X 1/8	ø6 X 1/8 to 1/2

Construction

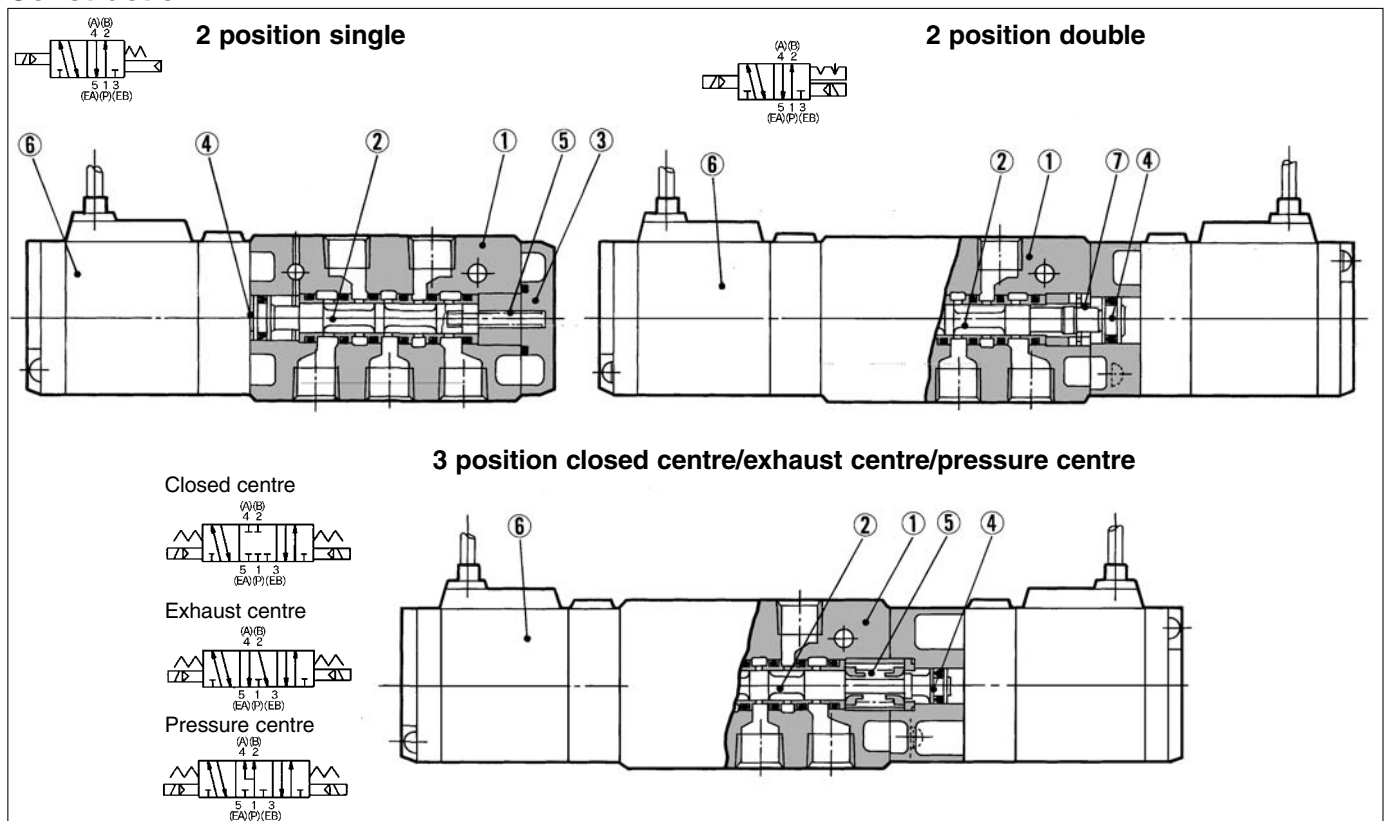

Component Parts

No.	Description	Material	Note
①	Body	Aluminium die-cast	Platinum silver
②	Spool/Sleeve	Stainless steel	—
③	End plate	Resin	—
④	Piston	Resin	—

Replacement Parts

No.	Description	Material	Part No.		
			VFS1120	VFS1220	VFS1320, 1420, 1520
⑤	Return spring	Stainless steel	AXT626-6	—	AXT626-19
⑥	Pilot valve assembly	—	Refer to "How to order Pilot valve assembly" on p.1.17-10.		
⑦	Detent assembly	—	—	AXT624-11A	—

VFS1000

2 Position Single DIN Connector

Grommet: VFS1120-□G

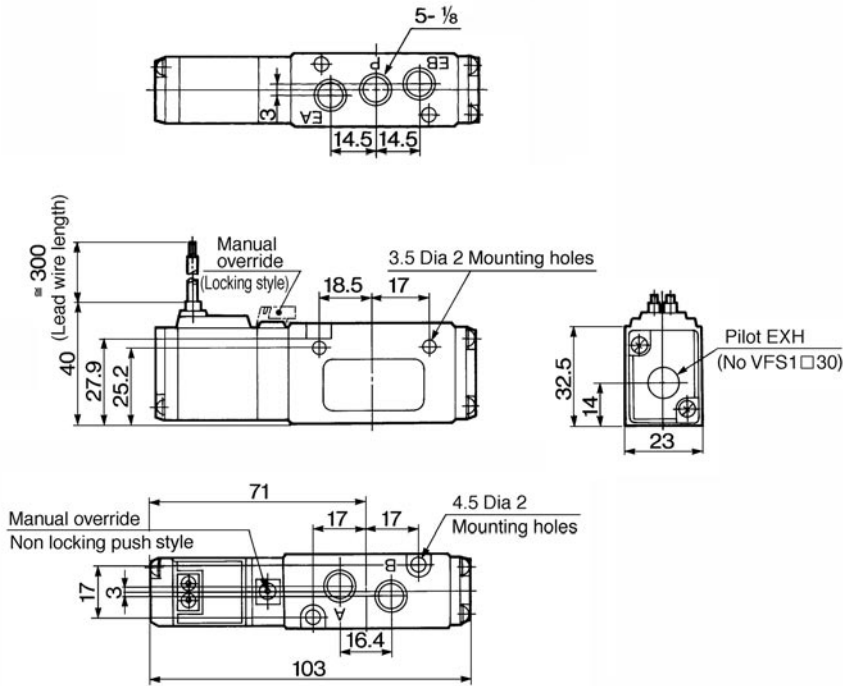

With bracket (F):
AXT626-10A

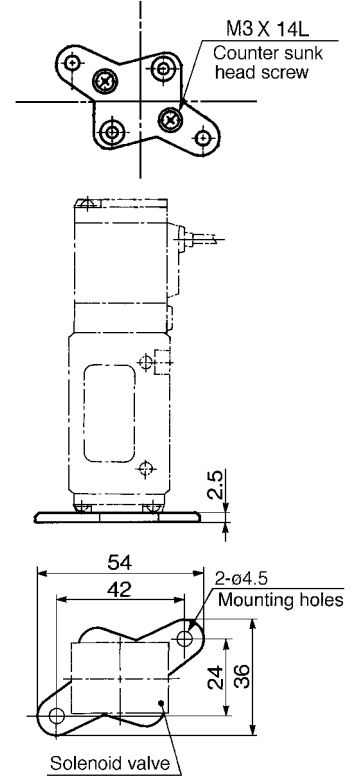

Grommet terminal: VFS1120-□E, EZ

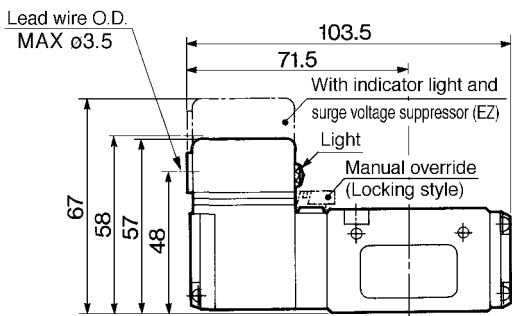

DIN connector: VFS1120-□D, DZ

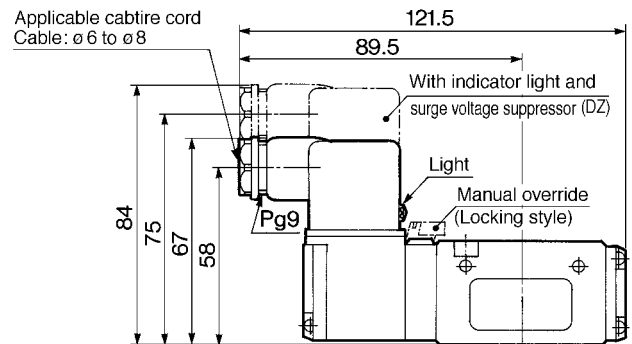

Conduit terminal: VFS1120-□T, TZ

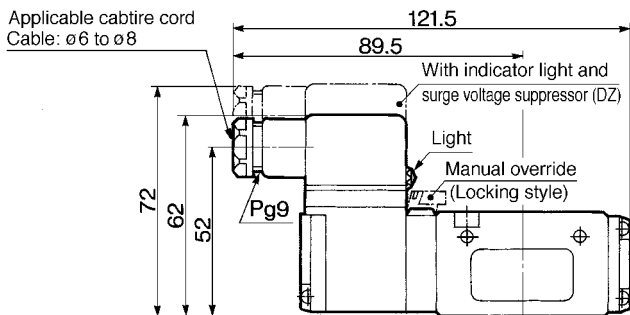

2 Position Double, 3 Position DIN Connector

Grommet: VFS1220-□G, VFS1320-□G, VFS1420-□G, VFS1520-□G

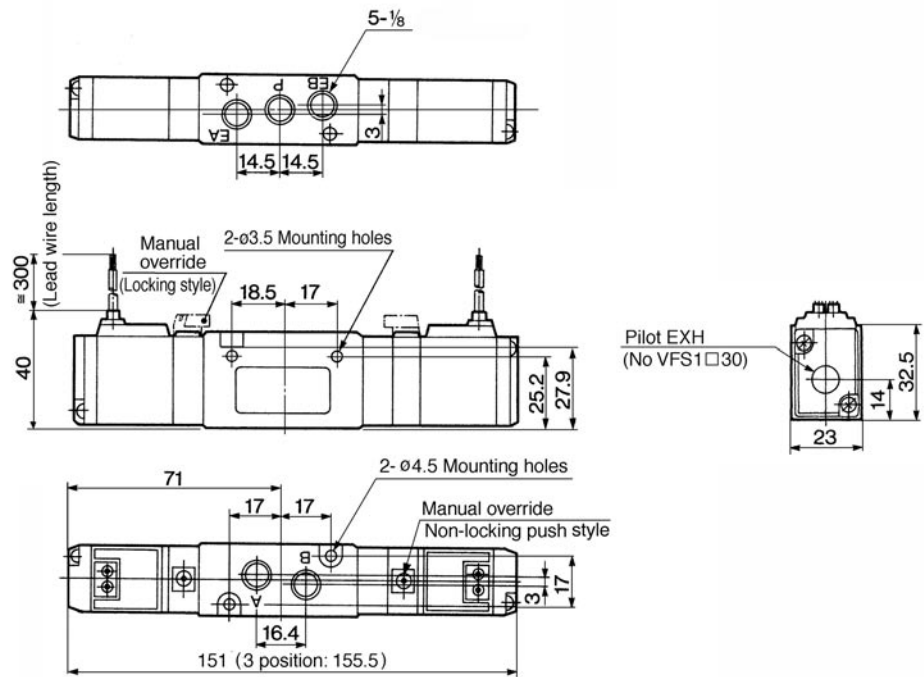

Grommet terminal: VFS1220-□E, EZ VFS1320-□E, EZ
 VFS1420-□E, EZ
 VFS1520-□E, EZ

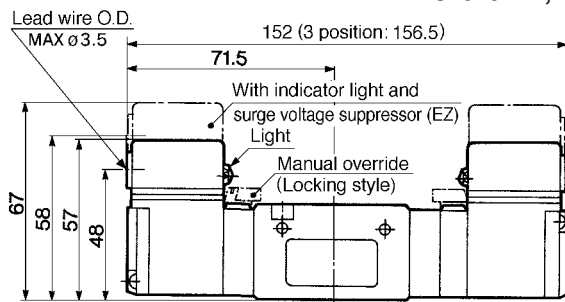

DIN connector: VFS1220-□D, DZ VFS1320-□D, DZ
 VFS1420-□D, DZ
 VFS1520-□D, DZ

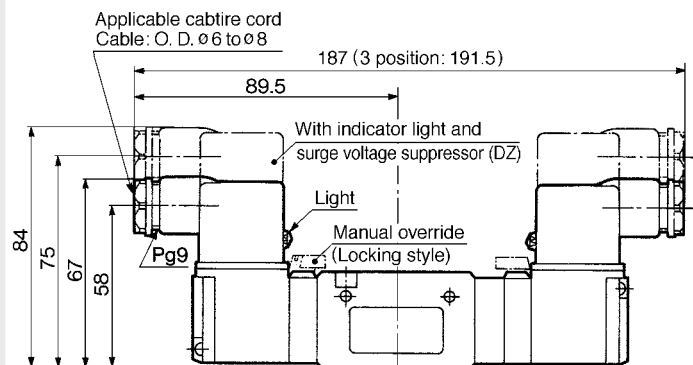

Conduit terminal: VFS1220-□T, TZ VFS1320-□T, TZ
 VFS1420-□T, TZ
 VFS1520-□T, TZ

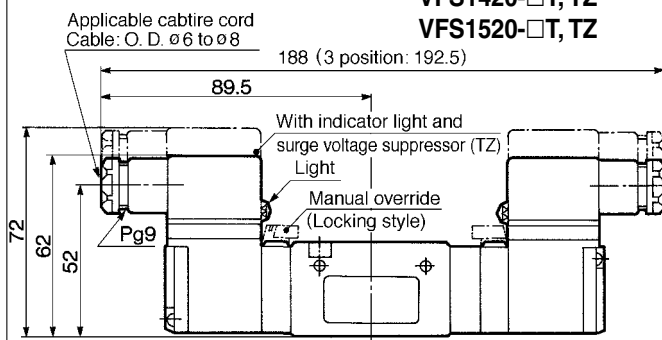

Series VFS1000 Manifold/Bar Style

Compact and lightweight

Compact due to manifolding on a single base for mounting in small spaces.

Protection of the environment from pilot exhaust

Use of the VV5FS1-30 manifold can exhaust intensively the pilot exhaust gas to the base side, and can prevent environmental aggravation due to noise and oil mist.



VV5FS1-20

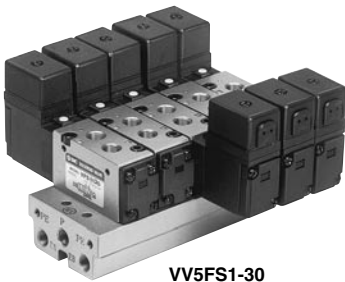

VV5FS1-30

Specifications

Manifold base	Bar manifold, Body ported
Stations	Max. 15

Port Specifications

Symbol	Port specification		Porting specification (Connecting port size)		
	P	EA, EB	Base	Valve	Base
1	Common	Common	Side/ 1/8	Top/ 1/8	Side/1/8

Option

Blank plate assembly	VVFS1000-10A-1	With gasket, screws
----------------------	----------------	---------------------

How to Order Manifold Base

VV5FS1
-20
-05
1
-01

-Q

Series VFS1000 Manifold
Ordering source area code

Code	areas
-	Japan, Asia Australia
E	Europe
N	North America

Stations

02	2 stations
⋮	⋮
15	15 stations

Thread

-	Rc (PT)
N	NPT
T	NPTF
F	G (PF)

Symbol

Symbol	Port specifications		Porting specifications
	P	EA, EB	
1	Common 1/8	Common 1/8	Top porting 1/8

Base Model

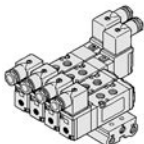
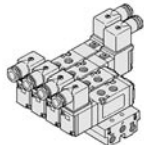
Type	Pilot exhaust	Applicable valve
20	Individual EXH 	VFS1□20-□□-01
30	Common EXH 	VFS1□30-□□-01 *VFS1□20-□□-01 mountable

How to Order Manifold Base Assembly

Please indicate manifold base style, valve model, and blank plate.

<<Example>>

(Manifold base style)	VV5FS1-20-061-01-Q	1
(2 position single)	VFS1120-1D-01-Q	3
(2 position double)	VFS1220-1D-01-Q	2
(Blank plate)	VVFS1000-10A-1	1

20 Type Manifold Pilot Individual Exhaust: VVFS1-20-Station 1-01

Grommet: G

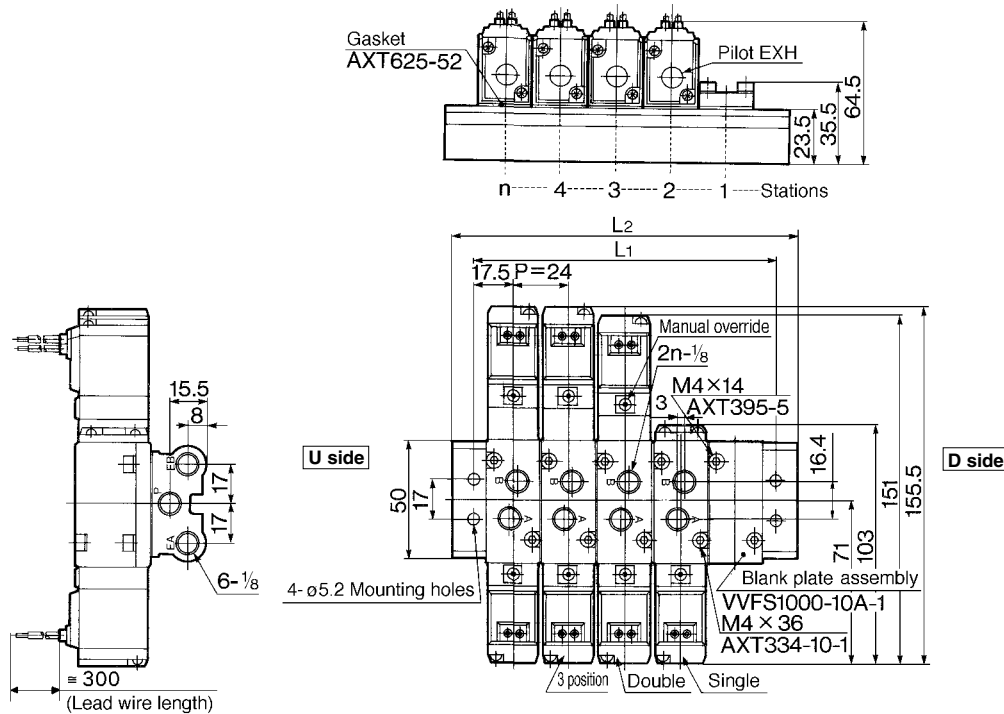

General formula of weight/Manifold $M=0.049n+0.059$ (kg) n: Station

Grommet terminal: E, EZ

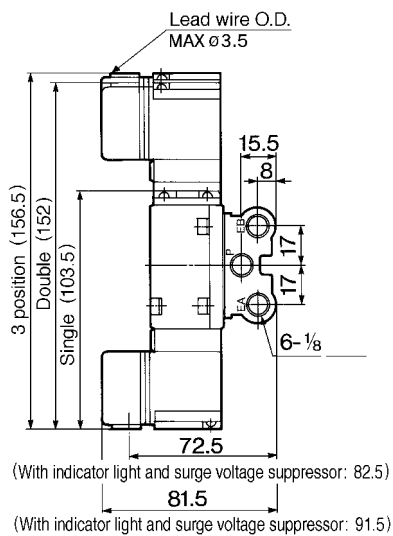

Conduit terminal: T, TZ

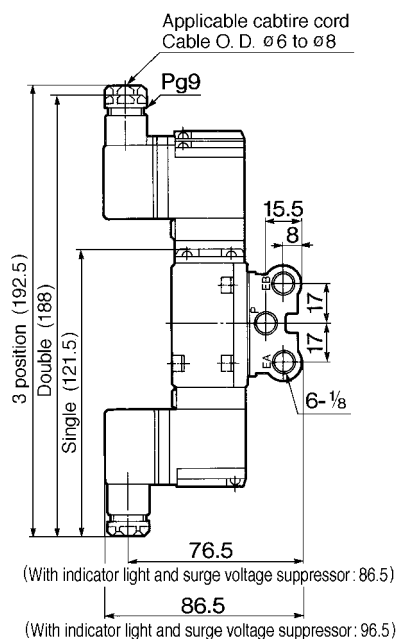

DIN connector: D, DZ

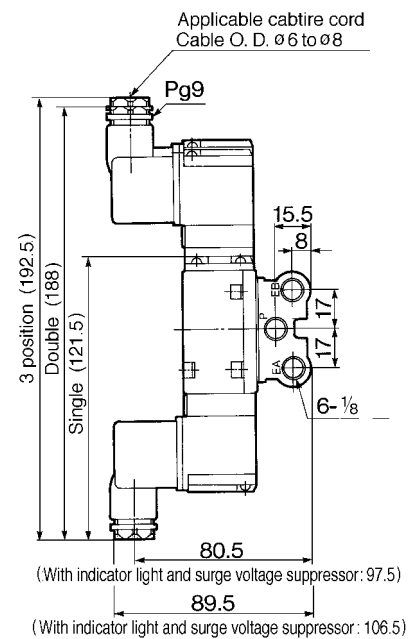

n: Station

L	n	2	3	4	5	6	7	8	9	10	Equation
L1		59	83	107	131	155	179	203	227	251	$L1=24 \times n+11$
L2		77	101	125	149	173	197	221	245	269	$L2=24 \times n+29$

VFS1000

30 Type Manifold Pilot Individual Exhaust: VV5FS1-30- Station 1-01

Grommet: G

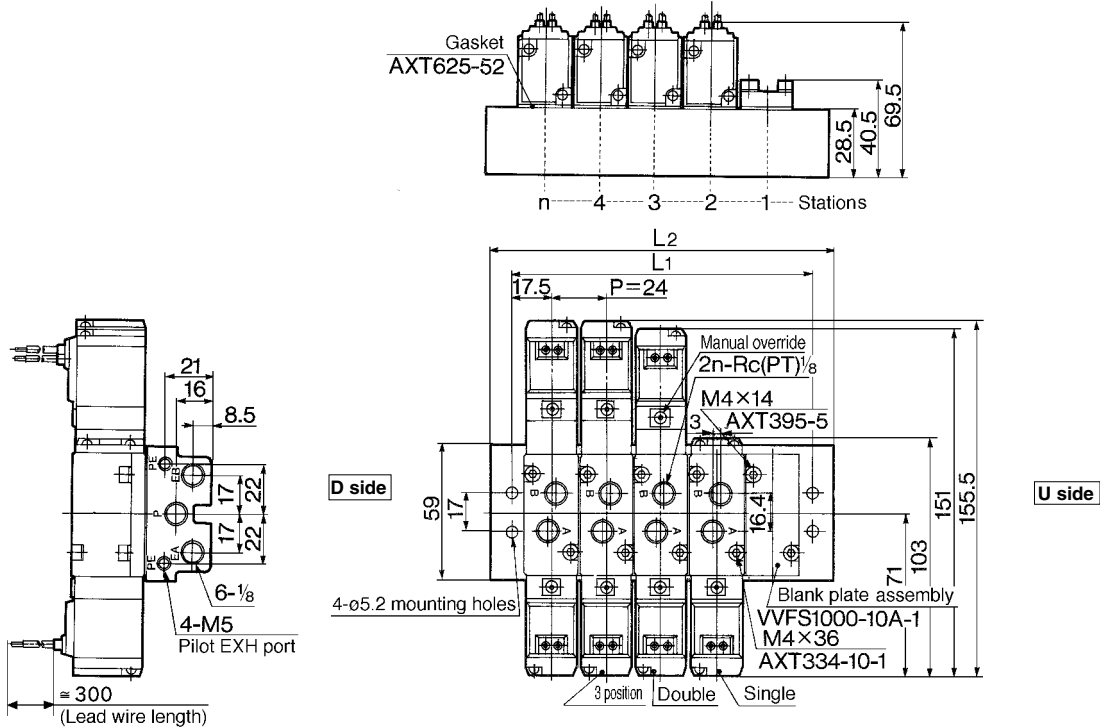

General formula of weight/Manifold $M=0.079n+0.093$ (kg) n: Station

Grommet terminal: E, EZ

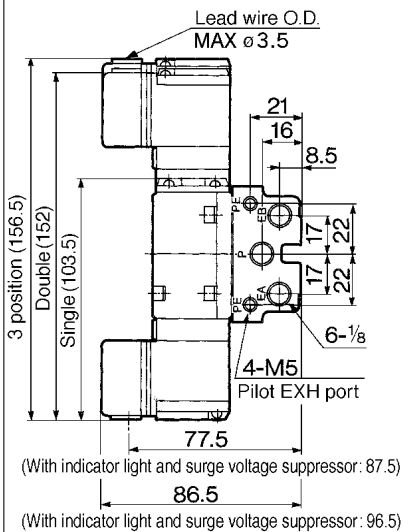

Conduit terminal: T, TZ

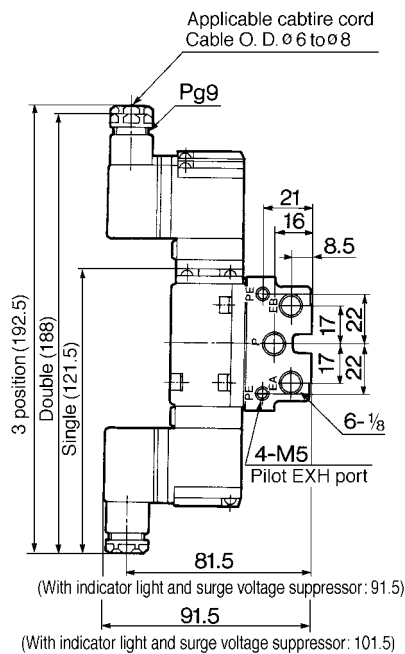

DIN connector: D, DZ

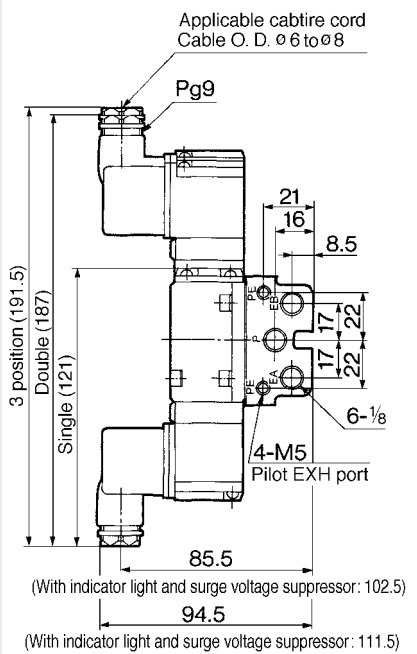

n: Station

L	n	2	3	4	5	6	7	8	9	10	Equation
L1		59	83	107	131	155	179	203	227	251	$L1=24 \times n+11$
L2		77	101	125	149	173	197	221	245	269	$L2=24 \times n+29$

5 Port Pilot/Metal Seal Body Ported Series VFS2000

**Compact and Large Flow
Capacity 1/4: Cv 1.0
Small Power Consumption/
1.8 W DC**



Model

Configuration		Model		Port size	Effective area (mm ²) (N _z /min)	Max. operating cycle (CPM) ⁽¹⁾	Response time (ms) ⁽²⁾	Weight (kgf) ⁽³⁾
2 position	Single	VFS2120	VFS2130	1/8	16.2 (883)	1200	22 or less	0.26
				1/4	18 (981)			
	Double	VFS2220	VFS2230	1/8	16.2 (883)	1200	13 or less	0.35
				1/4	18 (981)			
3 position	Closed centre	VFS2320	VFS2330	1/8	16.2 (883)	600	40 or less	0.42
				1/4	18 (981)			
	Exhaust centre	VFS2420	VFS2430	1/8	16.2 (883)	600	40 or less	0.42
				1/4	18 (981)			
	Pressure centre	VFS2520	VFS2530	1/8	16.2 (883)	600	40 or less	0.42
				1/4	18 (981)			



Note 1) According to JISB8375 (Once per 30 days) for the minimum operating frequency.
Note 2) According to JISB8375-1981. (The value at supply pressure 0.5MPa.)
Note 3) In case of a grommet. Note 4) Factors of "Note 1)" and "Note 2)" are achieved in controlled clean air.

Standard Specifications

Valve	Fluid		Air and inert gas	
	Max. operating pressure		1.0MPa	
	Min. operating pressure		0.1MPa	
	Proof pressure		1.5MPa	
	Ambient and fluid temperature		-10 to 60°C ⁽¹⁾	
	Lubrication		Not required ⁽²⁾	
	Pilot valve manual override		Non-locking push style (Flush)	
	Shock/vibration resistance		150/50m/s ² ⁽³⁾	
	Protection structure		Dust proof ⁽⁴⁾	
	Solenoid	Rated voltage		100V, 200V AC (50/60Hz), 24V DC
Allowable voltage		-15 to +10% rated voltage		
Coil insulation		Class B or equivalent (130°C) ⁽⁵⁾		
Apparent power (Power consumption)		AC	Inrush	5.6VA (50Hz), 5.0VA (60Hz)
			Holding	3.4VA (2.1W)/50Hz, 2.3VA (1.5W)/60Hz
Power consumption DC		1.8W		
Electrical entry		DIN connector		



Note 1) Use dryair at low temperatures.
Note 2) Use turbine oil No. 1 (ISO VG 32), if lubricated.
Note 3) Shock resistance: No malfunction from test using drop impact tester to axis and right angle directions of main valve and armature, each one time when energized and de-energized. (Value in the initial stage.)
Vibration resistance: No malfunction from test with 8.3 to 2000Hz 1 sweep, to axis and right angle directions of main valve and armature, each one when energized and de-energized. (Value in the initial stage.)
Note 4) According to JIS C0920. Note 5) According to JIS C4003.

JIS Symbol

2 position	3 position
Single	Closed centre
Double	Exhaust centre
	Pressure centre

Option Specifications

Pilot style	Outside pilot ⁽¹⁾
Manual override	Non-locking push style (Extended), Locking style (Slotted)
Voltage	110 to 120V, 220V, 240V AC (50/60Hz)
	12V, 100V DC
Option	With indicator light and surge voltage suppressor ⁽²⁾
Foot bracket (with screw)	Part No. VFN200-17A, VFS2120 (single) only



Note 1) Operating pressure: 0 to 1.0MPa. Pilot operating pressure: 0.1 to 1.0MPa.
Note 2) No light grommet but surge voltage suppressor (direct connecting lead wire) is installed.

Manifold

Valve model	Applicable manifold base (Pilot EXH)
VFS2□20	Bar manifold (Individual EXH)
VFS2□30	Bar manifold (Common EXH. base side)



Note) VFS2□30: Manifold only, and cannot be used as a single unit.

VFS2000

How to Order

VFS2 **1** **20** **1** **D** **01** **Q**

Ordering source area code

Code	
-	Japan, Asia Australia
E	Europe
N	North America

Configuration

1: 2 position single

2: 2 position double

3: 3 position closed centre

4: 3 position exhaust centre

5: 3 position pressure centre

*Reverse pressure:
Can be used by external pilot specification.

Body (Pilot exhaust)

20: Individual EXH

30: Common EXH*

*Manifold only.

Port size

01	1/8
02	1/4

Thread

-	Rc (PT)
N	NPT
T	NPTF
F	G (PF)

Optional accessory

F: Foot bracket

*Only for VFS2120.

Manual override

-	Non-locking push style (Flush)	A: Non-locking push style (Extended)*	B: Locking style (Slotted)*
---	--------------------------------	---------------------------------------	-----------------------------

*Option

Indicator light/surge voltage suppressor

-	None
Z	With indicator light and surge voltage suppressor

Electrical entry

D: DIN connector	Y: DIN connector (DIN 43650)
DO: Without connector	YO: Without DIN connector

Voltage

1	100V AC (50/60Hz)
2	200V AC (50/60Hz)
3	110V to 120V AC (50/60Hz)
4	220V AC (50/60Hz)
5	24V DC
6	12V DC
7	240V AC (50/60Hz)
9	Other,(250V or less)

Pilot

-	Internal
R*	External

*Option
Individual external pilot (External pilot port: Body side)

Order Note
Contact SMC for other voltages (9)

How to Order Pilot Valve Assembly

SF4 **1** **DZ** **12** **Q**

Voltage

1	100V AC 50/60Hz
2	200V AC 50/60Hz
3*	110 to 120V AC (50/60Hz)
4*	220V AC 50/60Hz
5	24V DC
6*	12V DC
7*	240V AC 50/60Hz
9*	Other

*Option

Electrical entry/Indicator light and surge voltage suppressor

D	DIN connector
DZ	DIN connector with indicator light and surge suppressor
DO	DIN connector*
DOZ	DIN connector with indicator light and surge suppressor*
Y	DIN connector (DIN 43650B)
YO	DIN connector (DIN 43650B)*

*Without DIN connector

Manual override

-	Non-locking push style (Flush)
A*	Non-locking push style (Extended)
B*	Non-locking push style (Extended)

*Option

Applicable model

12	For VFS2□20	Individual pilot exhaust
13	For VFS2□30	Common pilot exhaust

Maximum Cylinder Speed

Conditions: Supply pressure 0.5MPa Load factor 50%, Stroke 100mm

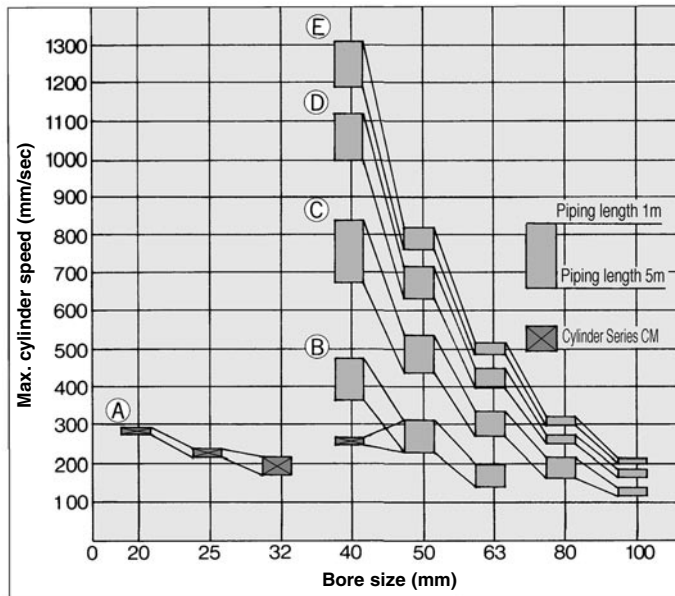

System diagram

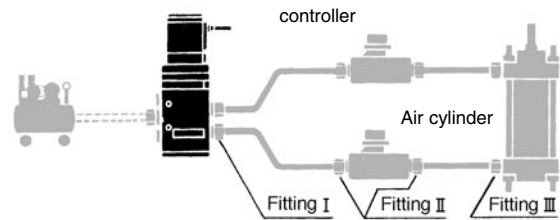

System	Solenoid valve	Port size	Nylon tube O.D./I.D.	Silencer	Speed Controller
A	VFS2120-02	1/4	ø4/3	AN110-01	AS2000-01
B	VFS2120-02	1/4	ø6/4.5	AN110-01	AS4000-02
C	VFS2120-02	1/4	ø8/6	AN110-01	AS4000-02
D	VFS2120-02	1/4	ø10/7.5	AN110-01	AS4000-02
E	VFS2120-02	1/4	ø12/9	AN110-01	AS4000-02

Construction

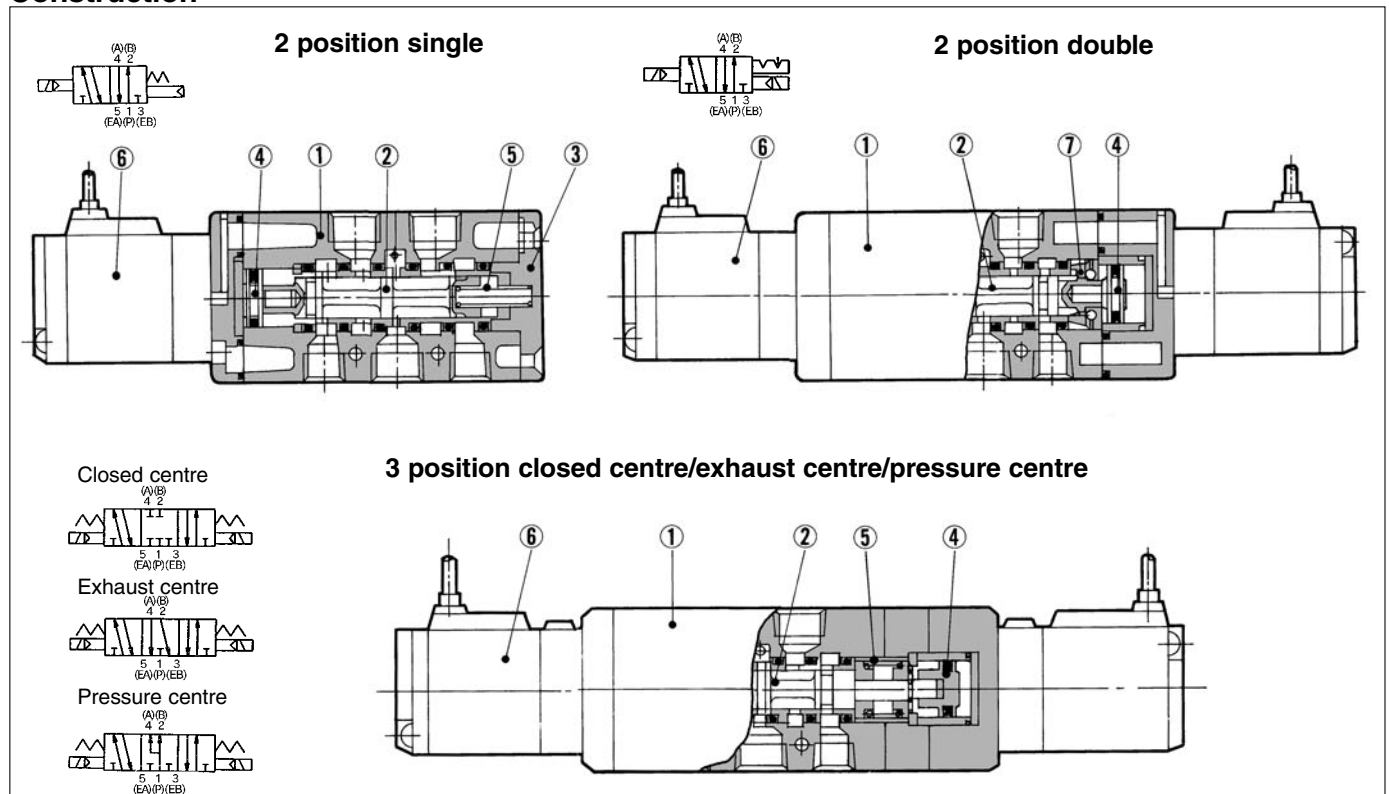

Component Parts

No.	Description	Material	Note
①	Body	Aluminium die-cast	Platinum silver
②	Spool/Sleeve	Stainless steel	—
③	End plate	Resin	—
④	Piston	Resin	—

Replacement Parts

No.	Description	Material	Part No.		
			VFS2120	VFS2220	VFS2320, 2420, 2520
⑤	Return spring	Stainless steel	VFS2000-17-1	—	VFS2000-17-2
⑥	Pilot valve assembly	—	Refer to "How to order/Pilot valve assembly" on p.1.17-18.		
⑦	Detent assembly	—	—	VFN2000-8A	—

VFS2000

2 Position Single DIN Connector

Grommet: VFS2120-□G

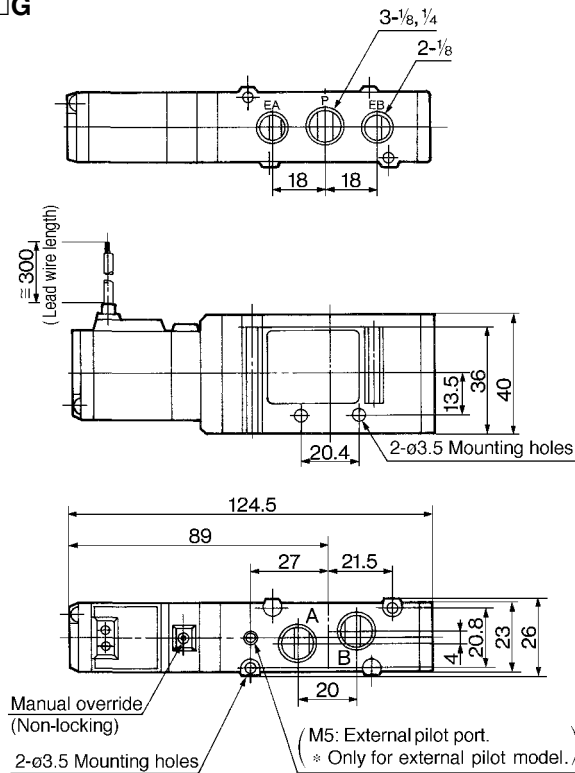

Foot bracket (F): VFN200-17A

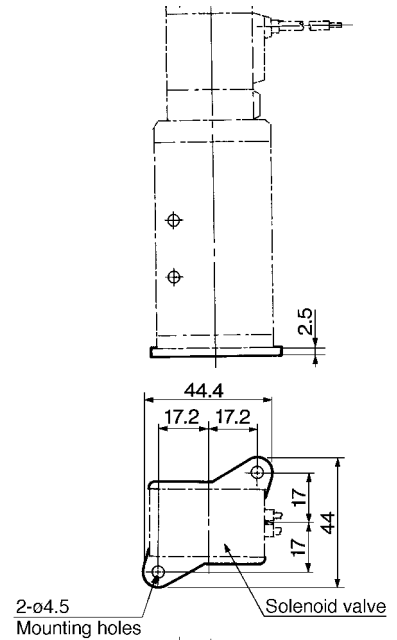

Grommet terminal: VFS2120-□E, EZ

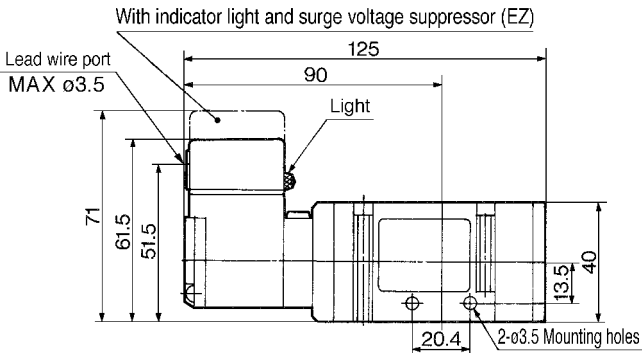

DIN connector: VFS2120-□D, DZ

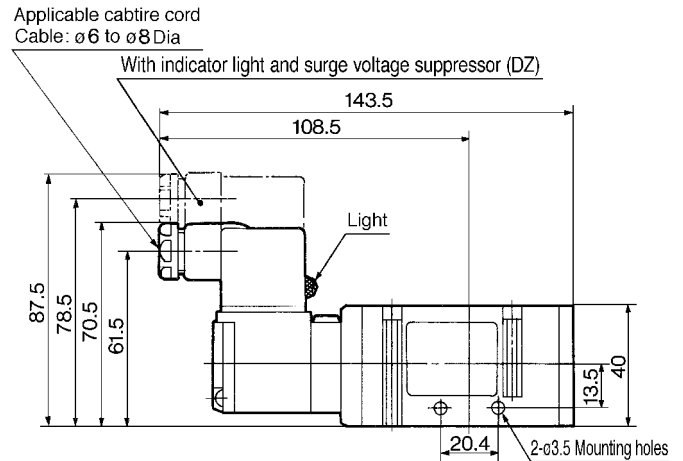

Conduit terminal: VFS2120-□T, TZ

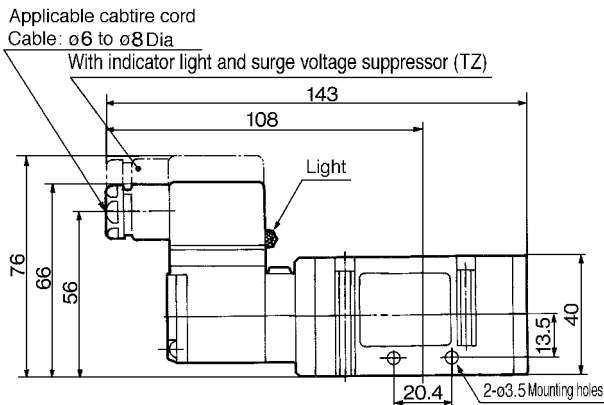

2 Position Double, 3 Position DIN Connector

Grommet: VFS2220-□G, VFS2320-□G, VFS2420-□G, VFS2520-□G

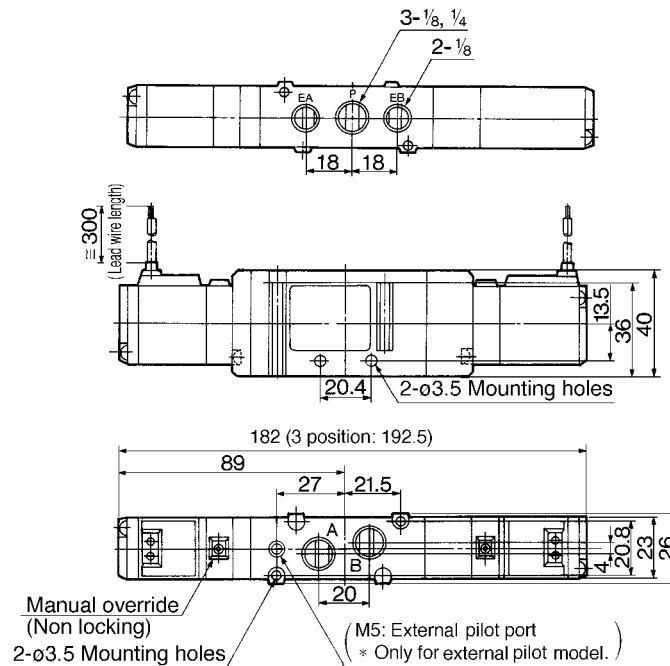

Grommet terminal: VFS2220-□E, EZ VFS2320-□E, EZ
VFS2420-□E, EZ VFS2520-□E, EZ

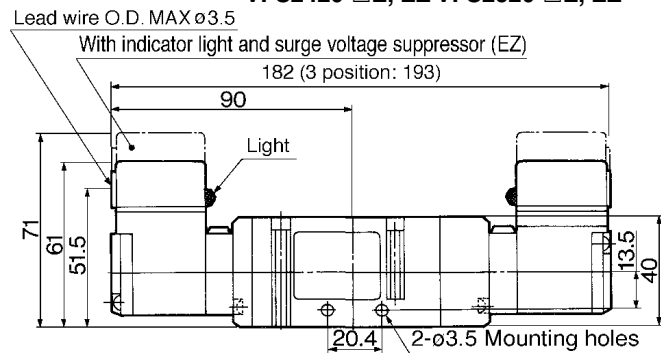

DIN connector: VFS2220-□D, DZ VFS2320-□D, DZ
VFS2420-□D, DZ VFS2520-□D, DZ

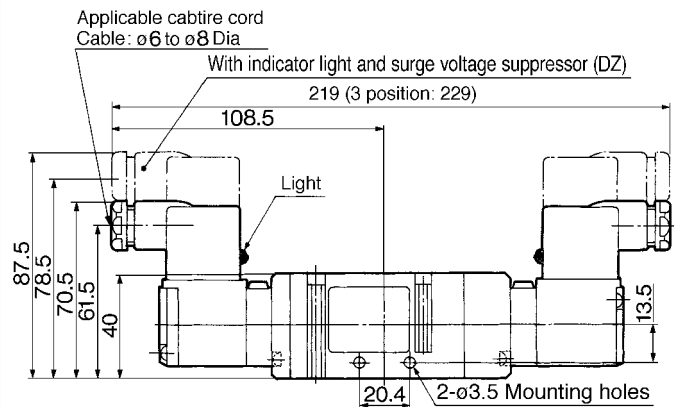

Conduit terminal: VFS2220-□T, TZ VFS2320-□T, TZ
VFS2420-□T, TZ VFS2520-□T, TZ

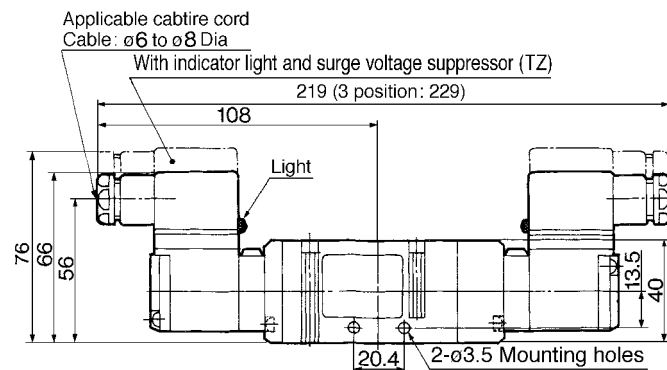

Series VFS2000 Manifold/Bar Style

Protection of the environment from pilot exhaust

Use of the VV5FS2-30 manifold can exhaust intensively the pilot exhaust gas to the base side, and can prevent environmental aggravation due to noise and oil mist.

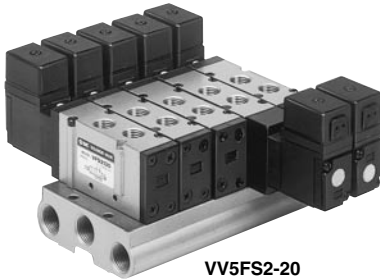

VV5FS2-20

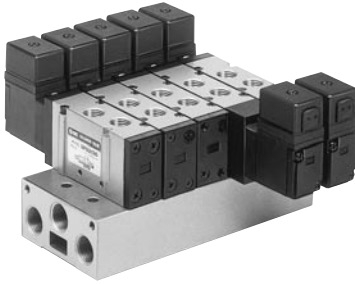

VV5FS2-30

Specifications

Manifold base	Bar manifold, Body ported
Stations	Max. 15

Port Specifications

Symbol	Port specification		Porting specification:		
	P	EA, EB	Base	Valve	Base
1	Common	Common	Side: 3/8	Top: 1/8, 1/4	Side: 3/8

Options

Blank plate assembly	VVFS2000-10A-1	With gasket, screws
----------------------	----------------	---------------------

How to Order Manifold Base

VV5FS2-20-05-1-03-Q

Series VFS2000 Manifold

Ordering source area code

Code	areas
-	Japan, Asia Australia
E	Europe
N	North America

Thread

—	Rc (PT)
N	NPT
T	NPTF
F	G (PF)

P, EA, EB Port size
03-3/8

Symbol

	Port specification		Porting spec.
	P	EA, EB	A, B
1	Common 3/8	Common 3/8	Top porting 1/8 1/4

Stations

02	2 stations
⋮	⋮
15	15 stations

Base Model

How to Order Manifold Base Assembly

Please indicate manifold base style, valve model, and blank plate.

<<Example>>

(Manifold base)	VV5FS2-20-061-03-Q	1
(2 position single)	VFS2120-1D-02-Q	3
(2 position double)	VFS2220-1D-02-Q	2
(Blank plate)	VVFS2000-10A-1	1

Type	Pilot exhaust	Applicable valve
20	Individual EXH 	VFS2□20-□□-01
30	Common EXH 	VFS2□30-□□-01 *VFS2□20-□□-01 can be attached.

20 Type Manifold Pilot Individual Exhaust: VVFS2-20- Station 1-03

Grommet: G

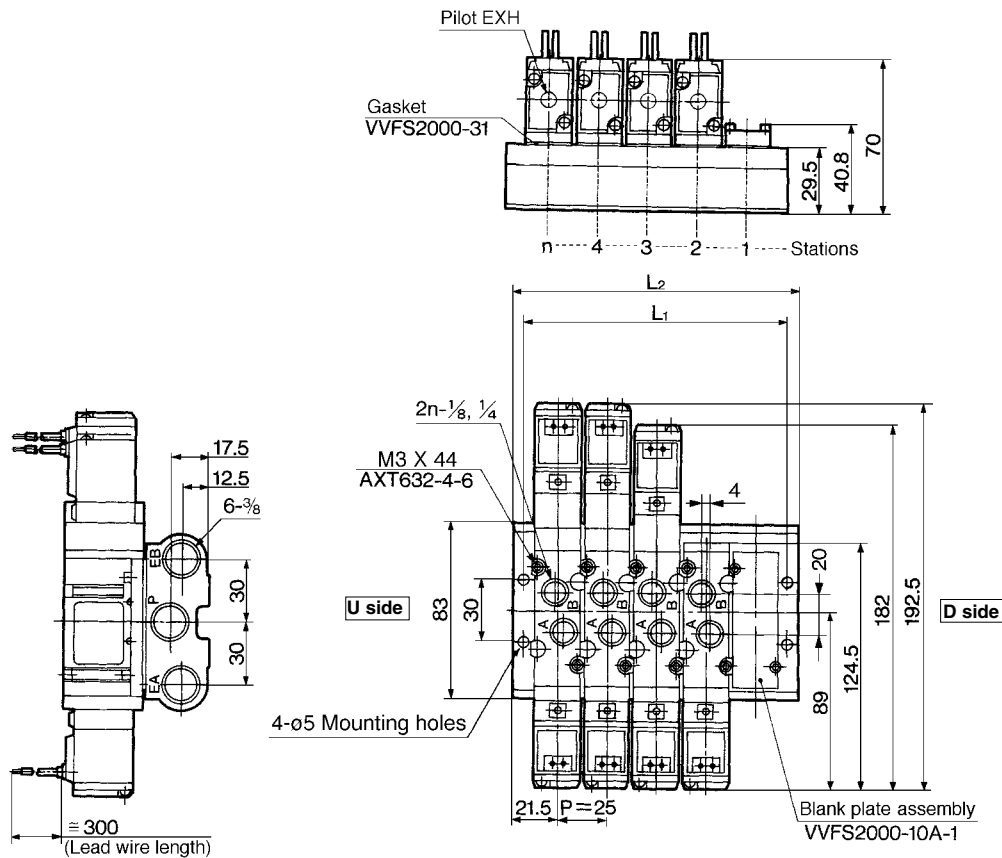

General formula of weight/Manifold $M=0.108n+0.068$ (kg) n: Station

Grommet terminal: E, EZ

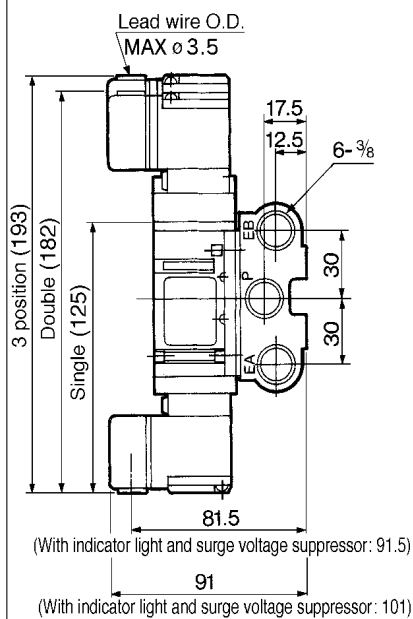

Conduit terminal: T, TZ

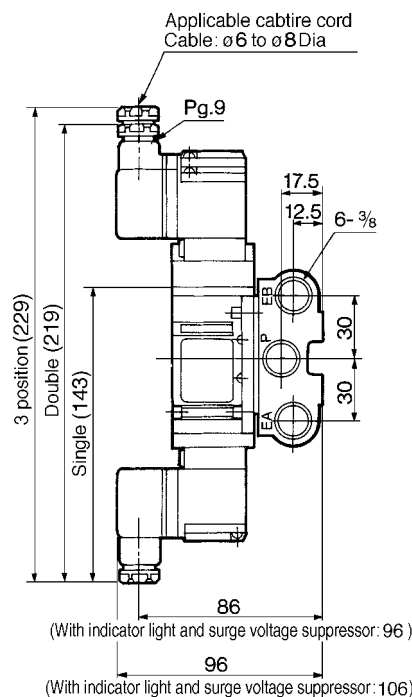

DIN connector: D, DZ

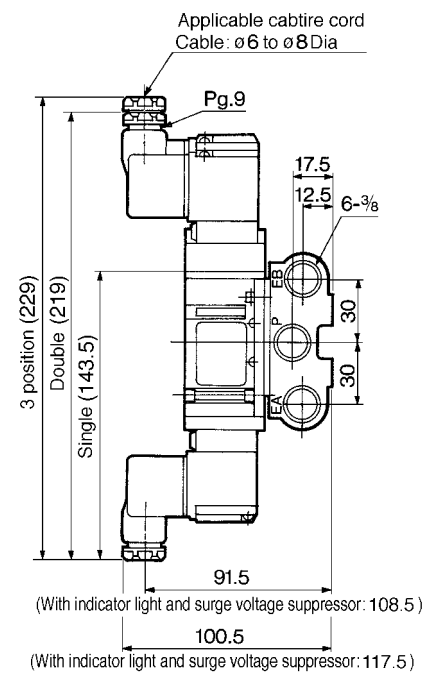

n: Station

L	n	2	3	4	5	6	7	8	9	10	Equation
L1		58	83	108	133	158	183	208	233	258	$L1=25 \times n+8$
L2		68	93	118	143	168	193	218	243	268	$L2=25 \times n+18$

30 Type Manifold Pilot Common Exhaust: VVFS2-30- Station 1-03

Grommet: G

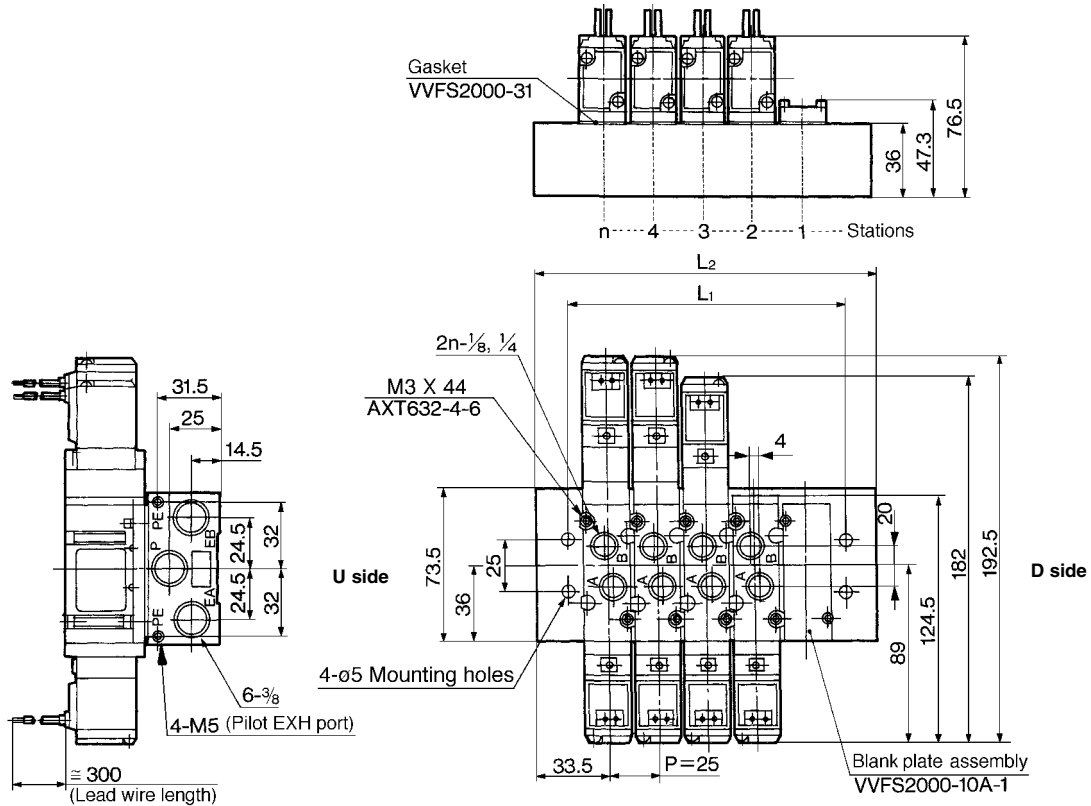

General formula of weight/Manifold $M=0.12n+0.21$ (kg) n: Station

Grommet terminal: E, EZ

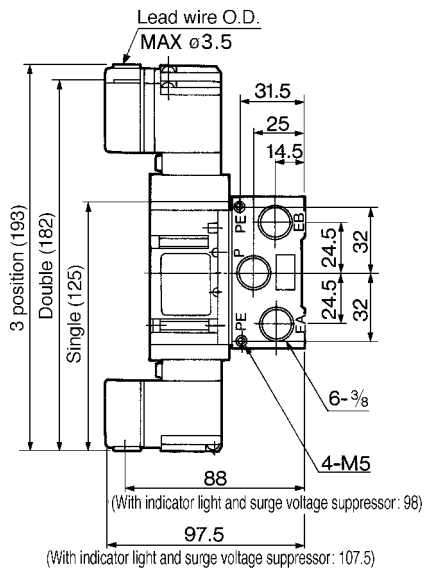

Conduit terminal: T, TZ

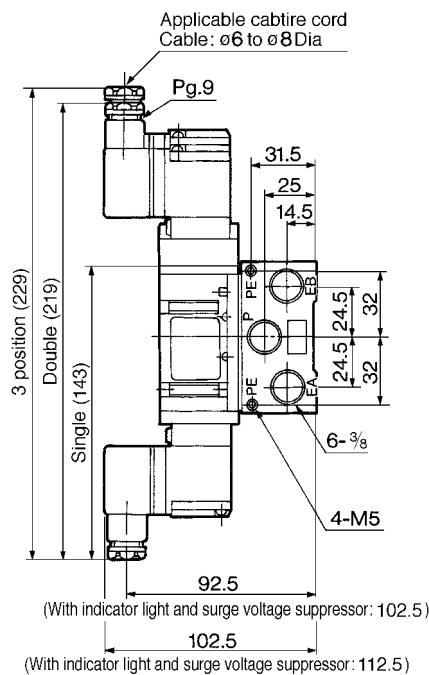

DIN connector: D, DZ

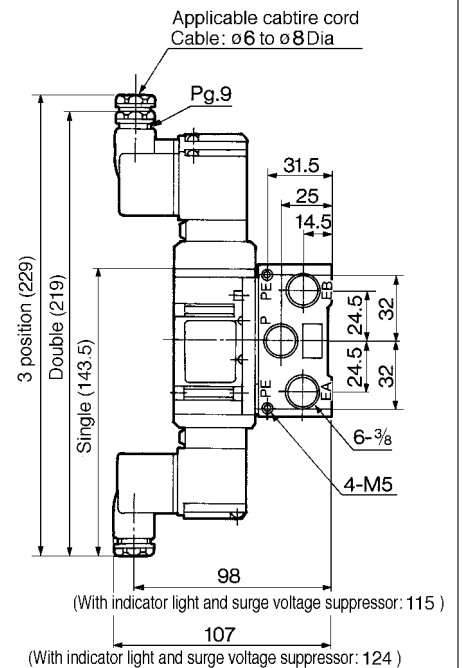

n: Station

L	n	2	3	4	5	6	7	8	9	10	Equation
L1		62	87	112	137	162	187	212	237	262	$L1=25 \times n+12$
L2		92	117	142	167	192	217	242	267	292	$L2=25 \times n+42$

5 Port Pilot/Metal Seal Body Ported Series VFS3000

Compact and Large Flow
Capacity 3/8: Nl/min 1963
Small Power Consumption/
1.8 W DC



Model

Configuration		Model		Port size	Effective area (mm ²) (Nl/min)	Max. operating cycle (CPM) ⁽¹⁾	Response time (ms) ⁽²⁾	Weight (kgf) ⁽³⁾
2 position	Single	VFS3120	VFS3130	1/4	34.2 (1865)	1200	20 or less	0.33
				3/8	36.0 (1963)			
	Double	VFS3220	VFS3230	1/4	34.2 (1865)	1500	15 or less	0.43
				3/8	36.0 (1963)			
3 position	Closed centre	VFS3320	VFS3330	1/4	32.4 (1767)	600	40 or less	0.45
				3/8	36.0 (1963)			
	Exhaust centre	VFS3420	VFS3430	1/4	32.4 (1767)	600	40 or less	0.45
				3/8	36.0 (1963)			
	Pressure centre	VFS3520	VFS3530	1/4	32.4 (1767)	600	40 or less	0.45
				3/8	36.0 (1963)			



Note 1) According to JISB8375 (Once per 30 days) for the minimum operating frequency.

Note 2) According to JISB8375-1981. (The value at supply pressure 0.5MPa.)

Note 3) In case of a grommet. Note 4) Factors of "Note 1)" and "Note 2)" are achieved in controlled clean air.

Standard Specifications

Fluid		Air and inert gas	
Max. operating pressure		1.0MPa	
Min. operating pressure		0.1MPa	
Proof pressure		1.5MPa	
Valve	Ambient and fluid temperature		-10 to 60°C ⁽¹⁾
	Lubrication		Not required ⁽²⁾
	Pilot valve manual override		Non-locking push style (Flush)
	Shock/vibration resistance		150/50ms ² ⁽³⁾
	Protection structure		Dust proof ⁽⁴⁾
	Rated voltage		100V, 200V AC(50/60Hz), 24V DC
	Allowable voltage		-15 to +10% rated voltage
	Coil insulation		Class B or equivalent (130°C) ⁽⁴⁾
Solenoid	Apparent power (Power consumption) AC	Inrush	5.6VA/50Hz, 5.0VA/60Hz
		Holding	3.4VA (2.1W)/50Hz, 2.3VA (1.5W)/60Hz
	Power consumption		1.8W
	Electrical entry		DIN connector



Note 1) Use dry-air at low temperatures.

Note 2) Use turbine oil class 1 (ISO VG 32), if lubricated.

Note 3) Shock resistance: No malfunction from test using drop impact tester to axis and right angle directions of main valve and armature, each one time when energized and de-energized. (Valve in the initial stage.)

Vibration resistance: No malfunction from test with 8.3 to 2000Hz 1 sweep, to axis and right angle directions of main valve and armature, each one when energized and de-energized. (Value in the initial stage.)

Note 4) According to JIS C0920.

Note 5) According to JIS C4003.

JIS Symbol

2 position	3 position
Single	Closed centre
Double	Exhaust centre
	Pressure centre

Option Specifications

Pilot	Outside pilot ⁽¹⁾	
Manual override	Non-locking push style (Extended), Locking style (Slotted)	
Voltage	110 to 120V, 220V, 240V AC (50/60Hz)	
	12V, 100V DC	
Option	With indicator light and surge voltage suppressor ⁽²⁾	
Foot bracket (with screw)	Part No. VFS3000-52A, VFS3120 (single) only	



Note 1) Operating pressure: 0 to 1.0MPa
Pilot operating pressure: 0.1 to 1.0MPa

Note 2) No light for grommet but surge voltage suppressor (direct connecting lead wire) is installed.

Manifold

Valve model	Applicable manifold base	Pilot EXH
VFS3□20	Stacking manifold	Individual EXH (Valve side)
VFS3□30		Common EXH (Manifold base side)

VFS3000

How to Order

VFS3 1 20 1 D 02 Q

Ordering source area code

Code	areas
-	Japan, Asia Australia, England
E	Europe
N	North America

Configuration

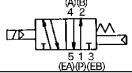
1: 2 position single

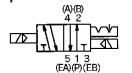
2: 2 position double

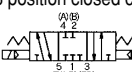
3: 3 position closed centre

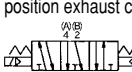

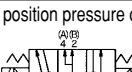
4: 3 position exhaust centre

5: 3 position pressure centre

*Reverse pressure: Can be used by external pilot specification.

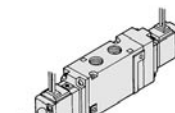
Body (Pilot exhaust)

20: Individual EXH

30: Common EXH*

*Manifold only.

Optional accessory

F: Foot bracket

 *Only for VFS3120.

Thread

	Rc (PT)
N	NPT
T	NPTF
F	G (PF)

Port size

02	1/4
03	3/8

Manual override

	A: Non-locking push style (Extended)*	B: Locking style (Slotted)*
-	Non-locking push style (Flush)	Locking style (Slotted)*

*Option

Indicator light/surge voltage suppressor

	None
Z	With indicator light and surge voltage suppressor

Electrical entry

	D: DIN connector	Y: DIN connector (DIN 43650)
DO	Without connector	Without DIN connector

Voltage

1	100V AC (50/60Hz)
2	200V AC (50/60Hz)
3	110V to 120V AC (50/60Hz)
4	220V AC (50/60Hz)
5	24V DC
6	12V DC
7	240V AC (50/60Hz)
9	Other, (250V or less)

Contact SMC for other voltages (9)

Pilot

	Internal
R*	External

*Option

External pilot port: Body side. For 30 type, common external pilot (on manifold side).

Protective class class I (Mark: )

How to Order Pilot Valve Assembly

SF4 1 DZ 14 Q

Voltage

1	100V AC 50/60Hz
2	200V AC 50/60Hz
3	110 to 120V AC (50/60Hz)
4	220V AC 50/60Hz
5	24V DC
6	12V DC
7	240V AC 50/60Hz
9	Other

Electrical entry/Indicator light and surge voltage suppressor

D	DIN connector
DZ	DIN connector with indicator light and surge suppressor
DO	DIN terminal*
DOZ	DIN connector with indicator light and surge suppressor*
Y	DIN connector (DIN 43650B)
YO	DIN connector (DIN 43650B)*

*Without DIN connector.

Manual override

-	Non-locking push style (Flush)
A*	Non-locking push style (Extended)
B*	Locking style (Lever)

*Option

Applicable model

14	A side pilot operator for VFS3 ¹ ₂ 20 ⁴ ₅	Individual pilot exhaust
15	B side operator for VFS3220	
16	B side operator for VFS3 ³ ₅ 30	Common pilot exhaust
17	A side operator for VFS3 ¹ ₂ 30 ⁴ ₅	
18	B side operator for VFS3230	
19	B side operator for VFS3 ³ ₅ 40	

Maximum Cylinder Speed

Rubber hose piping system

Conditions: Supply pressure 0.5MPa, Load factor 50%

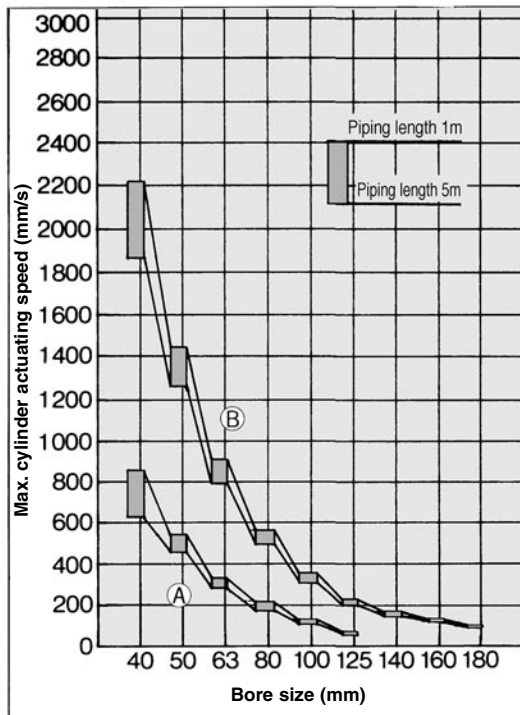

Steel tube piping system

Conditions: Supply pressure 0.5MPa, Load factor 50%

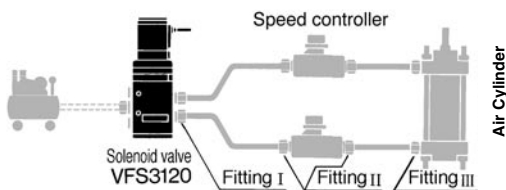
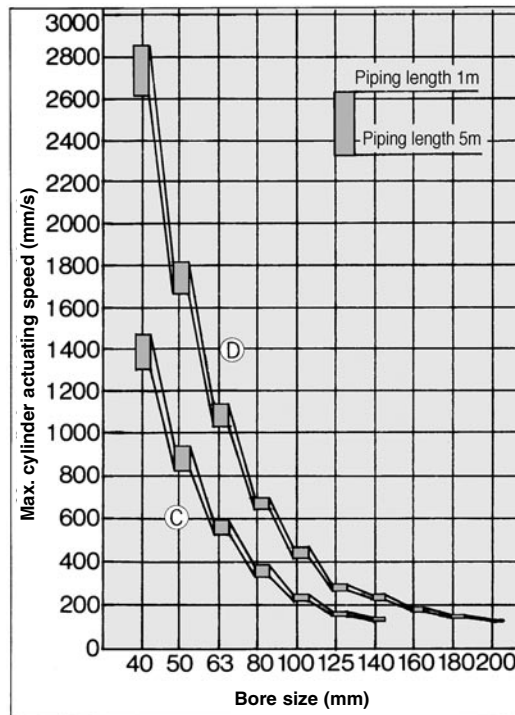

Rubber hose piping system

System	Solenoid valve	Speed controller	Silencer	Fitting
C	VFS3000-02 1/4	AS4000-02	AN200-02	90° Elbow 5pcs.
D	VFS3000-03 3/8	AS420-03		90° Elbow 5pcs.

Steel tube piping system

System	Solenoid valve	Speed controller	Silencer	Fitting (Hose I. D. X Fitting I. D. X port size)
A	VFS3000-02 1/4	AS4000-02	AN200-02	ø6.3 X ø4.8 X 1/4
B	VFS3000-03 3/8	AS420-03		ø9.5 X ø8 X 3/8

VFS3000

Construction

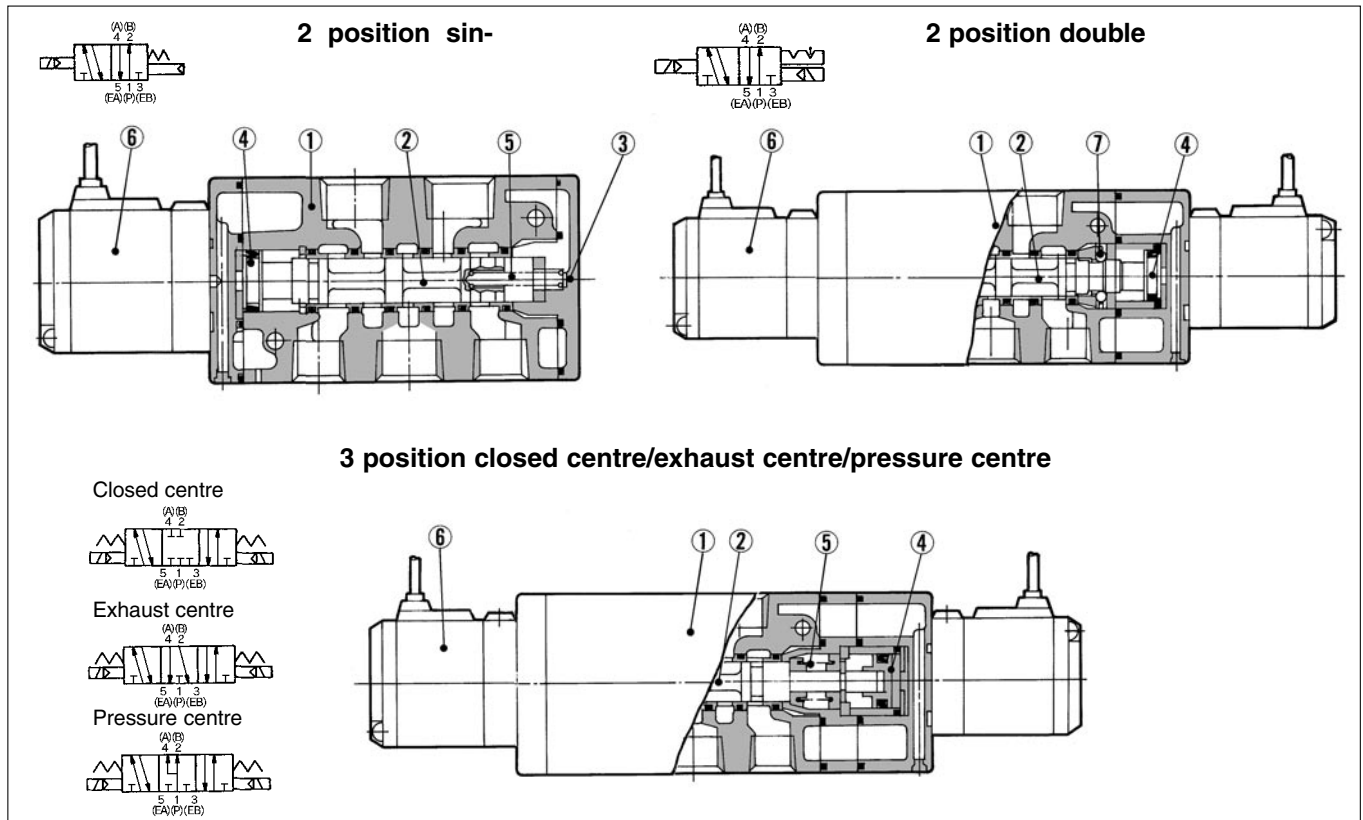

Component Parts

No.	Description	Material	Note
①	Body	Aluminium die-cast	Platinum silver
②	Spool/Sleeve	Stainless steel	—
③	End plate	Resin	Black
④	Piston	Resin	—

Replacement Parts

No.	Description	Material	Part No.		
			VFS3120	VFS3220	VFS3320, 3420, 3520
⑤	Return spring	Stainless steel	VFS3000-17-1	—	VFS3000-17-2
⑥	Pilot valve assembly	—	Refer to "How to order/Pilot valve assembly" on p.1.17-26.		
⑦	Detent assembly	—	—	VFS3000-9A	—

2 Position Single DIN Connector

Grommet: VFS3120-□G

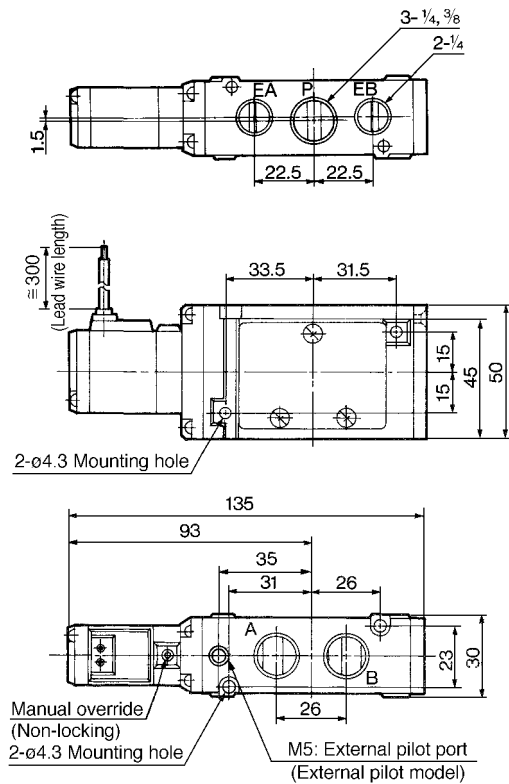

Foot bracket (F): VFS3000-52

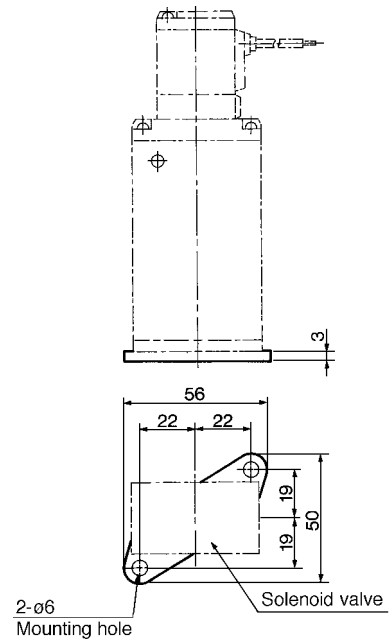

Grommet terminal: VFS3120-□E, EZ

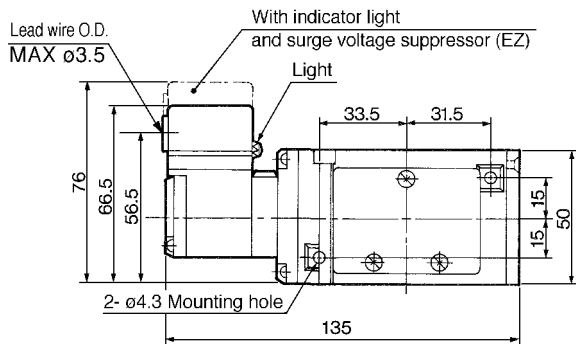

DIN connector: VFS3120-□D, DZ

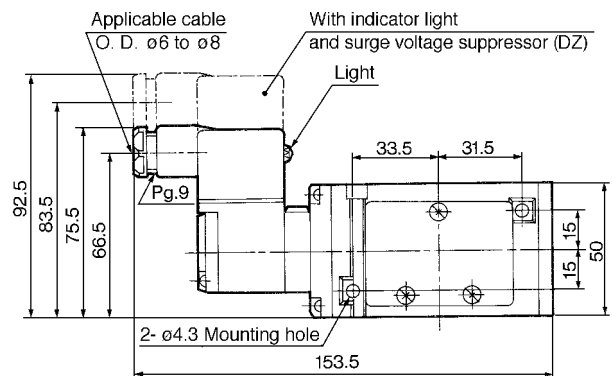

Conduit terminal: VFS3120-□T, TZ

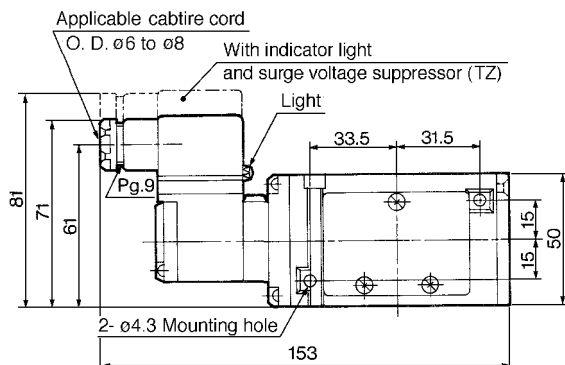

VFS3000

2 Position Double, 3 Position DIN Connector

Grommet: VFS3220-□G, VFS3320-□G, VFS3420-□G, VFS3520-□G

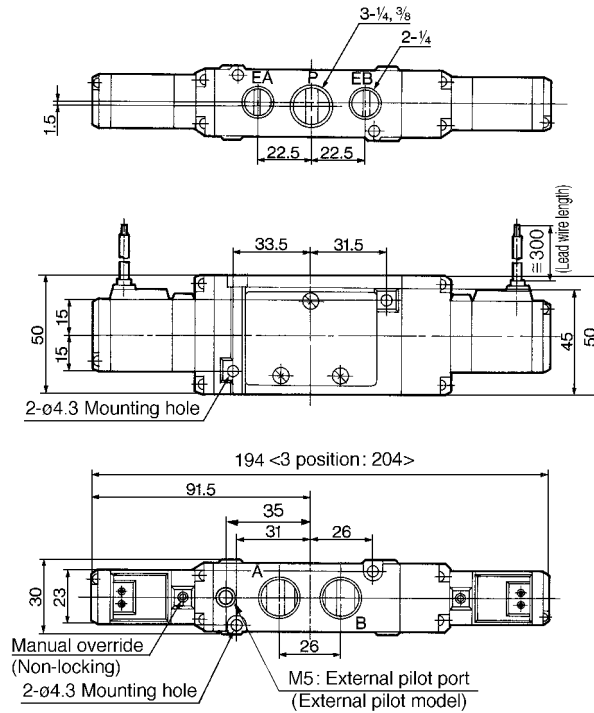

Grommet terminal: VFS3220-□E, EZ VFS3320-□E, EZ
VFS3420-□E, EZ VFS3520-□E, EZ

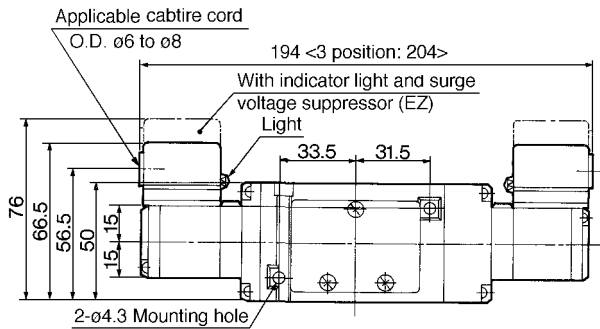

DIN connector: VFS3220-□D, DZ VFS3320-□D, DZ
VFS3420-□D, DZ VFS3520-□D, DZ

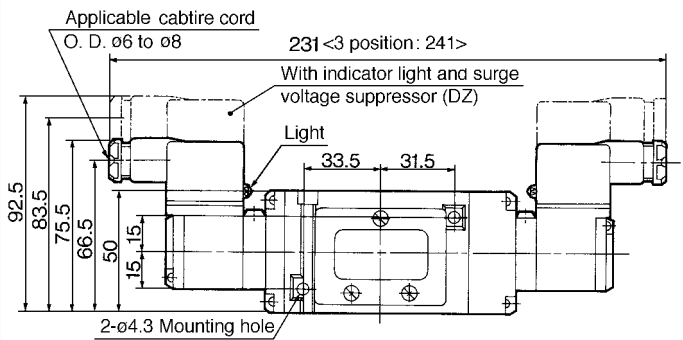

Conduit terminal: VFS3220-□T, TZ VFS3320-□T, TZ
VFS3420-□T, TZ VFS3520-□T, TZ

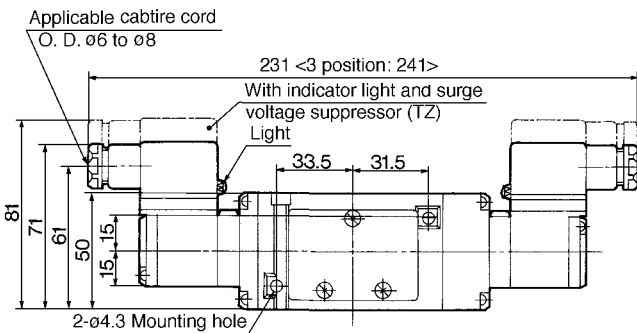

Series VFS3000

Manifold/stacking style

Keeps environmental air clean from pilot exhaust

Use of the VV5FS3-31 manifold can exhaust intensively the pilot exhaust gas to the base side, and can prevent environmental aggravation due to noise and oil mist.

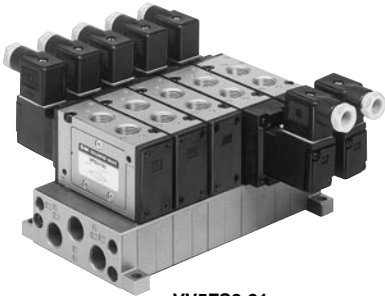

VV5FS3-31

Specifications

Manifold base style	Stacking
Stations	Max. 15

Port Specifications

Symbol	Port specification		Porting specification		
	P	EA, EB	Base	Valve	Base
1	Common	Common	Side: 3/8	Top: 1/4, 3/8	Side: 3/8

Options

Blank plate assembly	VVFS3000-10A-1	With gasket, screw
SUP block plate	AXT636-10A	-
EXH block plate	AXT636-11A	-

Note) Individual SUP or EXH is possible with bottom porting of SUP or EXH. For your order, please indicate it in the manifold specification.

How to Order Manifold Base

VV5FS3 - 31 - 05 1 - 03 - Q

- Series VFS3000 Manifold**
- Ordering source area code**

Code	areas
-	Japan, Asia Australia
E	Europe
N	North America
- Thread**

-	Rc (PT)
N	NPT
T	NPTF
F	G (PF)
- P, EA, EB port size**
03 - 3/8
- Symbol**

	Port specification		Porting spec.
	P	EA, EB	A, B
1	Common 3/8	Common 3/8	Top porting 1/4, 3/8
- Stations**

02	2 stations
⋮	⋮
15	15 stations
- Base Model**

Type	Pilot exhaust	Applicable valve
31	Pilot common EXH	VFS3□20-□□-02/03
		VFS3□30-□□-02/03

Manifold construction

Manifold block assembly VVFS3000-1A-30

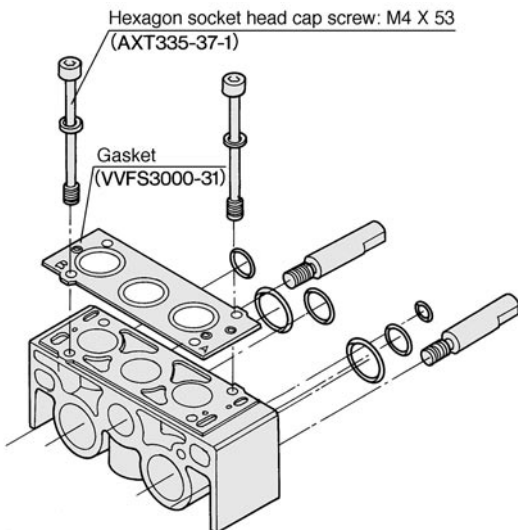

For increasing the manifold bases, please prepare the manifold block assembly No.

Note) Also VFS3□20 is possible to manifold. In this case, it uses an individual pilot exhaust.

How to Order Manifold Base Assembly

Please indicate manifold base style, valve model, and blank plate.

<<Example>>

(Manifold base)	□ VV5FS3-31-061-03-Q 1
(2 position single)	□ VFS3130-1D-02-Q 3
(2 position double)	□ VFS3230-1D-02-Q 2
(Blank plate)	VVFS3000-10A-1 1

VFS3000

31 Type Manifold Pilot Common Exhaust: VV5FS3-31- Station 1-03

Grommet: G

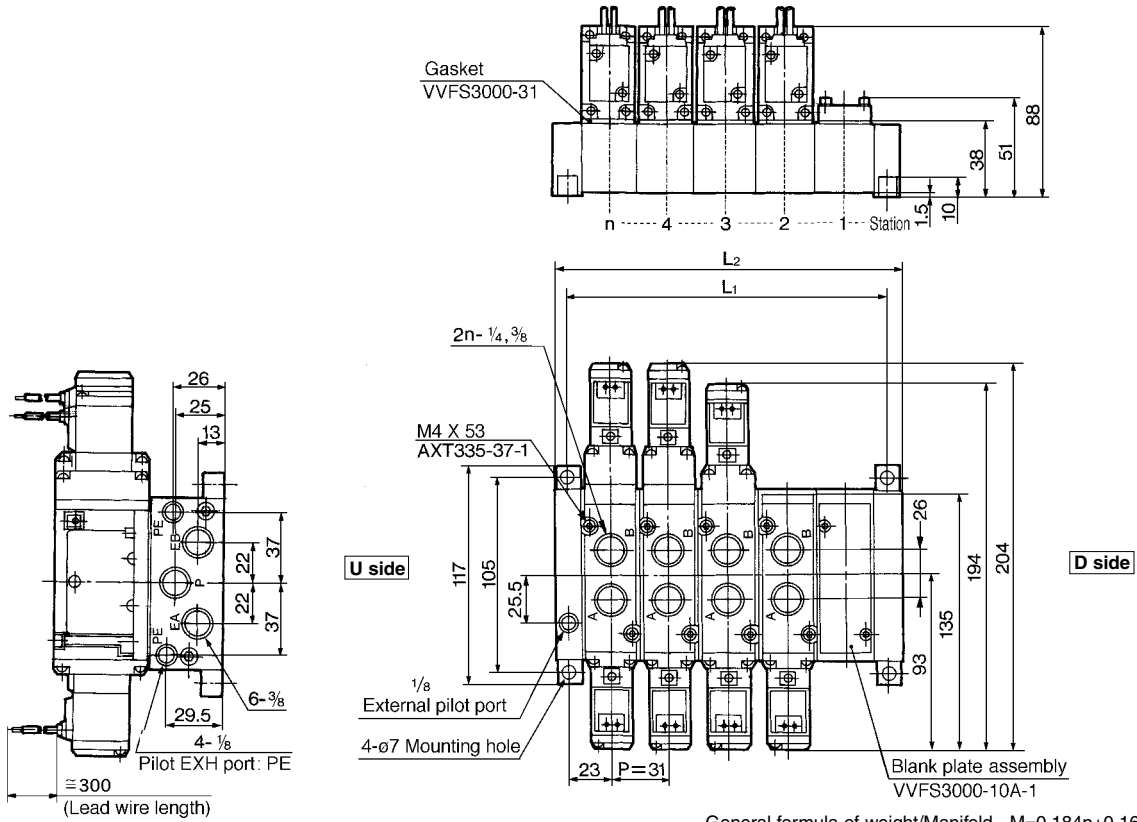

General formula of weight/Manifold $M=0.184n+0.16$ (kg) n: Station

Grommet terminal: E, EZ

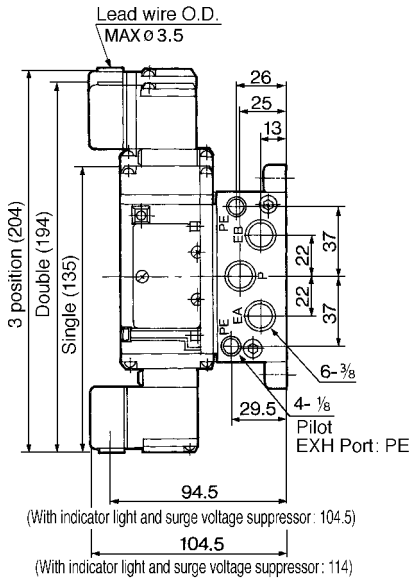

Conduit terminal: T, TZ

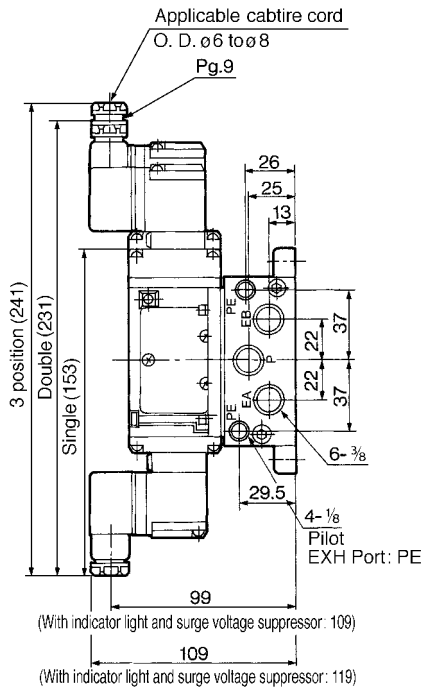

DIN connector: D, DZ

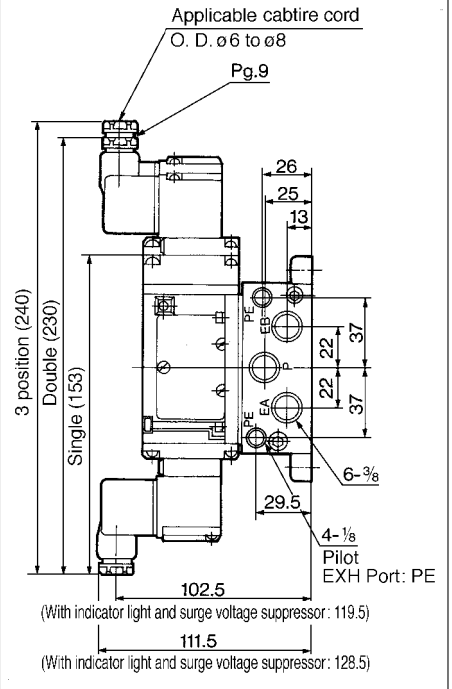

n: Station

L	n	2	3	4	5	6	7	8	9	10	Equation
L ₁		77	108	139	170	201	232	263	294	325	L ₁ =31 X n+15
L ₂		92	123	154	185	216	247	278	309	340	L ₂ =31 X n+30

5 Port Pilot/Metal Seal

Plug-in/Non Plug-in

Series VFS2000

Compact despite large flow capacity 1/4: N/min 815

Small Power Consumption/1.8W DC

Easy to maintain

2 styles of sub-plates: plug-in and non plug-in.

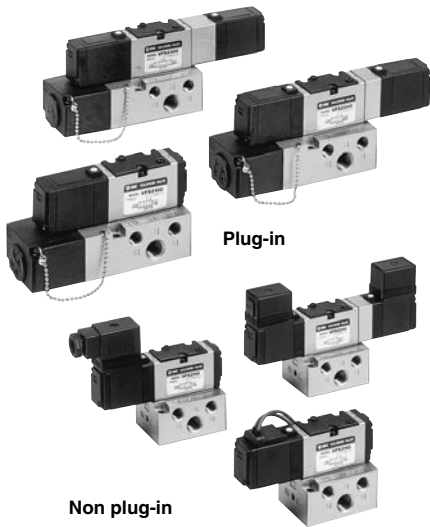

Small and Light weight sub-plate

Smaller size and lighter weight than standard.

Note) Cv factor and piping port locations for compact sub plate are different from those in the standard style.

Refer to p.1.17-52 for details.

Sub plate	Thickness (mm)	Weight (kg)	Eff. area (mm ²) (N/min)*
Standard	31.0	0.2	15 (815)
Compact	25.5	0.13	10.8 (589)

* 2 position single 1/4

JIS Symbol

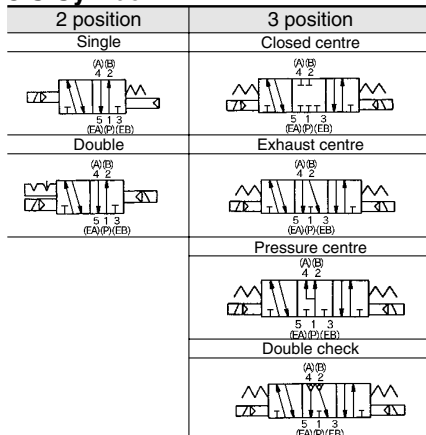

Model

Configuration	Model		Port size	Effective area (mm ²) (N/min)	Max. operating freq. (CPM) (1)	Response time (ms) (2)	Weight (kg) (3)
	Plug-in	Non plug-in					
2 position	Single	VFS2100	VFS2110	1/8	12.6(687)	1200	15 or less
				1/4	15 (815)		
	Double	VFS2200	VFS2210	1/8	12.6 (687)	1200	13 or less
				1/4	15 (815)		
3 position	Closed centre	VFS2300	VFS2310	1/8	11.7 (638)	600	20 or less
				1/4	12.1 (658)		
	Exhaust centre	VFS2400	VFS2410	1/8	11.7 (638)	600	20 or less
				1/4	12.1 (658)		
	Pressure centre	VFS2500	VFS2510	1/8	11.7 (638)	600	20 or less
				1/4	12.1 (658)		
	Double check	VFS2600	VFS2610	1/8	7.2 (393)	600	25 or less
				1/4	7.2 (393)		



Note 1) According to JIS B8375 (Once per 30 days) for the minimum operating frequency.

Note 2) According to JIS B8375-1981. (The valve at supply pressure 0.5MPa.) Note 3) In case of VFS2□00-□FZ-01.

Note 4) Factors of "Note 1" and "Note 2" are ones achieved in controlled clean air.

Standard Specifications

Valve	Fluid		Air and inert gas
	Max. operating pressure		1.0MPa
	Min. operating pressure	2 position	0.1MPa
		3 position	0.15MPa
	Proof pressure		1.5MPa
	Ambient and fluid temperature		-10 to +60°C (1)
	Lubrication		Not required (2)
	Pilot valve manual override		Non-locking push (Flush)
	Shock/vibration resistance		150/50m/s ² (3)
	Protection structure		D type: Splash proof (4)
Solenoid	Rated voltage		100V, 200V AC (50/60Hz), 24V DC
	Allowable voltage		-15 to +10% rated voltage
	Coil insulation		Class B or equivalent (130°C) (5)
	Apparent power (Power consumption) AC	Inrush	5.6VA/50Hz, 5.0VA/60Hz
		Holding	3.4VA (2.1W)/50Hz, 2.3VA (1.5W)/60Hz
	Power consumption DC		1.8W
	Electrical entry		Plug-in Non Plug-in DIN connector



Note 1) Use dry air if low temperatures.

Note 2) Use turbine oil class 1 (ISO VG32), if lubricated.

Note 3) Shock resistance: No malfunction from test using drop impact tester to axis and right angle directions of main valve and armature, each one time when energized and de-energized. (Value in the initial stage.)

Vibration resistance: No malfunction from test with 8.3 to 2000Hz, 1 sweep, to axis and right angle directions of main valve and armature, each one when energized and de-energized. (Value in the initial stage.)

Note 4) According to JIS C0920.

Note 5) According to JIS C4003.

Option Specifications

Pilot style	External pilot (1)
Manual override	Non-locking push style (Extended), Locking style (Slotted), Locking style (Lever)
Voltage	110 to 120V, 220V/240V AC 50/60Hz 12V, 100V DC
Porting	Bottom porting
Option	With indicator light and surge voltage suppressor



Note 1) Operating pressure: 0 to 1.0MPa

Pilot pressure ——— 2 position: 0.1 to 1.0MPa 3 position: 0.15 to 1.0MPa

VFS2000

How to Order



With insert plug with lead wire



With terminal block

Ordering source area code

Code	areas
-	Japan, Asia Australia
E	Europe
N	North America

Option

-	None
Z	With indicator light and surge voltage suppressor

Porting

-	Side
B*	Bottom

*Option

Body

O: Plug-in sub-plate

Electrical entry

F: Plug-in

Port size

		Without sub-plate	
01	1/8	Plug-in conduit terminal (with terminal block), Standard	Nr/min 687 (1)
02	1/4		Nr/min 815 (1)
P01 ⁽²⁾	1/8	Plug-in grommet (Insert plug with lead wire), Compact	Nr/min 589 ⁽¹⁾
P02 ⁽²⁾	1/4		

Note 1) 2 position single
Note 2) Please note Cv factor and piping port location of compact sub-plate are different from ones of standard.

Thread

-	Rc (PT)
N	NPT
T	NPTF
F	G (PF)

Plug-in VFS2 2 00 5 F 01 Q

Non plug-in VFS2 2 10 1 D 02 Q

Configuration

1	2 position single
2	2 position double
3	3 position closed centre
4	3 position exhaust centre
5	3 position pressure centre
6	3 position double check

Body

1: Non plug-in sub-plate

Pilot

-	Internal
R*	External

* Option. External pilot is possible only to the one with sub-plate.

Voltage

1	100V AC (50/60Hz)
2	200V AC (50/60Hz)
3	110V to 120V AC (50/60Hz)
4	220V AC (50/60Hz)
5	24V DC
6	12V DC
7	240V AC (50/60Hz)
9	Other, (250V or less)

Order Made Contact SMC for other voltages (9)

Protective class class I (Mark: )

Pilot valve manual override

-	Non-locking push style (Flush)	B*: Locking style (Slotted)
A*	Non-locking push style (Extended)	C*: Locking style (Lever)

* Option

Indicator light/surge voltage suppressor

-	None
Z	With indicator light and surge voltage suppressor

Electrical entry

D:	DIN connector	Y: DIN connector (DIN 43650)
DO:	Without connector	YO: Without DIN connector

How to Order Pilot Valve Assembly

SF4-1DZ-20-Q

Voltage	Electrical entry/Indicator light and surge voltage suppressor.	Manual override
1	D	-
2	DZ	A*
3	DO	B*
4	DOZ	C*
5	Y	-
6	YO	-
7		
9		

* Without DIN connector.

* Option

Maximum Cylinder Speed

Condition: Supply pressure 0.5MPa, Load factor 50%

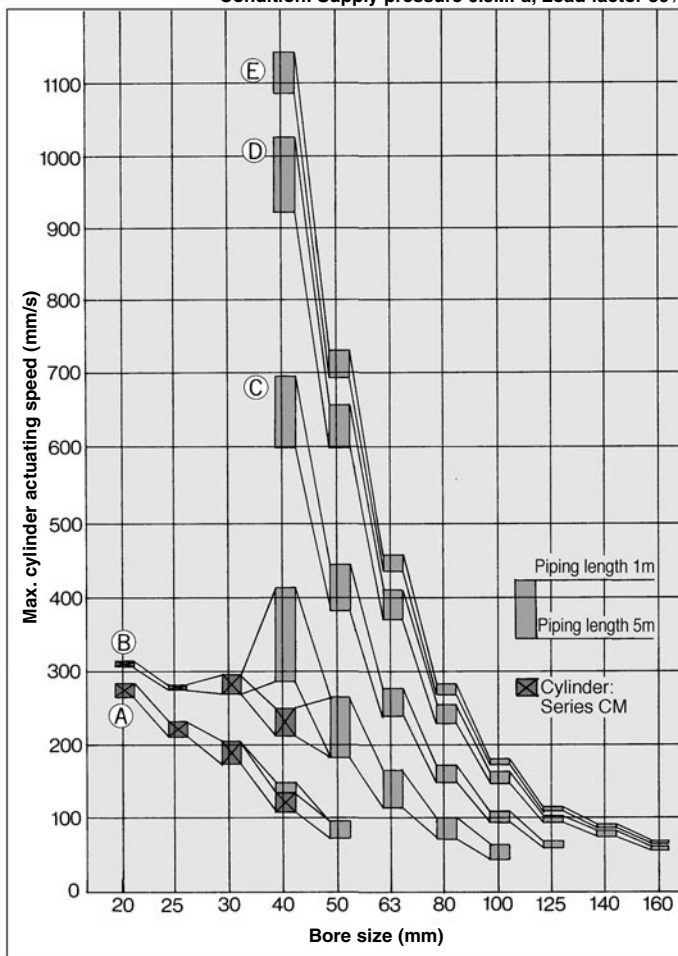

System diagram

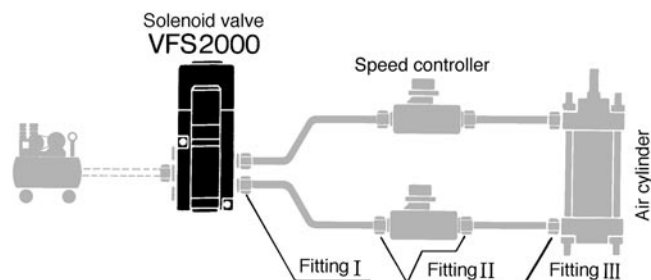

System components

System	Solenoid valve	Speed controller	Silencer	Fitting (Tube O.D. X connecting thread)		
				1	2	3
A	VFS2000-01 1/8 (S=12.6mm ²)	AS2000-01 (S=5mm ²)	AN110-01 (S=35mm ²)	ø4 X 1/8	ø4 X 1/8	ø4 X 1/8 to 1/4
B		AS3000-02 (S=12mm ²)	AN110-01 (S=35mm ²)	ø6 X 1/8	ø6 X 1/8	ø6 X 1/8 to 1/2
C		AS3000-02 (S=12mm ²)	AN110-01 (S=35mm ²)	ø8 X 1/8	ø8 X 1/8	ø8 X 1/8 to 1/2
D	VFS2000-02 1/4 (S=15mm ²)	AS4000-02 (S=24mm ²)	AN110-01 (S=35mm ²)	ø10 X 1/4	ø10 X 1/4	ø10 X 1/4 to 1/2
E		AS4000-02 (S=24mm ²)	AN110-01 (S=35mm ²)	ø12 X 1/4	ø12 X 1/4	ø12 X 1/4 to 1/2

Note) The piping with a compact sub-plate of pipe connecting bore 1/8 and 1/4 is equivalent to the system A, B, C.

Double Check Spacer Specifications

Holding cylinder mid-position for a long periods.

The concurrent use of double check spacer with built-in double check valve can stop cylinder or mid-position and hold it without being affected by air leakage spool seals.

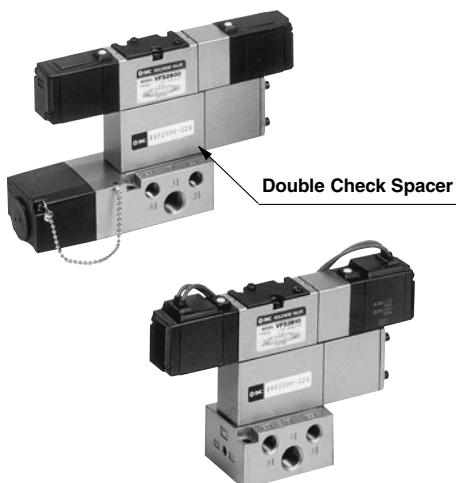

Specifications

Double check spacer	Plug-in		Non plug-in	
	VVFS2000-22A-1		VVFS2000-22A-2	
Applicable solenoid valve	VFS2400-□F		VFS2410-□ ^G _E _T _D	
Leakage* (cm ³ /min) (ANR)	Solenoid one side energized	P	EA	210 or less
			EB	210 or less
	Solenoid both sides de-energized	P	EA	210 or less
			EB	210 or less
A	EA	0		
B	EB	0		

*Supply pressure 0.5MPa

⚠️ Precaution

- In the case of 3 position double check valve (VFS26□0), check the leakage from piping and fittings in between valve and cylinder by means of synthetic detergent solutions, and ensure that there is no such leakage found there. Also check the leakage from cylinder seal and piston seal. If there is any leakage, sometimes the cylinder, when valve is de-energized, can move without stopping at mid-position.
- Be aware that if the exhaust side is restricted excessively, the intermediate stopping accuracy will decrease and will lead to improper intermediate stops.

Check Valve Operation

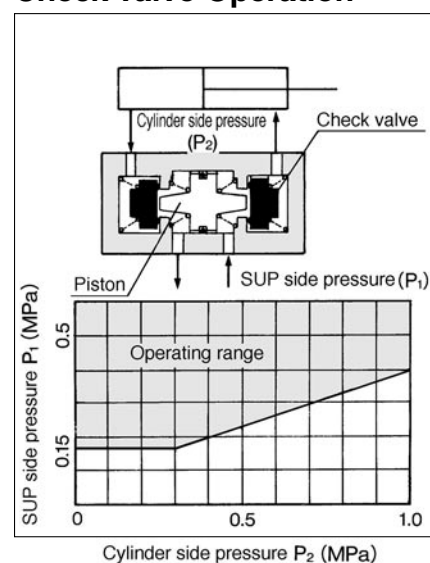

- The combination of VFS21⁰, VFS22⁰, and a double check spacer can be used as prevention of falling at the stroke end but cannot hold the intermediate position of the cylinder.

VFS2000

Construction

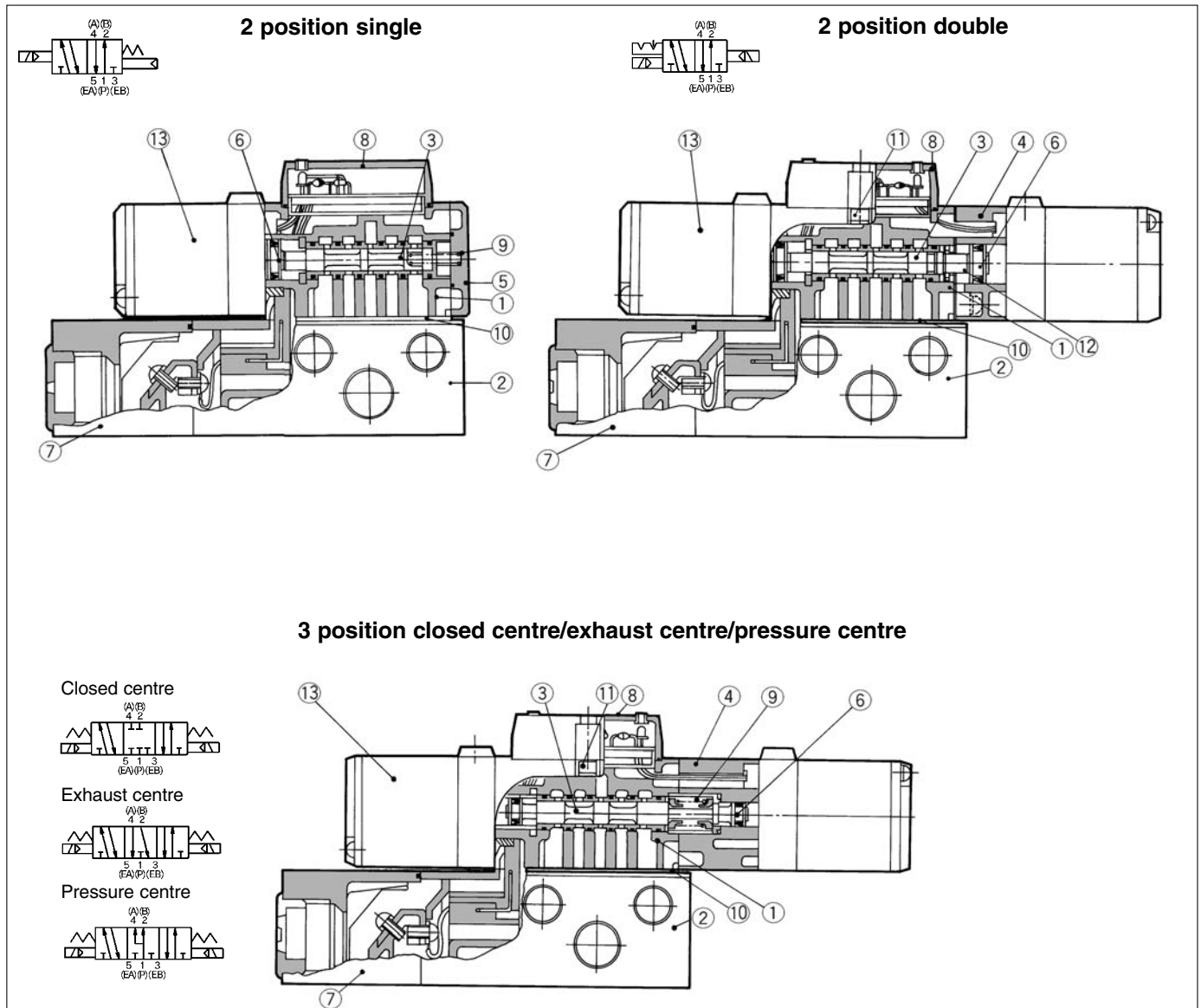

Component Parts

No.	Description	Material	Note
①	Body	Aluminium die-cast	Platinum silver
②	Sub-plate	Aluminium die-cast	Platinum silver
③	Spool/Sleeve	Stainless steel	—
④	Adaptor plate	Aluminium die-cast	Platinum silver
⑤	End plate	Resin	Black
⑥	Piston	Resin	—
⑦	Junction cover	Resin	—
⑧	Light cover	Resin	—

Subplate Assembly (Standard)

Plug-in	VFS2000-LP- ⁰¹ / ₀₂
Non plug-in	VFS2000-LS- ⁰¹ / ₀₂



* Without mounting screw and gasket .



* Refer to p.1.17-52 for compact style.

Replacement Parts

No.	Description	Material	Part No.		
			VFS21□□	VFS22□□	VFS23□□, 24□□, 25
⑨	Return spring	Stainless steel	NVF2000-48	—	AXT624-19-1
⑩	Gasket	NBR	AXT624-20-2	AXT624-20-2	AXT624-20-2
⑪	Hexagonal socket head cap screw	Steel	AXT624-26	AXT624-26	AXT624-26
⑫	Detent assembly	—	—	AXT624-11A	—
⑬	Pilot valve assembly	—	Refer to "How to order/Pilot valve assembly" on p.1.17-34.		

Plug-in 2 Position Single/Double, 3 Position Closed Centre/Exhaust Centre/Pressure Centre/Double Check

2 position single: VFS2100-□F-01

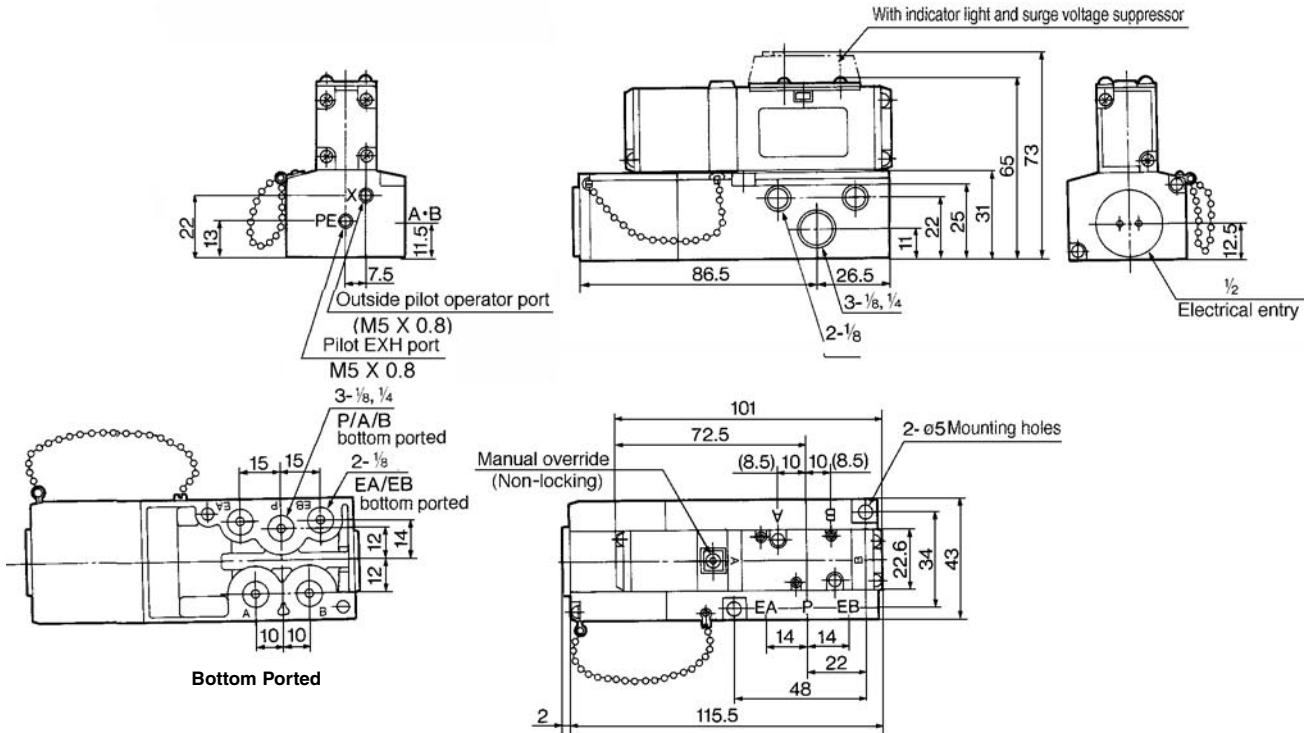

2 position double: VFS2200-□F-01

3 position closed centre: VFS2300-□F-01

3 position exhaust centre: VFS2400-□F-01

3 position pressure centre: VFS2500-□F-01

3 position double check: VFS2600-□F-01

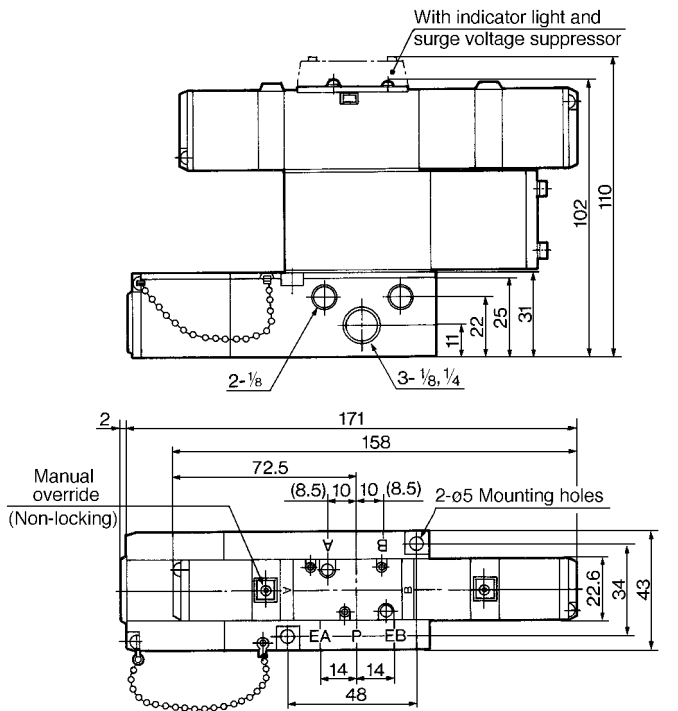
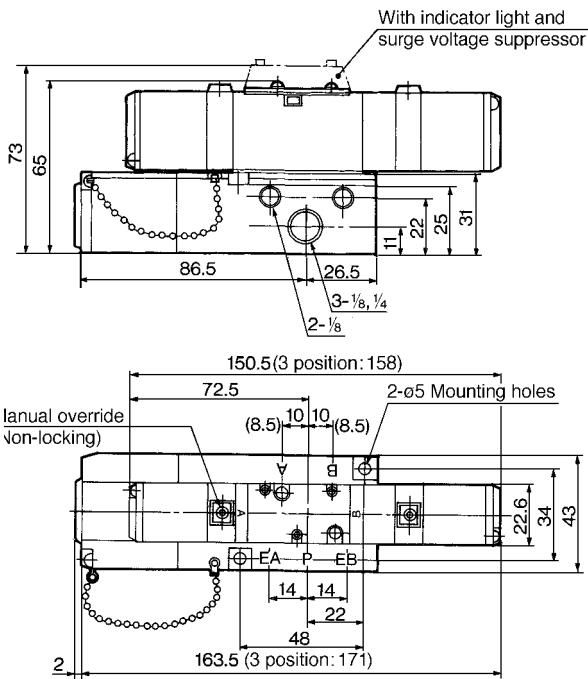

VFS2000

Non Plug-in 2 Position Single

Grommet: VFS2110-□G-⁰¹/₀₂

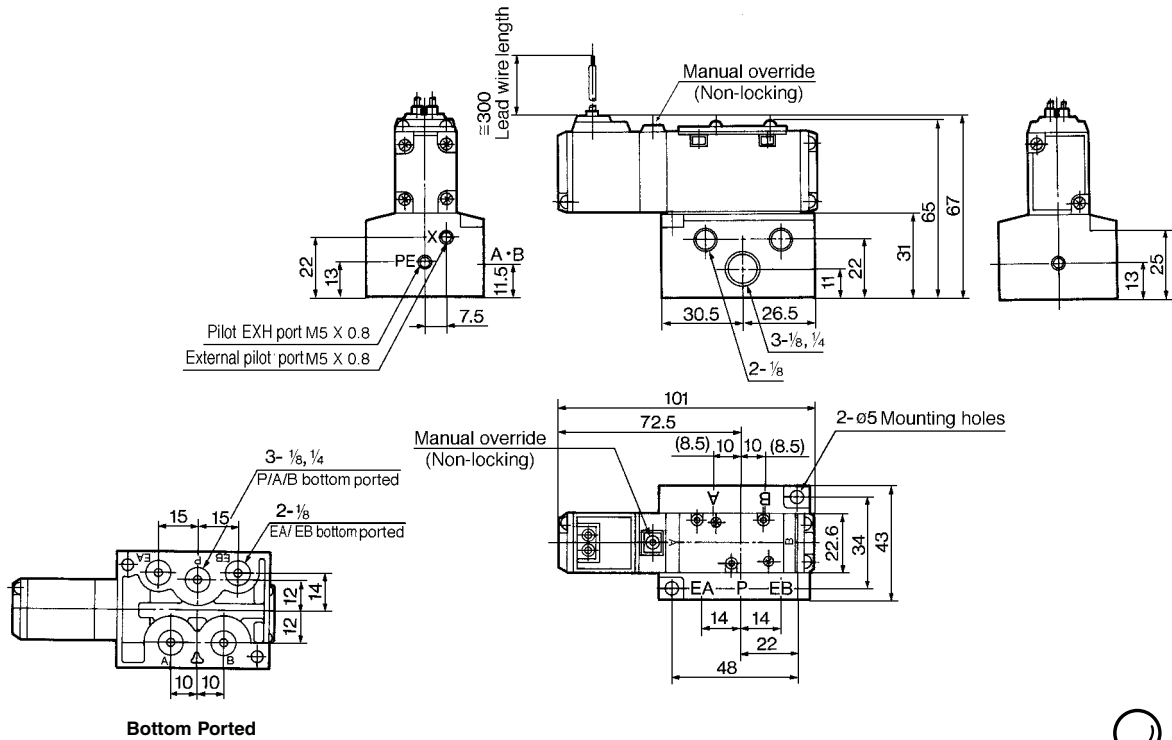

Grommet terminal: VFS2110-□E-⁰¹/₀₂

Lead wire O.D. MAX ø3.5 With indicator light and surge voltage suppressor

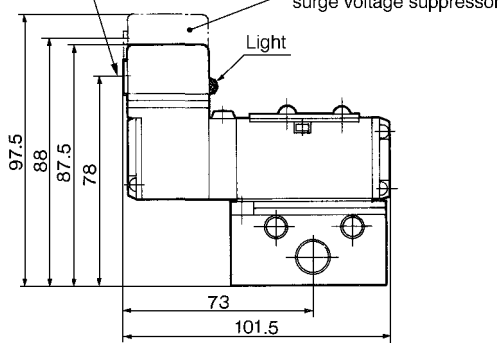

DIN connector: VFS2110-□D-⁰¹/₀₂

Applicable cabtire cord Pg.9 With indicator light and surge voltage suppressor

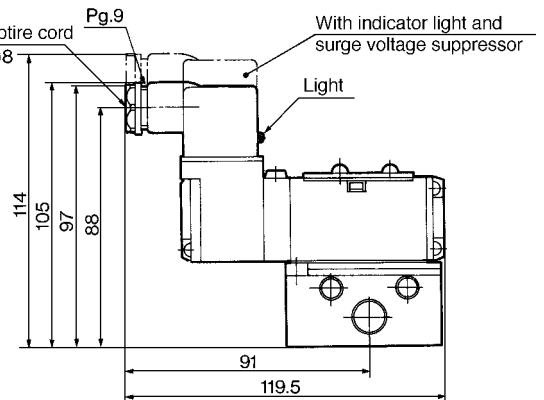

Conduit terminal: VFS2110-□T-⁰¹/₀₂

Applicable cabtire cord O.D. ø6 to ø8 Pg.9 With indicator light and surge voltage suppressor

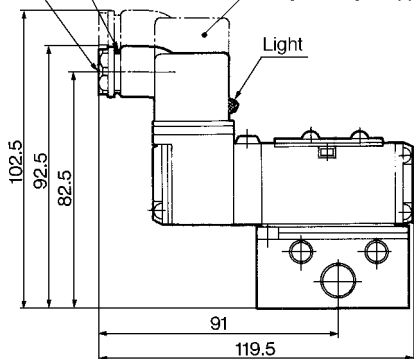

Non Plug-in 2 Position Double, 3 Position Closed Centre/Exhaust Centre/Pressure centre

Grommet: 2 position double VFS2210-□G-⁰¹/₀₂ 3 position closed centre VFS2310-□G-⁰¹/₀₂
 3 position exhaust centre VFS2410-□G-⁰¹/₀₂ 3 position pressure centre VFS2510-□G-⁰¹/₀₂

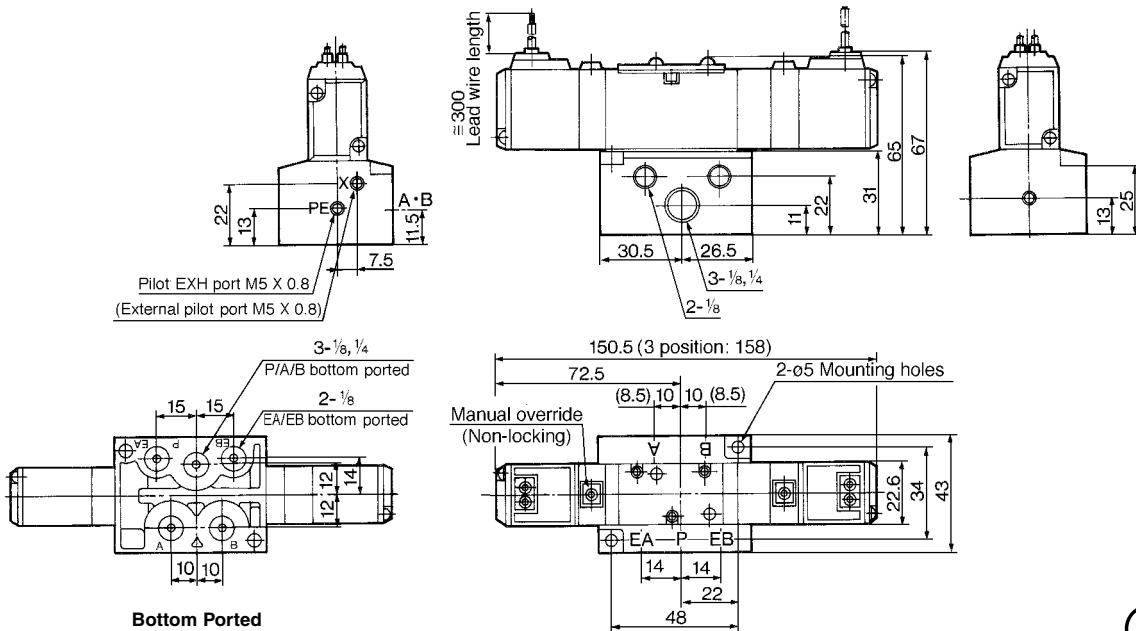

Grommet terminal: Double VFS2210-□E-⁰¹/₀₂
 Closed centre VFS2310-□E-⁰¹/₀₂
 Exhaust centre VFS2410-□E-⁰¹/₀₂
 Pressure centre VFS2510-□E-⁰¹/₀₂

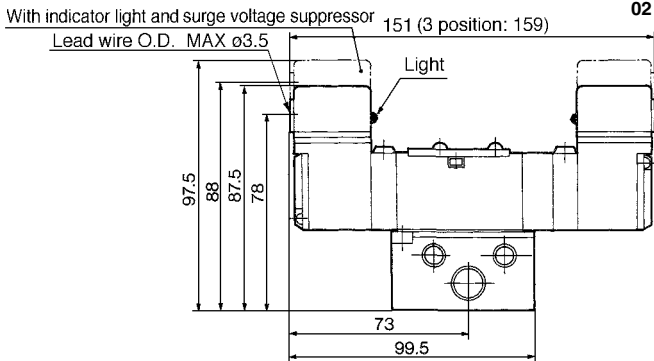

DIN connector: Double VFS2210-□D-⁰¹/₀₂
 Closed centre VFS2310-□D-⁰¹/₀₂
 Exhaust centre VFS2410-□D-⁰¹/₀₂
 Pressure centre VFS2510-□D-⁰¹/₀₂

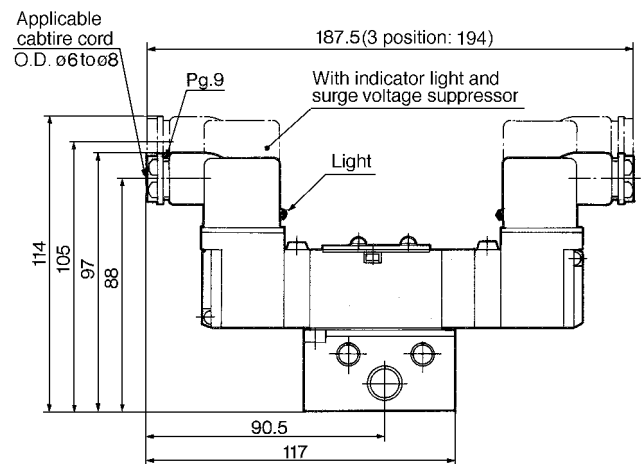

Conduit terminal: Double VFS2210-□T-⁰¹/₀₂
 Closed centre VFS2310-□T-⁰¹/₀₂
 Exhaust centre VFS2410-□T-⁰¹/₀₂
 Pressure centre VFS2510-□T-⁰¹/₀₂

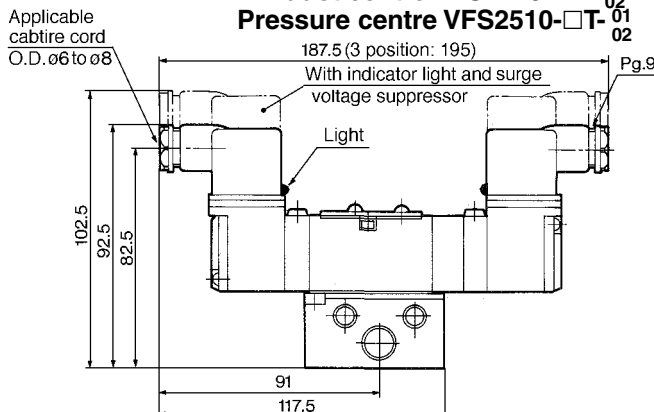

VFS2000

Non Plug-in 3 Position Double Check

Grommet: VFS2610-□G-⁰¹/₀₂

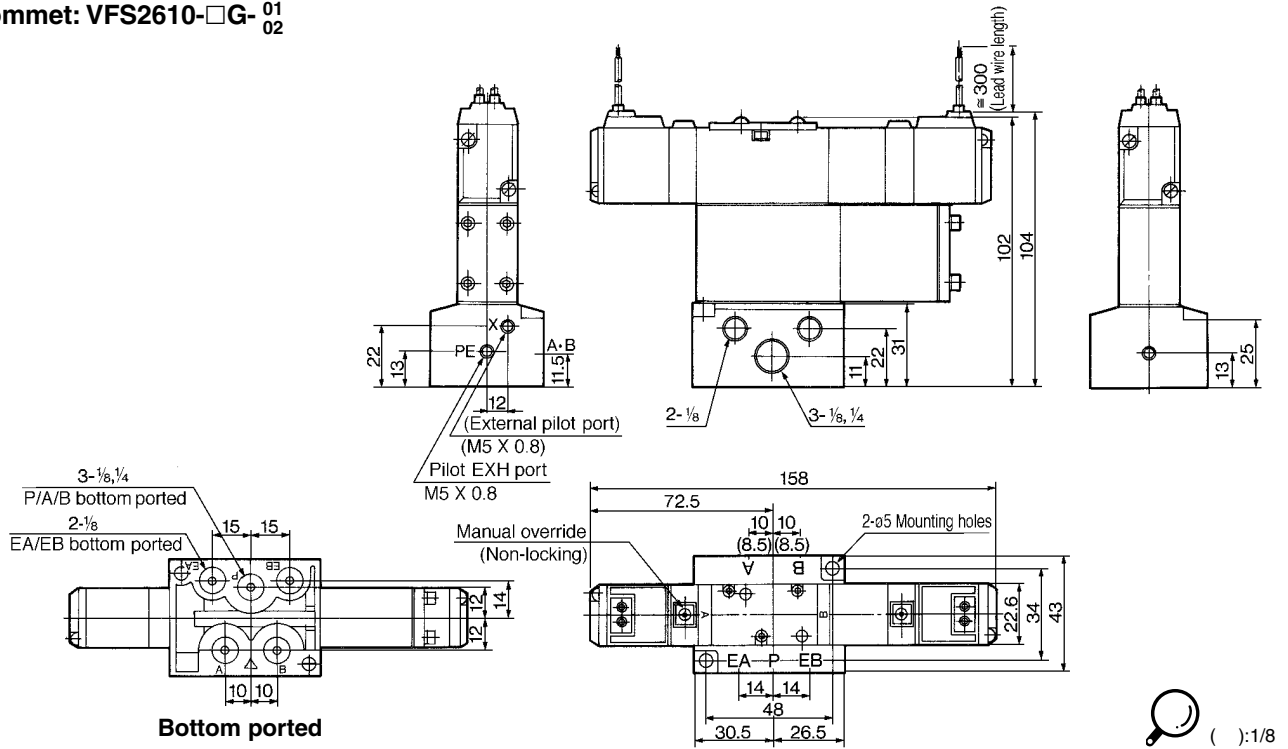

Bottom ported

Grommet terminal: VFS2610-□E-⁰¹/₀₂

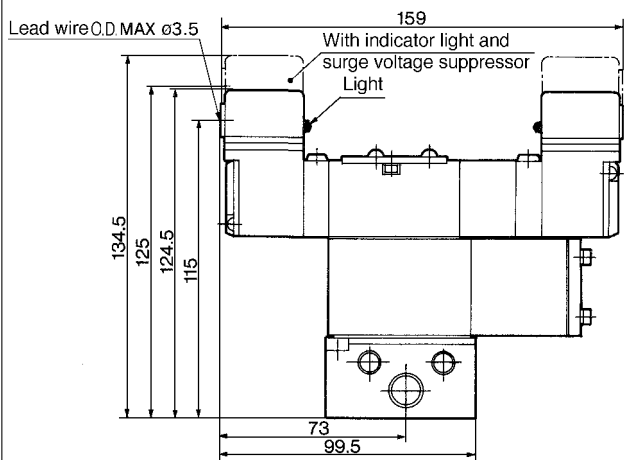

DIN connector: VFS2610-□D-⁰¹/₀₂

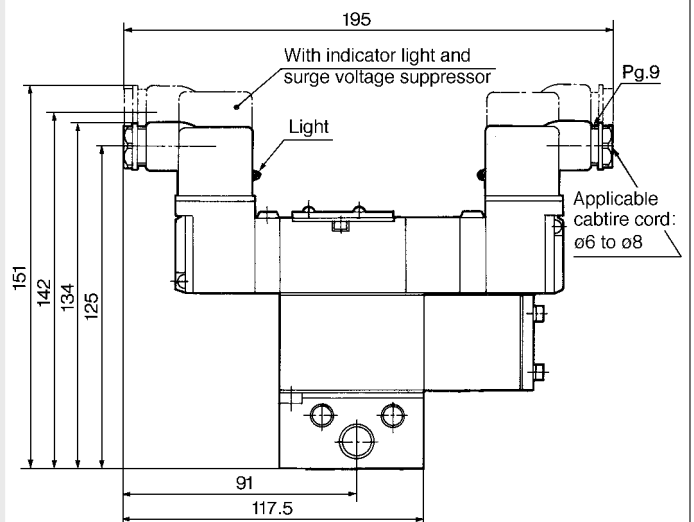

Conduit Terminal: VFS2610-□T-⁰¹/₀₂

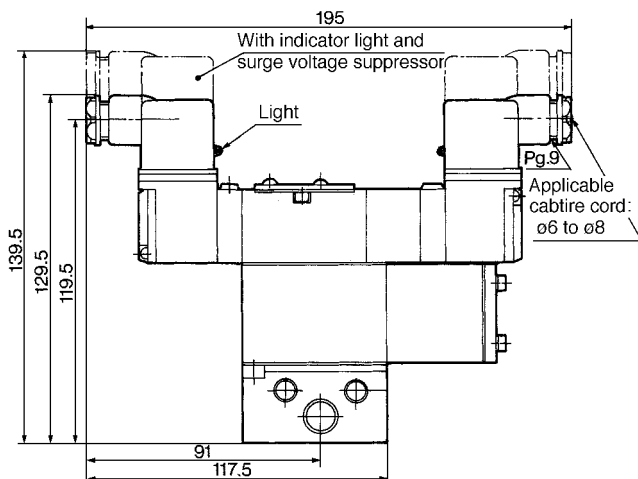

Plug-in: Insert Plug with Lead Wire

The insert plug is attached to the manifold block and lead wire is plugged into the valve side. Please connect with corresponding power side.

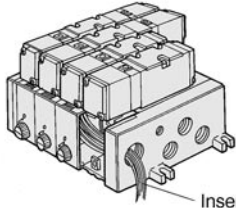

Insert plug lead wire

VV5FS2 - 01 - 06 1 - 01 - Q

Series VFS2000 Manifold Plug-in

Insert plug with lead wire

Ordering source area code

Code	areas
-	Japan, Asia Australia
E	Europe
N	North America

Stations

02	2 stations
15	15 stations

Symbol

Symbol	Port specifications	Porting
P	EA, EB	A, B
1		Side
2*	Com.	Com.
3*	Com.	Indi.
4*	Com.	Indi.
5*	Indi.	Com.
6*	Indi.	Com.
7*	Indi.	Indi.
8*	Indi.	Indi.

*Option

Thread

-	Rc (PT)
N	NPT
T	NPTF
F	G (PF)

Port size

Symbol	P, EA, EB	A, B
01		1/8
02	1/4	1/4
M		Mix

*Bottom porting: 1/8 only.

Plug-in: With Terminal Block

Since lead wires of solenoid valve are connected with the terminals on upper surface of terminal block, corresponding lead wires from power source can be wired at the bottom of terminal block.

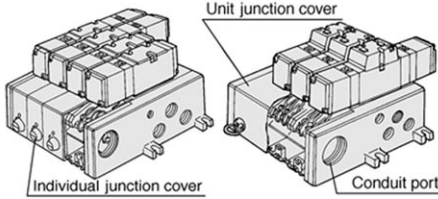

Unit junction cover

Individual junction cover

Conduit port

VV5FS2 - 01T 1 - 08 1 - 02 - Q

Series VFS2000 Manifold Plug-in with terminal block

Plug-in with terminal block

Junction cover

Code	areas
-	Japan, Asia Australia
E	Europe
N	North America

Stations

02	2 stations
15	15 stations

Symbol

Symbol	Port specifications	Porting
P	EA, EB	A, B
1		Side
2*	Com.	Com.
3*	Com.	Indi.
4*	Com.	Indi.
5*	Indi.	Com.
6*	Indi.	Com.
7*	Indi.	Indi.
8*	Indi.	Indi.

*Option

Thread

-	Rc (PT)
N	NPT
T	NPTF
F	G (PF)

Port size

Symbol	P, EA, EB	A, B
01		1/8
02	1/4	1/4
M		Mix

*Bottom porting: 1/8 only.

Plug-in: With Multi-connector

(Wiring specifications: Please refer to p.1.17-8)

- Master connection of power and solenoid valves.
- Quick wiring permits ease of installation.

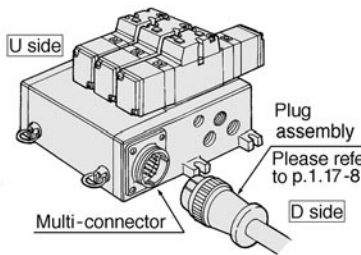

U side

Plug assembly
Please refer to p.1.17-8

Multi-connector

D side

VV5FS2 - 01C D 1 - 05 2 - 01 - Q

Series VFS2000 Manifold Plug-in With multi-connector

Plug-in With multi-connector

Mounting direction of connector

D	D side mounting
U	U side mounting

Junction cover

Code	areas
-	Japan, Asia Australia
E	Europe
N	North America

Stations

02	2 stations
08	8 stations

*Max: 8 stations.

Symbol

Symbol	Port specifications	Porting
P	EA, EB	A, B
1		Side
2*	Com.	Com.
3*	Com.	Indi.
4*	Com.	Indi.
5*	Indi.	Com.
6*	Indi.	Com.
7*	Indi.	Indi.
8*	Indi.	Indi.

*Option

Thread

-	Rc (PT)
N	NPT
T	NPTF
F	G (PF)

Port size

Symbol	P, EA, EB	A, B
01		1/8
02	1/4	1/4
M		Mix

*Bottom porting: 1/8 only.

Plug-in: With D-sub Connector

(Wiring specifications: Please refer to p.1.17-8)

- Wide range of interchangeability (MIL Spec DIN connector terminal-25 pcs attached.)
- Quick wiring permits easier installation.

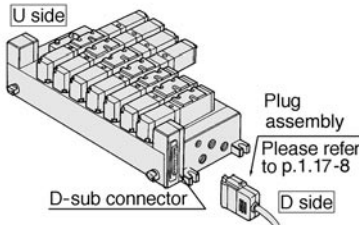

U side

Plug assembly
Please refer to p.1.17-8

D-sub connector

D side

VV5FS2 - 01F U 1 - 06 1 - 01 - Q

Series VFS2000 Manifold Plug-in with D-sub connector

Plug-in with D-sub connector

Mounting direction of connector

D	D side mounting
U	U side mounting

Junction cover

Code	areas
-	Japan, Asia Australia
E	Europe
N	North America

Stations

02	2 stations
08	8 stations

*Max: 8 stations.

Symbol

Symbol	Port specifications	Porting
P	EA, EB	A, B
1		Side
2*	Com.	Com.
3*	Com.	Indi.
4*	Com.	Indi.
5*	Indi.	Com.
6*	Indi.	Com.
7*	Indi.	Indi.
8*	Indi.	Indi.

*Option

Thread

-	Rc (PT)
N	NPT
T	NPTF
F	G (PF)

Port size

Symbol	P, EA, EB	A, B
01		1/8
02	1/4	1/4
M		Mix

*Bottom porting: 1/8 only.

Non Plug-in: DIN Connector

- Wiring for every valve

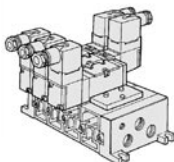

VV5FS2 - 10 - 05 2 - 01 - Q

Series VFS2000 Manifold Non plug-in

Ordering source area code

Code	areas
-	Japan, Asia Australia
E	Europe
N	North America

Stations

02	2 stations
15	8 stations

*Option

Symbol

Symbol	Port specifications	Porting
P	EA, EB	A, B
1		Side
2*	Com.	Com.
3*	Com.	Indi.
4*	Com.	Indi.
5*	Indi.	Com.
6*	Indi.	Com.
7*	Indi.	Indi.
8*	Indi.	Indi.

*Option

Thread

-	Rc (PT)
N	NPT
T	NPTF
F	G (PF)

Port size

Symbol	P, EA, EB	A, B
01		1/8
02	1/4	1/4
M		Mix

*Bottom porting: 1/8 only.

Note) The individual specification of the P port at the composition symbol 3 to 8 or the EA, EB, ports should be taken as individual port using a block plate. Therefore, if an individual port is using a single SUP spacer of option or a single EXH spacer, the composition symbol mark is "1".

VFS2000

Manifold Specifications

Base Style	Wiring	Porting	Port size		No. of Stations	Applicable solenoid valve
		A, B port	P, EA, EB	A, B		
Plug-in VV5FS2-01□	<ul style="list-style-type: none"> •Insert plug with lead wire •With terminal block •With multi connector •With D-sub connector 	Side Bottom	1/4	1/8, 1/4	2 to 15	VFS2□00-□F
Non plug-in VV5FS2-10	<ul style="list-style-type: none"> •Grommet •Grommet terminal •Conduit terminal •DIN connector 					VFS2□10-□G

*With multi connector, or with D-sub connector: 8 stations max.

Manifold Stations and Effective Area (mm²) (Cv factor)

Porting/No. of stations	First station	Fifth station	Tenth station	Fifteenth station
P→A or B	12.4 (677)	12.4 (677)	12.3 (667)	12.2 (667)
A→EA, B→EB	14.6 (795)	14.6 (795)	14.6 (795)	14.5 (795)

*2 position single. Port size: 1/4

How to Order Manifold

Please indicate manifold base style, corresponding valve, and option parts.

<<Example>>

- Plug-in with terminal block - 6 stations
(Manifold base)
VV5FS2-01T1-061-02 1
(2 position single) VFS2100-5FZ 3
(2 position double) VFS2200-5FZ 2
(Blank plate) VVFS2000-10A 1
- Non plug-in - 6 stations
(Manifold base mounted style)
VV5FS2-10-061-01 1
(2 position single) VFS2100-5 5
(3 position exhaust center) VFS2410-5D 1
(Individual EXH spacer) VVFS2000-R-01-2 1

Manifold/Option Parts Assembly

Individual SUP spacer

An individual SUP spacer set on manifold block can form SUP port for every valve.

Body	Plug-in	Non plug-in
Part No. 1/8	VVFS2000-P-01-1	VVFS2000-P-01-2
1/4	VVFS2000-P-02-1	VVFS2000-P-02-2

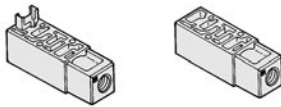

Individual EXH spacer

An individual EXH spacer set on manifold block can form EXH port for every valve.

Body	Plug-in	Non plug-in
Part No. 1/8	VVFS2000-R-01-1	VVFS2000-R-01-2
1/4	VVFS2000-R-02-1	VVFS2000-R-02-2

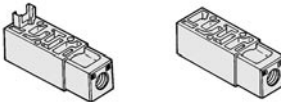

SUP block disk

When supplying manifold with more than two different pressures, high and low, insert a block plate in between stations subjected to different pressures.

Body	Plug-in	Non plug-in
Part No.	AXT625-12A	

EXH block disk

When valve exhaust affects the other stations on the circuit or when the reverse pressure valve is used to standard manifold valve, insert EXH block plate in between stations to separate valve exhaust.

Body	Plug-in	Non plug-in
Part No.	AXT625-12A	



Interface speed control

Needle valve set on the manifold block can control cylinder speed by throttling exhaust.

Body	Plug-in	Non plug-in
Part No.	VVFS2000-20A-1	VVFS2000-20A-2

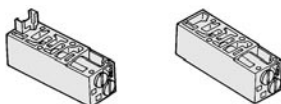

Interface regulator

Interface regulator set on manifold block can regulate the pressure to each valve.

Body	Plug-in	Non plug-in
P port regulation	ARBF2000-00-P-1	ARBF2000-00-P-2

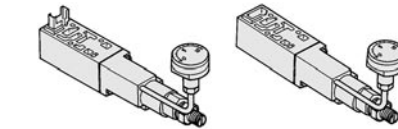

Air shutoff valve spacer

When stopping supply air and releasing residual pressure after completion of work, actuators may move from original position. Air shutoff valve spacer makes it possible to stop actuators in original position for extended periods.

Body	Plug-in	Non plug-in
Part No.	VVFS2000-21A-1	VVFS2000-21A-2



*Incompatible to subplate standard.

Air release valve spacer

The concurrent use of air release valve spacer with VFS21□0 can release air.

Body	Plug-in	Non plug-in
Part No.	VVFS2000-24A-1 _L	VVFS2000-24A-2 _R

Note) L: U side mount R: D side mount

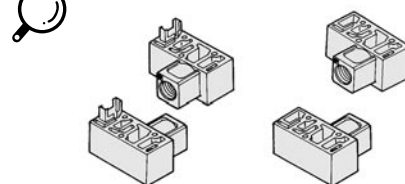

Double check spacer

The concurrent use of double check spacer with built-in double check valve can stop the cylinder at mid-position and hold for a long time without being affected by the air leakage across spool seals.

Body	Plug-in	Non plug-in
Part No.	VVFS2000-22A-1	VVFS2000-22A-2

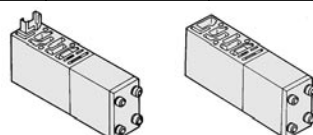

Blank plate

When disassembling valve for maintenance purposes or when spare manifold stations are required, install a blank plate on the manifold block.

Body	Plug-in	Non plug-in
Part No.	VVFS2000-10A	

Accessory

One pair of gasket and mounting thread is attached to every option parts assembly.

Manifold Options

With control unit

Plug-in/Non plug-in

- Filter, regulation valve, pressure switch and air release valve are all combined to form one unit.
- Piping work eliminated.

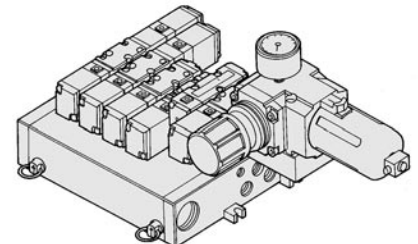

For more information, please refer to p.1.17-47.

With serial interface unit

Plug-in

- Solenoid valve wiring process reduced considerably.
- Disperse installation possible.
Manifold solenoid valve: 8 stations max, 32 positions (512 solenoids).
- Maintenance and inspection are easy.

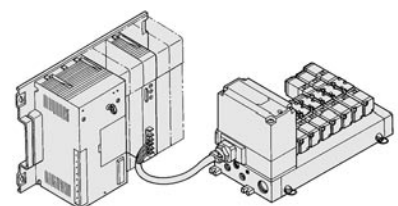

Manifold Plug-in/Non Plug-in

Plug-in (Insert plug with lead wire): VV5FS2-01- Station 1- Port size

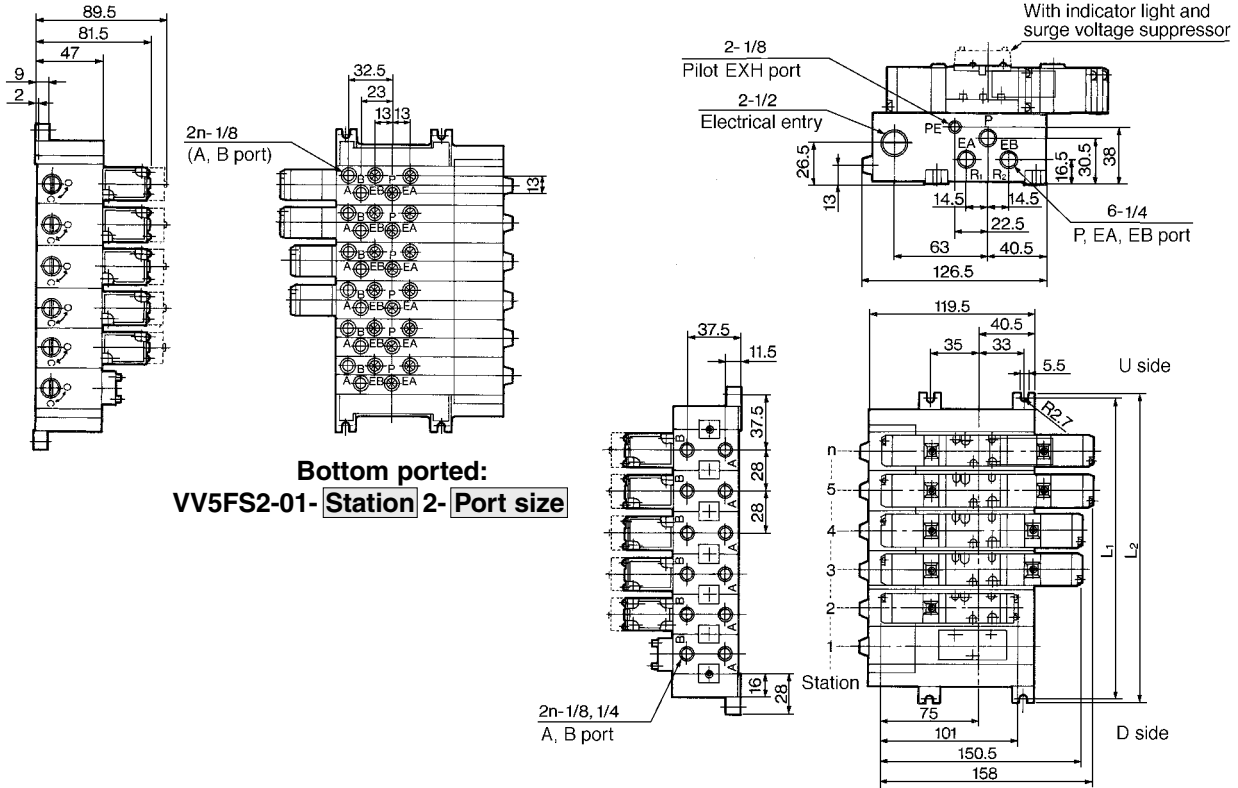

General formula of Weight/Manifold $M=0.201n+0.299$ (kg) n: Station

Non plug-in: VV5FS2-10- Station 1- Port size

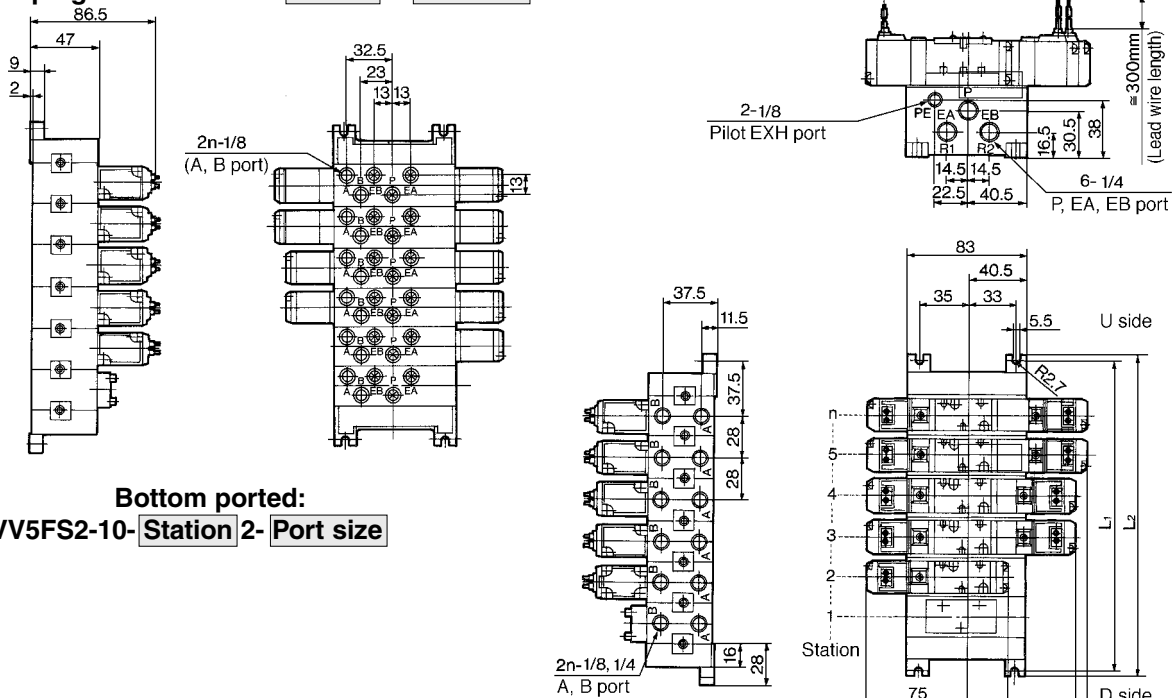

General formula of Weight/Manifold $M=0.174n+0.218$ (kg) n: Station

L	n	1	2	3	4	5	6	7	8	9	10	Equation
L1		75	103	131	159	187	215	243	271	299	327	$L1=28 \times n+47$
L2		84	112	140	168	196	224	252	280	308	336	$L2=28 \times n+56$

Manifold Plug-in with Multi-connector/With D-Sub Connector

Plug-in with multi-connector: VV5FS2-01CD1- Station 1- Port size , VV5FS2-01CU1- Station 1- Port size

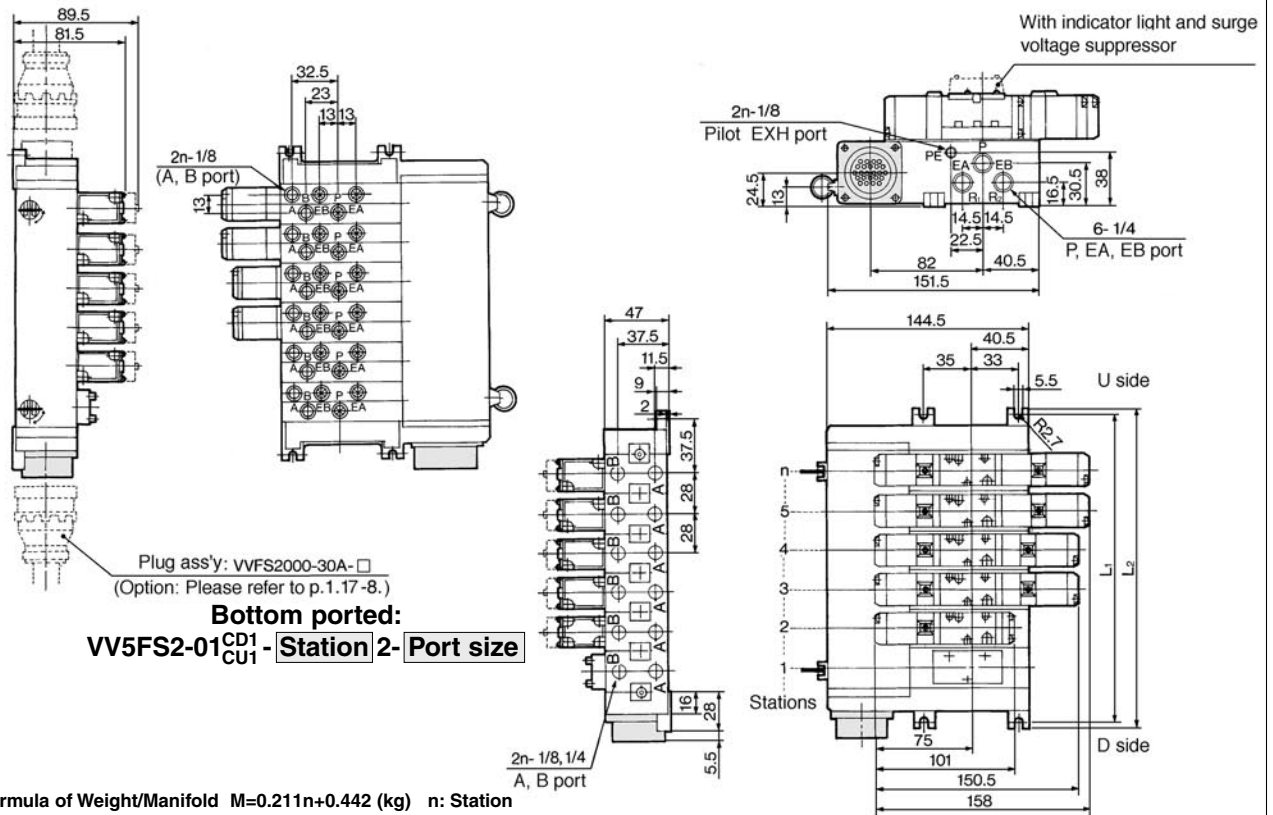

General formula of Weight/Manifold $M=0.211n+0.442$ (kg) n: Station

* Wiring specification: Please refer to p.1.17-8.

Plug-in with D-sub connector: VV5FS2-01FD1- Station 1- Port size , VV5FS2-01FU1- Station 1- Port size

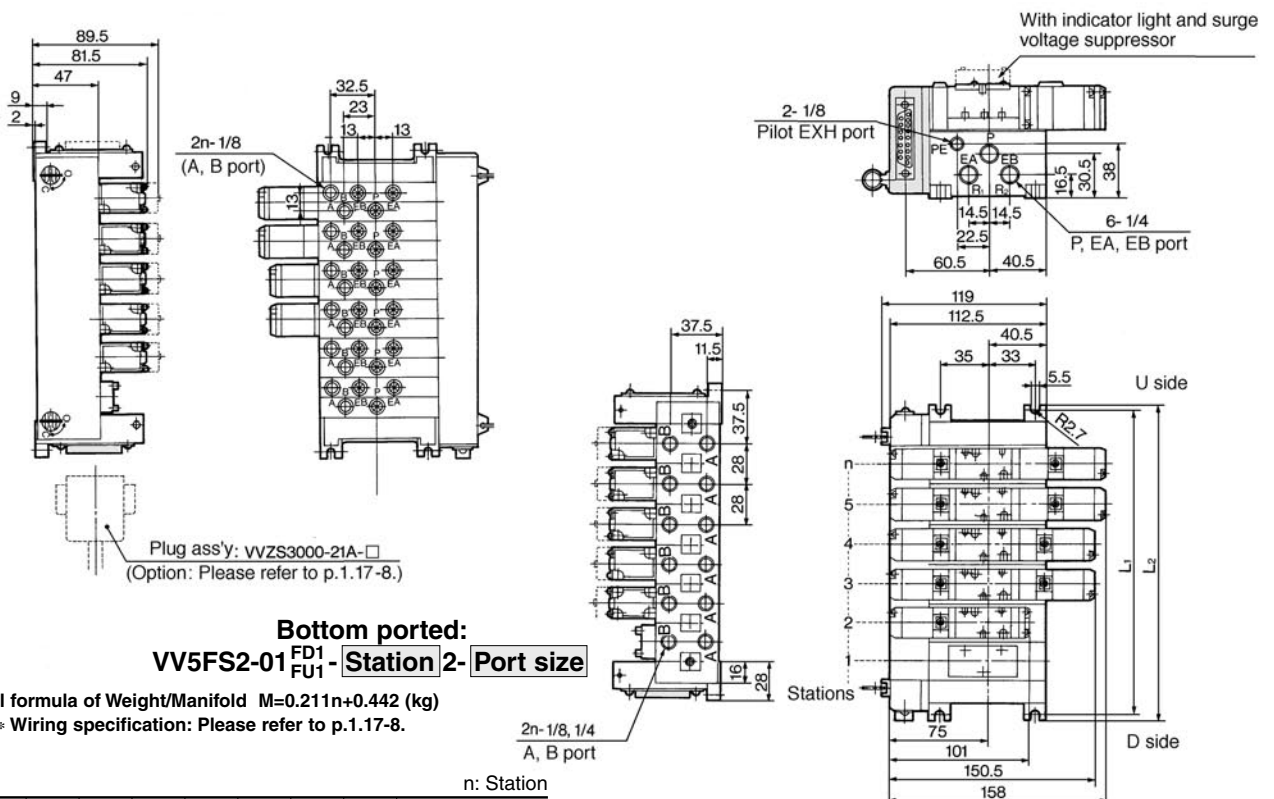

General formula of Weight/Manifold $M=0.211n+0.442$ (kg)

* Wiring specification: Please refer to p.1.17-8.



n: Station

L \ n	1	2	3	4	5	6	7	8	Equation
L1	75	103	131	159	187	215	243	271	$L1=28 \times n+47$
L2	84	112	140	168	196	224	252	280	$L2=28 \times n+56$

VFS2000

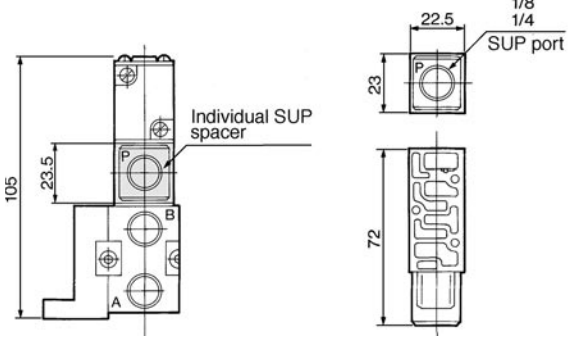
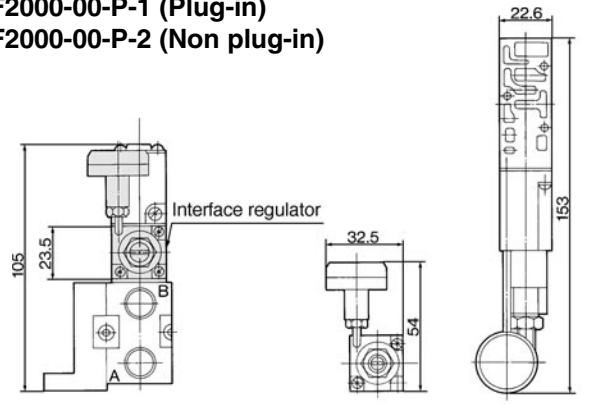
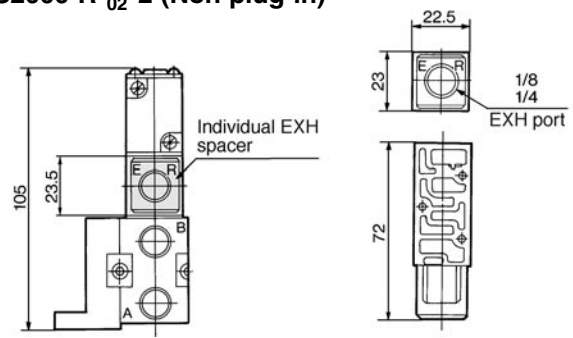
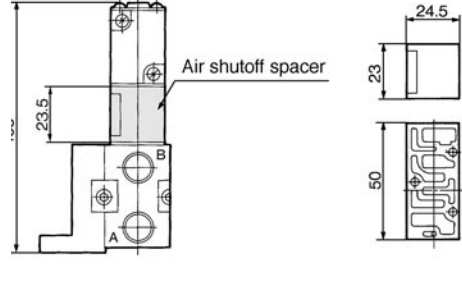
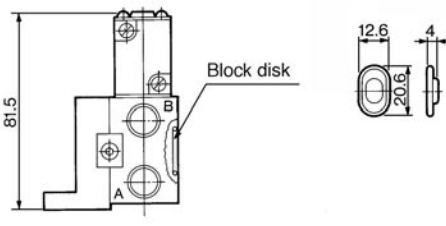
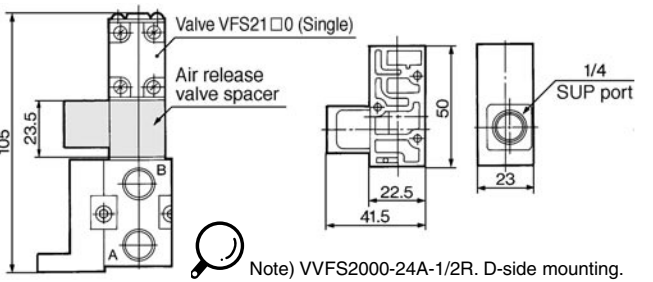
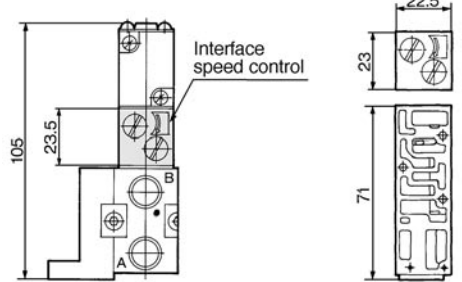
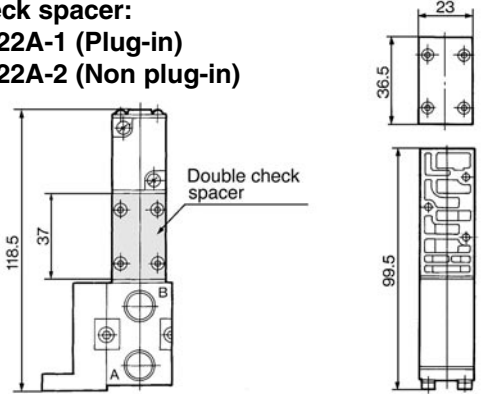
Manifold/Option Parts	Plug-in/Non Plug-in
<p>Individual SUP spacer: VVFS2000-P-01-02-1 (Plug-in) VVFS2000-P-01-02-2 (Non plug-in)</p> 	<p>Interface regulator: ARBF2000-00-P-1 (Plug-in) ARBF2000-00-P-2 (Non plug-in)</p> 
<p>Individual EXH spacer: VVFS2000-R-01-02-1 (Plug-in) VVFS2000-R-01-02-2 (Non plug-in)</p> 	<p>Air shutoff valve spacer: VVFS2000-21A-1 (Plug-in) VVFS2000-21A-2 (Non plug-in)</p> 
<p>SUP/EXH block disk: AXT625-12A</p> 	<p>Air release valve spacer: VVFS2000-24A-1^R_L (Plug-in) VVFS2000-24A-2^R_L (Non plug-in)</p>  <p>Note) VVFS2000-24A-1/2R. D-side mounting.</p>
<p>Interface speed control: VVFS2000-20A-1 (Plug-in) VVFS2000-20A-2 (Non plug-in)</p> 	<p>Double check spacer: VVFS2000-22A-1 (Plug-in) VVFS2000-22A-2 (Non plug-in)</p> 

Manifold with Control Unit

Control units (Filter, Regulator, Pressure switch, Air release valve) are all standardized to the one unit, and can be mounted on the manifold base without any attachments.

Piping processes are eliminated

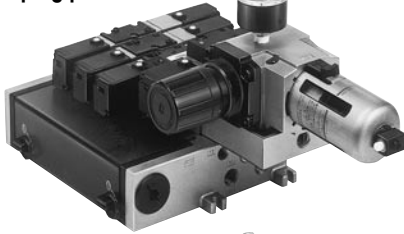

Plug-in

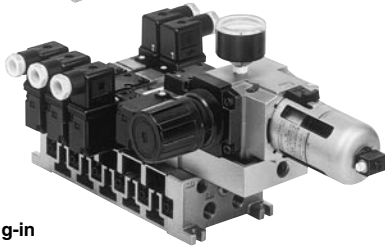

Non plug-in

Precautions

When using an air filter with auto drain or manual drain, mount the filter vertically.

Manifold specifications

Manifold style	Plug-in: VV5FS2-01□	Non plug-in: VV5FS2-10
Wiring	Insert plug with lead wire With terminal block With multi-connector With D-sub connector	Grommet Grommet terminal Conduit terminal DIN connector
Applicable valve	VFS2□00-□F	VFS2□10-□G, VFS2□10-□E VFS2□10-□T, VFS2□10-□D
Porting specifications	Common SUP, Common EXH	
	A, B port	Side: 1/8, 1/4 Bottom: 1/8 (Option)
	P, EA, EB port	Side: 1/4 Bottom: 1/8 (Option)
No. of stations	2 to 15*	

*With multi-connector, or D-sub connector: 8 stations max.

Control Unit/Specifications

Air filter (with auto drain/with manual drain)	
Filtration	5μm
Regulator	
Set Press (Secondary)	0.05 to 0.85MPa
Pressure switch (1)	
Set press. range: OFF	0.1 to 0.6MPa
Differential	0.08MPa or less
Contact	1a
Light	LED (Red)
Max. switch capacity	2V AC, 2W DC
Max. operating current	24V AC, DC. or less: 50mA
Air release valve (Single only)	
Operating press. range	0.1 to 1.0MPa

Control unit/Options

Air release valve adaptor plate (2)	<Plug-in> VVFS2000-24A-1R (D side mounting) VVFS2000-24A-1L (U side mounting)	
	<Non plug-in> VVFS2000-24A-2R (D side mounting) VVFS2000-24A-2L (U side mounting)	
Pressure switch (3)	IS1000P-2-1	
Blank plate	With control unit/Filter regulator	MP2-2
	Pressure switch	MP3-2
	Air release valve	AXT625-18A
Filter element	111511-5B	

Note 1) Voltage: 24V DC to 100V AC
Inner voltage drop: 4V

Note 2) Refer to manifold option parts on p.1.17-42.

Note 3) Non plug-in style cannot be mounted afterwards.

How to Order



Note) The manifold with plug-in attachment plug lead is applied to only individual style. Non plug-in has no junction cover.

VV5FS2-10-08-1-01-AP-Q

Series VFS2000
Manifold

Ordering source
area code

Code	areas
-	Japan, Asia Australia
E	Europe
N	North America

Base style/Wiring

01	Plug-in insert plug with lead wire
01T	Plug-in with terminal block
01C	Plug-in with multi-connector
01F	Plug-in with D-sub connector
10	Non plug-in

Connector mounting direction

Symbol	Connector mounting	Applicable base
-	None	01, 01T, 10
D	D side	01C, 01F
U	U side	

Junction cover

-	Individual style
1	Unit style

Individual: Base style 01, 01T
Unit: Base style 01T, 01C, 01F

*Option

The individual specification of the P port in the composition symbol marks 3 to 8 or EA, EB ports should be taken as individual port using a block plate. Therefore, if an individual port is taken using a single SUP spacer of option or a single EXH spacer, the composition symbol mark is "1".

Protective class
class I (Mark: ⊕)

Stations

02	2 stations
⋮	
15*	15 stations

*Base style 01, 01T, 10:
2 to 15 stations
01C, 01F: 2 to 8 stations

Symbol

Symbol	Port specifications		Porting
	P	EA, EB	
1			Side
2*	Common	Common	Bottom
3*			Side
4*	Common	Individual	Bottom
5*			Side
6*	Individual	Common	Bottom
7*			Side
8*	Individual	Individual	Bottom

Control unit

Control equipment	Symbol	-	A	AP	M	MP	F	G	C	E
Air filter with auto drain			●	●			●			
Air filter with manual drain					●	●		●		
Regulator			●	●	●	●	●	●		
Air release valve			●	●	●	●			●	●
Pressure switch				●		●				
Blank plate (Air release valve)							●	●		
Blank plate (Filter Regulator)									●	
Mounting manifold block			2 stations	2 stations	2 stations	2 stations	2 stations	2 stations	2 stations	1 station

Contact SMC
for other voltages (9)

Thread

-	Rc (PT)
N	NPT
T	NPTF
F	G (PF)

Port size

Symbol	P, EA, EB	A, B
01		1/8
02	1/4	1/4
M		Mix

Please indicate manifold base mounting style, corresponding valve, and option parts.

<<Example>>

•Plug-in with terminal block
(Manifold base) VV5FS2-01T1-091-02-MP-Q 1
(2 position single) VFS2100-5FZ-Q 5
(2 position double) VFS2200-5FZ-Q 2

*2 stations are needed to mount control unit.

•Non plug-in
(Manifold base) VV5FS2-10-071-01-M-Q 1
(2 position single) VFS2110-5D-Q 5

*2 stations are needed to mount control unit.

Splash Proof Manifold (Equivalent to IP65)

Manifold Specifications

Model	VV5FS2-01WTB ^U	VV5FS2-01W
Wiring	Common terminal box	Insert plug with lead wire
Applicable solenoid valve	VFS2□00-□F-X54	
Porting	Common SUP, Common EXH	
	A, B port	Side: 1/8 1/4 Bottom: 1/8 (Option)
	P, EA, EB port	Side: 1/4
Stations	2 to 10	2 to 15

How to Order

Manifold

VV5FS2-01WTBU-08-1-02-Q

• **Plug-in drip proof manifold (Equivalent to IP65)**

01WTBU	Common terminal box (U side mounting)
01WTBD	Common terminal box (D side mounting)
01W	Insert plug lead wire

• **Ordering source area code**

Code	areas
-	Japan, Asia Australia
E	Europe
N	North America

• **Stations**

02	2 stations
⋮	⋮
15	15 stations

• **Thread**

-	Rc (PT)
F	G (PF)
N	NPT
T	NPTF

• **Connecting port size**

Symbol	P, EA, EB	A, B
01	1/4	1/8
02		1/4
M		Mix

*Bottom porting: 1/8 only

• **Symbol**

Symbol	Port specifications	
	P, EA, EB	Porting
1	Common	Side
2*		Bottom

*Option

⚠ Protective class class I (Mark: )

Valve

VFS2-100-5F-X54-Q

• **Configuration**

1	2 position single
2	2 position double
3	3 position closed centre
4	3 position exhaust centre
5	3 position pressure centre
6	3 position double check

• **Pilot**

-	Internal pilot
R*	External pilot

*Option

• **Ordering source area code**

Code	areas
-	Japan, Asia Australia
E	Europe
N	North America

⚠ Protective class class I (Mark: )

• **Splash proof**

• **Pilot valve manual override**

-	Non-locking push style (Flush)
A*	Non-locking push style (Extended)
B*	Locking style (Slotted)
C*	Locking style (Lever)

*Option

• **Optional**

-	None
Z	With indicator light and surge voltage suppressor

• **Voltage**

1	100V AC 50/60Hz
2	200V AC 50/60Hz
3	110 to 120V AC 50/60Hz
4	220V AC 50/60Hz
5	24V DC
6	12V DC
7	240V AC 50/60Hz
9	Other, (250V or less)

 Contact SMC for other voltages (9)

VFS2000

Splash Proof Manifold

With common terminal box: VV5FS2-01WTB^U Station 1- Port size

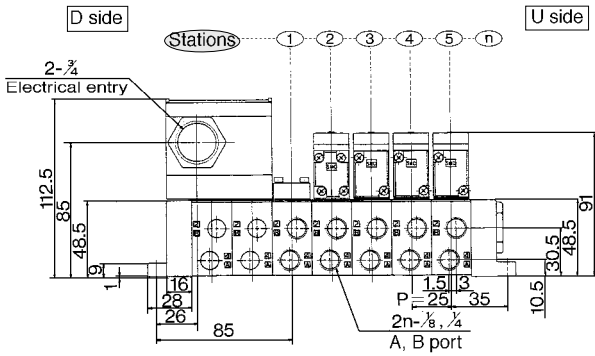

Bottom ported: VV5FS2-01WTBD- Station 2-01

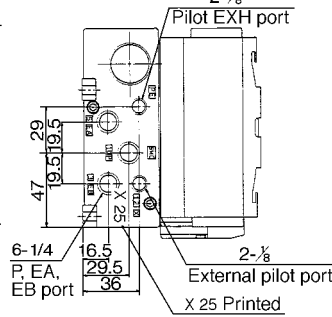
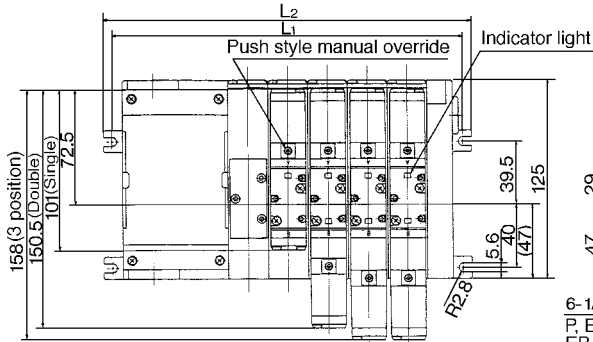
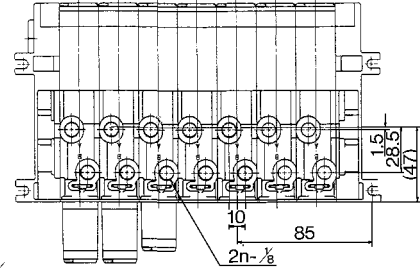

n: Station

n	1	2	3	4	5	6	7	8	9	10	Equation
L1	120	145	170	195	220	245	270	295	320	345	L1=25 X n+95
L2	131	156	181	206	231	256	281	306	331	356	L2=25 X n+106



*Terminal mounting stations are not included. Indicates Solenoid valve mounting stations.

With insert plug lead wire: VV5FS2-01W- Station 1- Port size

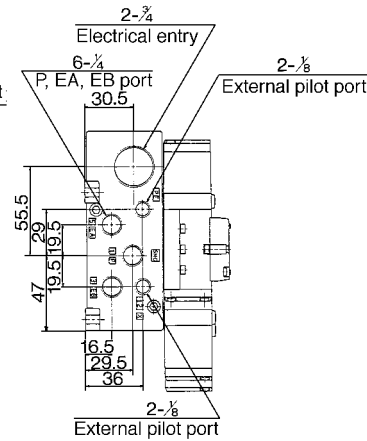
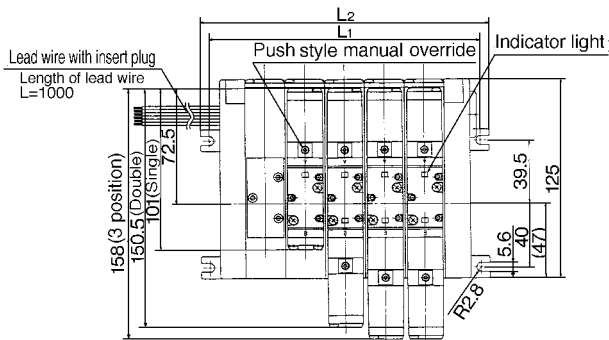

Bottom ported: VV5FS2-01W- Station 2-01

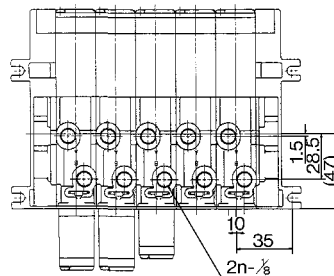
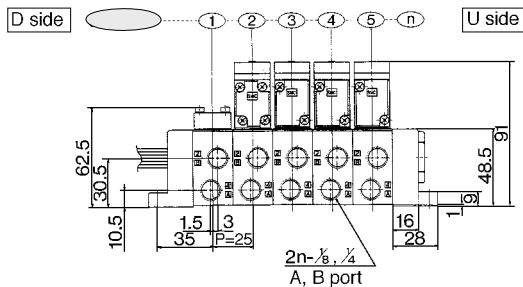

n: Station

n	1	2	3	4	5	6	7	8	9	10	11	12	13	14	15	Equation
L1	70	95	120	145	170	195	220	245	270	295	320	345	370	395	420	L1=25n+45
L2	81	106	131	156	181	206	231	256	281	306	331	356	381	406	431	L2=25n+56

Manifold Base Construction Plug-in/Non Plug-in

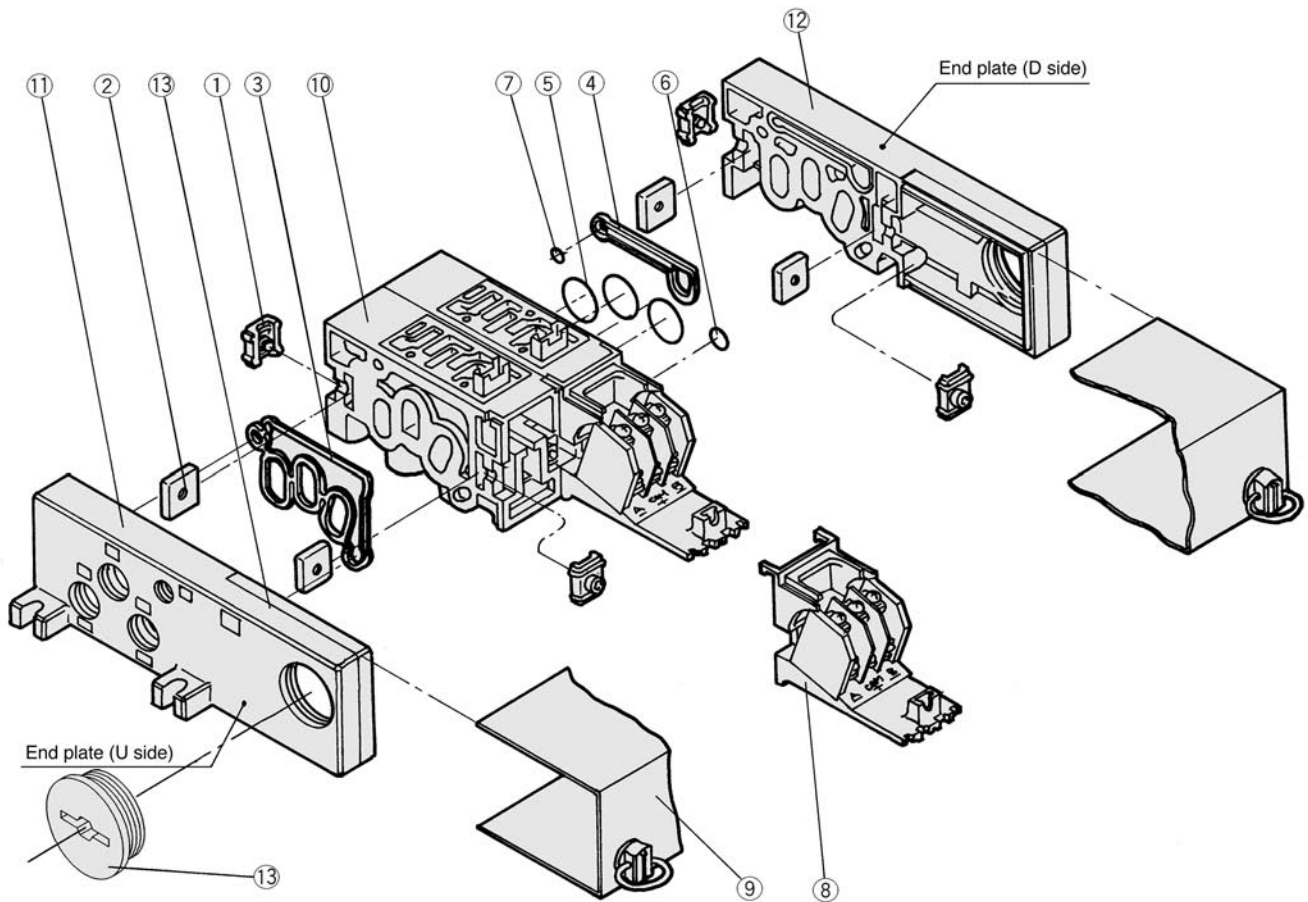

Replacement Parts

No.	Description	Material	Part No.
①	Metal joint A	Steel plate	AXT625-4-1
②	Metal joint B	Steel plate	AXT625-5
③	Gasket A	NBR	AXT625-17
④	Gasket B	NBR	AXT625-16
⑤	O ring	NBR	18 X 15 X 1.5
⑥	O ring	NBR	10.5 X 7.5 X 1.5
⑦	O ring	NBR	8 X 5 X 1.5
⑧	Adapter plate	Resin	01 AXT625-6
	Adapter plate assembly	—	01T AXT625-28-1A 01T1 (Terminal section with adapter plate)
⑩	Adapter plate	Resin	01C AXT625-28-1
			01F VVF2000-26-6
			01SU AXT625-6

No.	Description	Material	Part No.
⑨	Junction cover assembly	—	01 AXT625-7A
			01T AXT625-28-3A
			01T1 AXT625-28-7A-[stations]
			01C VVF2000-26-5A-[stations]
			01SU AZ738-10A-[stations]
⑪	Rubber plug Plug	NBR	01 AXT333-12
			01SU AXT625-22
			01W EXP22S

For increasing the manifold bases, please order the manifold block assembly number of the principal part assembly ⑩. For plug-in: The manifold base with terminal stand (integrated with a junction cover) is required with the ⑨ junction cover assembly.



Note) Manifold Base/Construction: Plug-in with terminal block.

Replacement Parts sub assembly

No.	Description	Ass'y part No.	Components parts	Applicable manifold base
⑩	Manifold block assembly	AXT625-01A- ¹ / ₂ ⁽¹⁾	Manifold block ⑩, Metal joint ①, ②, O ring ⑤, ⑥, ⑦ Junction cover, Adapter plate, Pin housing, Guide, Insert plug lead wire	Plug-in Insert plug with lead wire
		AXT625-20A- ¹ / ₂ ⁽¹⁾	Manifold block ⑩, Metal joint ①, ②, O ring ⑤, ⑥, ⑦ Terminal ⑧, Junction cover ⑨, Adaptor plate, Pin housing, Guide	Plug-in with terminal block
		AXT625-10A- ¹ / ₂ ⁽¹⁾	Manifold block ⑩, Metal joint ①, ②, O ring ⑤, ⑥, ⑦	Non plug-in
⑪	End plate (U side) assembly	AXT625-2A	End plate (U) ⑪, Metal joint ①, ②, Gasket A ③, Guard ⑬	Plug-in Insert plug with lead wire
		AXT625-2A-20	End plate (U) ⑪, Metal joint ①, ②, Gasket A ③, Guard ⑬	Plug-in with terminal block
		AXT625-2A-10	End plate (U) ⑪, Metal joint ①, ②, Gasket A ③, Guard ⑬	Non plug-in
⑫	End plate (D side) assembly	AXT625-3A	End plate (U) ⑫, Metal joint ①, ②, Gasket B ④, Guard ⑬ Steel ball	Plug-in Insert plug with lead wire
		AXT625-3A-20	End plate (U) ⑫, Metal joint ①, ②, Gasket B ④, Guard ⑬ Steel ball	Plug-in with terminal block
		AXT625-3A-10	End plate (U) ⑫, Metal joint ①, ②, Gasket B ④, Guard ⑬ Steel ball	Non plug-in

Note 1) A, B ports: 1/8, 1/4.

Light Compact Style Sub-plate/N_l/min: 589

N_l/min 589

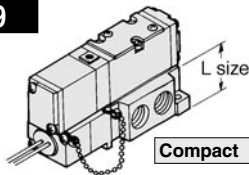

Compact

N_l/min 815

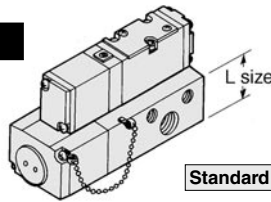

Standard

Sub-plate

Style	L (mm)	Weight (kg)	N _l /min Effective area ⁽¹⁾
Compact	25.5	0.13	10.8 (589)
Standard	31	0.2	15 (815)

Note 1) 2 position single. 1/4

Sub-plate

Compact: Plug-in/Grommet (Insert plug with lead wire)

VFS2□00-□F-P01, P02 Sub-plate assembly part No.: VFS2000-CP-⁰¹/₀₂ (01: 1/8, 02: 1/4)

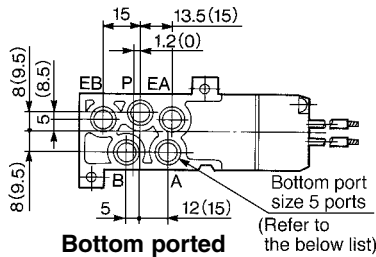

Bottom port size 5 ports (Refer to the below list)

Bottom ported

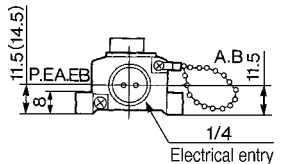

Electrical entry

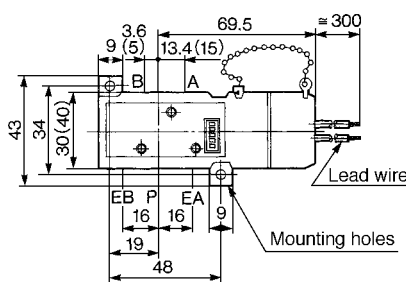

Mounting holes

Lead wire

Port size

Size	Port	P, A, B	EA, EB
P01		1/8	1/8
P02		1/4	1/8

Bottom ported size

Size	Port	P, A, B	EA, EB
P01		1/8	M5
P02		1/8, 1/4	1/8

(): Port size P02

Sub-plate

Compact: Non Plug-in

VFS2□10-□□-S01, S02 Sub-plate assembly part No.: VFS2000-CS-⁰¹/₀₂ (01: 1/8, 02: 1/4)

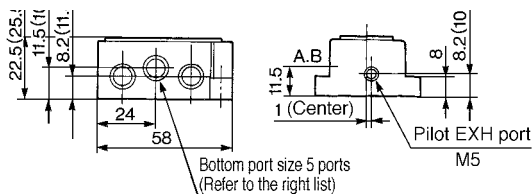

Bottom port size 5 ports (Refer to the right list)

Bottom ported

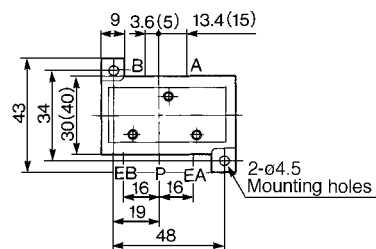

2-φ4.5 Mounting holes

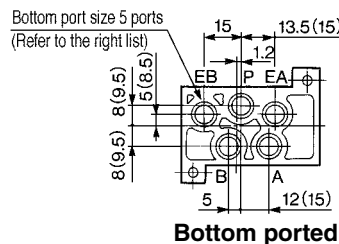

Bottom ported

Port size

Size	Port	P, A, B	EA, EB
S01		1/8	1/8
S02		1/4	1/8

Bottom ported size

Size	Port	P, A, B	EA, EB
S01		1/8	M5
S02		1/8, 1/4	1/8

(): Port size S02

Precaution

Please pay attention to piping port location of sub-plate.

VFS2□□0-□□-P01, 02 · Compact

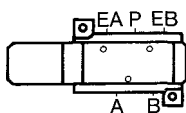

VFS2□□0-□□-⁰¹/₀₂ · Standard

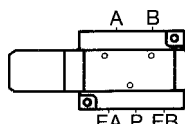

Wiring

Compact: Plug-in/Grommet (Insert plug with lead wire)

The insert plug is attached to the manifold block and lead wire is plugged in with valve side as shown in the following list. Please connect with corresponding power side.

Sol.	A side	B side
Lead wire colour	Red	Black
	Brown	White

No polarity.

5 Port Pilot/Metal Seal

Plug-in/Non Plug-in

Series VFS3000

Compact despite large flow capacity 3/8: Nl/min 1963

Small Power Consumption/1.8W DC

Easy to maintain

2 styles of sub-plates: plug-in and non plug-in

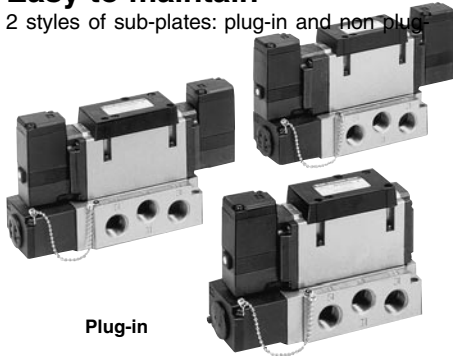

Plug-in



Non Plug-in

Model

Configuration	Model		Port size	Effective area (mm ²) (Nl/min)	Max. operating cycle (CPM) ⁽¹⁾	Response time (ms) ⁽²⁾	Weight (kg) ⁽³⁾	
	Plug-in	Non plug-in						
2 position	Single	VFS3100	VFS3110	1/4	32.4 (1767)	1200	20 or less	0.31
				3/8	36.0 (1963)			
	Double	VFS3200	VFS3210	1/4	32.4 (1767)	1500	15 or less	0.41
				3/8	36.0 (1963)			
3 position	Closed centre	VFS3300	VFS3310	1/4	32.4 (1767)	600	40 or less	0.43
				3/8	36.0 (1963)			
	Exhaust centre	VFS3400	VFS3410	1/4	32.4 (1767)	600	40 or less	0.43
				3/8	36.0 (1963)			
	Pressure centre	VFS3500	VFS3510	1/4	32.4 (1767)	600	40 or less	0.43
				3/8	36.0 (1963)			
	Double check	VFS3600	VFS3610	1/4	19.8 (1080)	600	50 or less	0.91
				3/8	21.6 (1178)			

- Note 1) According to JIS B8375 (Once per 30 days) for the minimum operating frequency.
 Note 2) According to JIS B8375-1981 (The value at supply pressure 0.5MPa.)
 Note 3) The figures in the above list are for without sub-plate. In the case of with plug-in sub-plate and with non plug-in sub-plate, therefore, add 0.30 kgf and 0.27 kgf sespectively.

Standard Specifications

	Fluid	Air and inert gas	
	Max. operating pressure	1.0MPa	
	Min. operating pressure	0.1MPa	
	Proof pressure	1.5MPa	
Valve	Ambient and fluid temperature	-10 to +60°C ⁽¹⁾	
	Lubrication	Not required ⁽²⁾	
	Pilot valve manual override	Non-locking push (Flush)	
	Shock/vibration resistance	150/50m/s ² ⁽³⁾	
	Protection structure	E type: Dust proof (level 0), F type: drip proof (level 2), D type: splash proof (level 4) ⁽⁴⁾	
	Rated voltage	100V, 200V AC 50/60Hz, 24V DC	
	Allowable voltage	-15 to +10% rated voltage	
Solenoid	Coil insulation	Class B or equivalent (130°C) ⁽⁵⁾	
	Apparent power (Power consumption) AC	Inrush	5.6VA/50Hz, 5.0VA/60Hz
		Holding	3.4VA (2.1W)/50Hz, 2.3VA (1.5W)/60Hz
	Power consumption DC	1.8W	
	Electrical entry	Plug-in	Conduit terminal
	Non plug-in	DIN connector	

- Note 1) Use dry-air at low temperatures.
 Note 2) Use turbine oil No.1 (ISO VG32), if lubricated.
 Note 3) Shock resistance: No malfunction from test using drop impact tester, to axis and right angle directions of main valve and armature, each one time when energized and de-energized. (Value in the initial stage.)
 Vibration resistance: No malfunction from test with 8.3 to 2000Hz 1 sweep, to axis and right angle directions of main valve and armature, each one time when energized and de-energized. (Value in the initial stage.)
 Note 4) According to JIS C0920. Note 5) According to JIS C4003.

JIS Symbol

2 position	3 position
Single	Closed centre
Double	Exhaust centre
	Pressure centre
	Double check

Option Specifications

Pilot		External pilot style ⁽¹⁾
Manual override	Main valve	Direct manual override style
	Pilot valve	Non-locking push style (Extended), Locking style (Slotted), Locking style (Lever)
Voltage		110V to 120V, 220V, 240V AC (50/60Hz)
Porting		12V, 100V DC
Option		Bottom porting
		With indicator light and surge voltage suppressor

- Note 1) Operating pressure: 0 to 1.0MPa Pilot pressure ——— 0.1 to 1.0MPa

VFS3000

How to Order

Ordering source area code

Code	areas
-	Japan, Asia Australia
E	Europe
N	North America

Body

O: Plug-in sub-plate

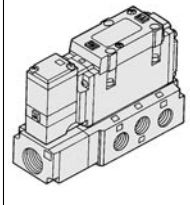

Electrical entry

F: Plug-in conduit with terminal

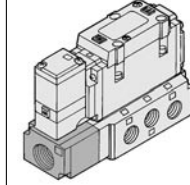

Porting

-	Side
B*	Bottom

*Option

Port size

-	Without sub-plate
02	1/4
03	3/8

*Bottom ported: Only 1/4.

Thread

-	Rc (PT)
N	NPT
T	NPTF
F	G (PF)



Plug-in

VFS3 1 0 0 1 F 02 Q

Non plug-in

VFS3 2 1 1 2 D 02 Q

Option

-	None
Z	With indicator light and surge voltage suppressor

Electrical entry

D: DIN connector
DO: Without connector

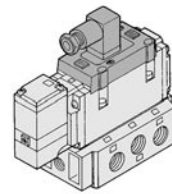

Y: DIN connector (DIN 43650)
YO: Without DIN connector

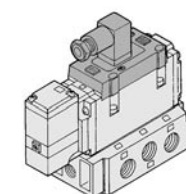

Voltage

1	100V AC (50/60Hz)
2	200V AC (50/60Hz)
3	110V to 120V AC (50/60Hz)
4	220V AC (50/60Hz)
5	24V DC
6	12V DC
7	240V AC (50/60Hz)
9	Other, (250V or less)

Contact SMC for other voltages (9)

Pilot

-	Internal
R*	External

*Option

Pilot valve manual override

-: Non-locking push style (Flush)

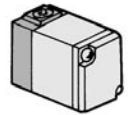

A*: Non-locking push style (Extended)

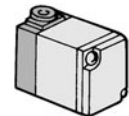

B*: Locking style (Slotted)

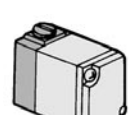

C*: Locking style (Lever)

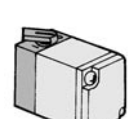

*Option

Configuration

1	2 position single 	5	3 position pressure centre
2	2 position double 	6	3 position double check
3	3 position closed centre 		
4	3 position exhaust centre 		

*External pilot style can be used when using with reverse pressure.

Body

1: Non plug-in sub-plate

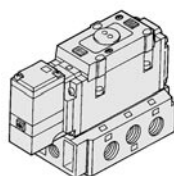

Body option

0	Standard
1*	Direct manual override

*Option

Protective class class I (Mark:)

How to Order Pilot Valve Assembly

SF4 - 1 F - 30-Q

Voltage

1	100V AC (50/60Hz)
2	200V AC (50/60Hz)
3	110V to 120V AC (50/60Hz)
4	220V AC (50/60Hz)
5	24V DC
6	12V DC
7	240V AC (50/60Hz)
9	Other, (250V or less)

Contact SMC for other voltages (9)

Manual override

Symbol	Classification
-	Non-locking push style (Flush)
A*	Non-locking push style (Extended)
B*	Locking style (slotted)
C*	Locking style (lever)

*Option



*Refer to p.1.17-5 for voltage conversion.

Maximum Cylinder Speed

System diagram

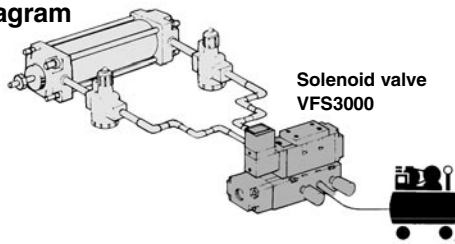

Rubber hose piping sys- Conditions: Supply pressure 0.5MPa, Load factor 50%

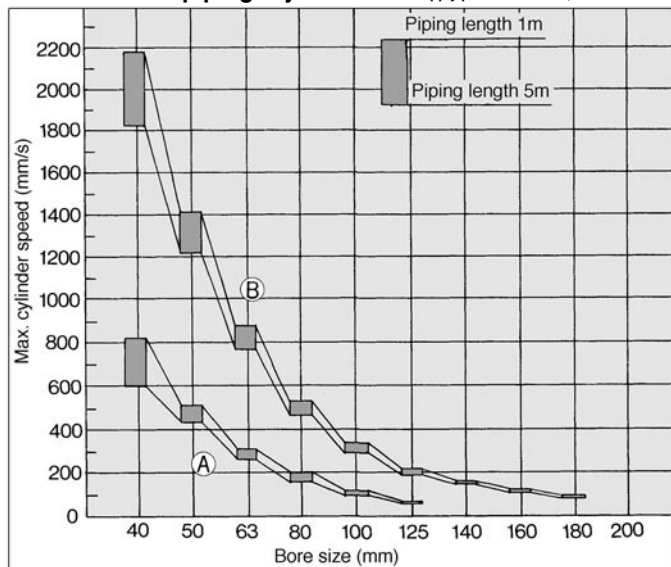

System	Solenoid valve	Speed controller	Silencer	Fitting (Hose I. D. X Fitting I. D. X Port Size)
A	VFS3000-02 1/4 (S=32.4mm ²)	AS4000-02 (S=24mm ²)	AN200-02 (S=35mm ²)	ø6.3 X ø4.8 X 1/4
B	VFS3000-03 3/8 (S=36mm ²)	AS420-03 (S=73mm ²)	AN300-03 (S=60mm ²)	ø9.5 X ø8 X 3/8

S. G. P. piping system Conditions: Supply pressure 0.5MPa, Load factor 50%

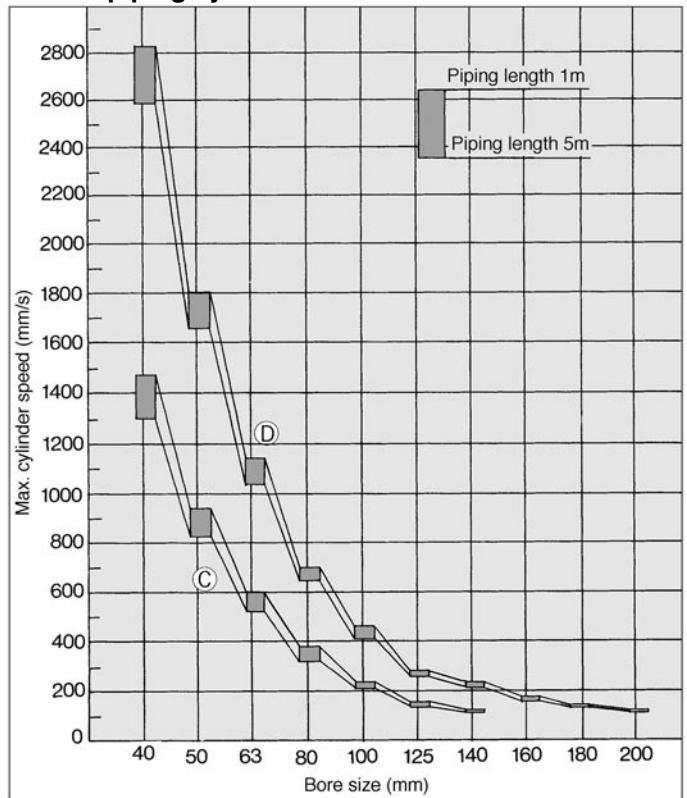

System	Solenoid valve	Speed controller	Silencer	Fitting
C	VFS3000-02 1/4 (S=32.4mm ²)	AS4000-02 (S=24mm ²)	AN200-02 (S=35mm ²)	Elbow 90° 5 pcs.
D	VFS3000-03 3/8 (S=36mm ²)	AS420-03 (S=73mm ²)	AN300-03 (S=60mm ²)	Elbow 90° 5 pcs.

Double Check Spacer/Specification

Holding cylinder mid-position for long periods.

The concurrent use of double check spacer with built-in double check valve can stop cylinder or mid-position and hold it without being affected by air leakage spool seals.

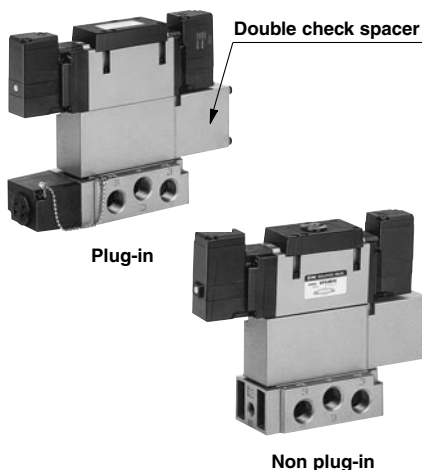

Specifications

Double check spacer	Plug-in	Non plug-in
	VVFS3000-22A-1	VVFS3000-22A-2
Applicable solenoid valve	VFS3400-□F	VFS3410-□D VFS3410-□E
Leakage* (cm ³ /min)	Solenoid one side energized	P EA 230 or less
		P EB 230 or less
	Solenoid both side de-energized	A EA 0
		B EB 0

*Supply pressure: 0.5MPa

⚠ Precaution

- In the case of 3 position double check valve (VFS36□0), check the leakage from piping and fittings in between valve and cylinder by means of synthetic detergent solutions, and ensure that there is no such leakage found there. Also check the leakage from cylinder seal and piston seal.
If there is any leakage, sometimes the cylinder, when valve is de-energized, can move without stopping at mid-position.
- Be aware that if the exhaust side is restricted excessively, the intermediate stopping accuracy will decrease and will lead to improper intermediate stops.

Check Valve Operation

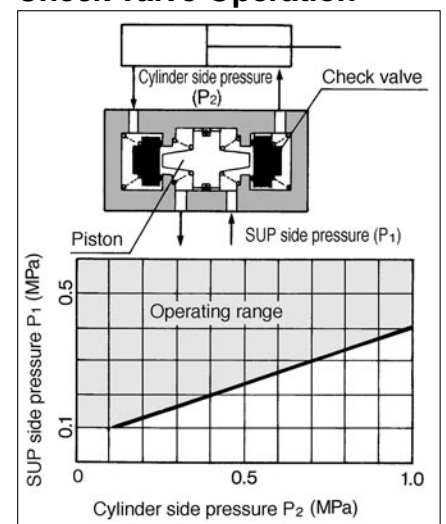

- The combination of VFS31 0/0, VFS32 0/0 and a double check spacer can be used as prevention of falling at the stroke end but cannot hold the intermediate position of the cylinder.

VFS3000

Construction

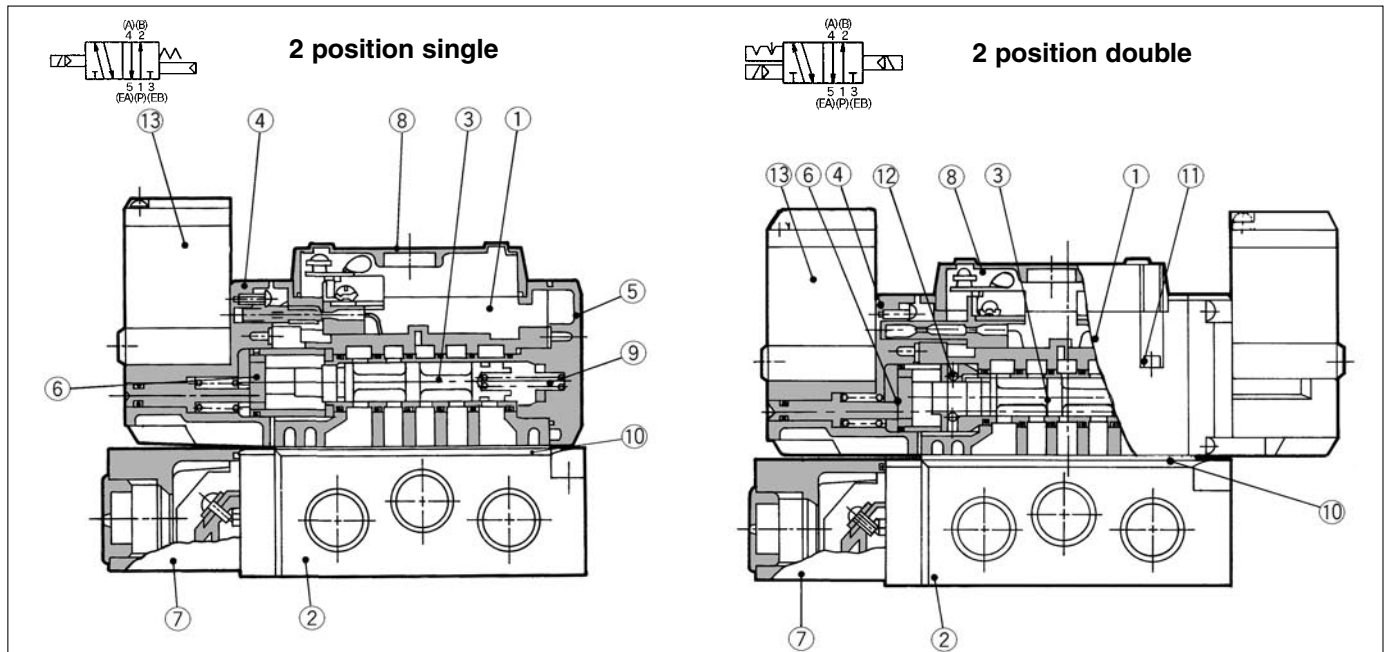

3 position closed centre/exhaust centre/pressure centre

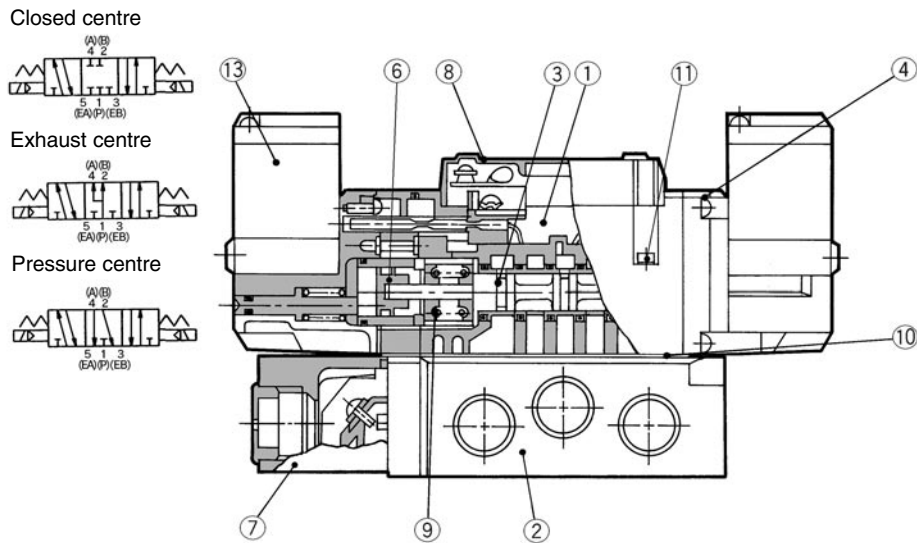

Component Parts

No.	Description	Material	Note
①	Body	Aluminium die-cast	Platinum silver
②	Sub plate	Aluminium die-cast	Platinum silver
③	Spool/Sleeve	Stainless steel	—
④	Adaptor plate	Resin	Black
⑤	End plate	Resin	Black
⑥	Piston	Resin	—
⑦	Junction cover	Resin	—
⑧	Light cover	Resin	—

Sub-plate Assembly

Plug-in	VFS3000-P- ⁰² / ₀₃
Non plug-in	VFS3000-S- ⁰² / ₀₃



*Without mounting screw and gasket.

Replacement Parts

No.	Description	Material	Part No.		
			VFS31□□	VFS32□□	VFS33□□, 34□□, 35□□
⑨	Return spring	Stainless steel	VFS3000-17-1	—	VFS3000-17-2
⑩	Gasket	NBR	VFS3000-20	VFS3000-20	VFS3000-20
⑪	Hexagonal socket head cap screw	Steel	M3 X 32	M3 X 32	M3 X 32
⑫	Detent assembly	—	—	VFS3000-9A	—
⑬	Pilot valve assembly	—	—	—	—

Refer to "How to order Pilot valve assembly" on p.1.17-54.

Plug-in 2 Position Single, 3 Position Closed Centre/Exhaust Centre/Pressure Centre/Double Check

2 position single: VFS3100-□F

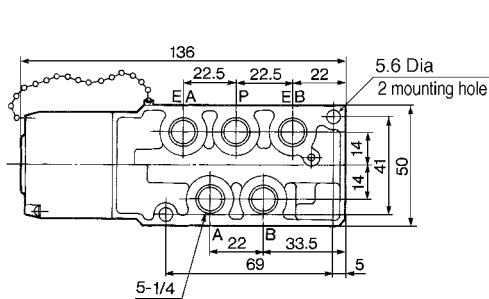

Bottom Ported

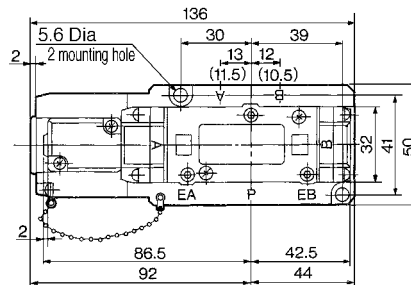
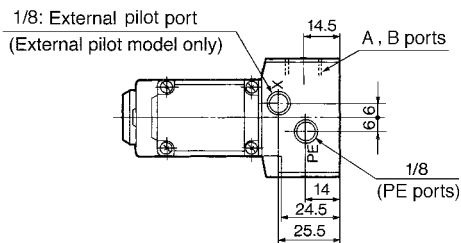
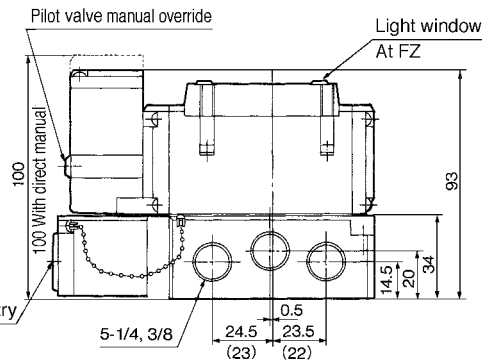

2 position double: VFS3200-□F

3 position closed centre: VFS3300-□F

3 position exhaust centre: VFS3400-□F

3 position pressure centre: VFS3500-□F

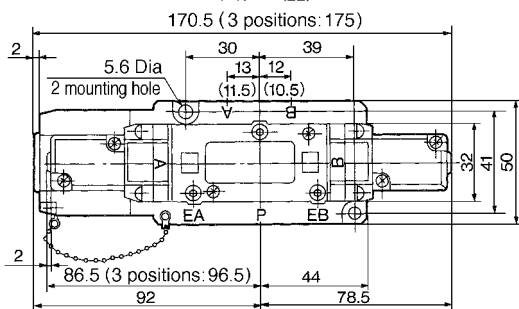
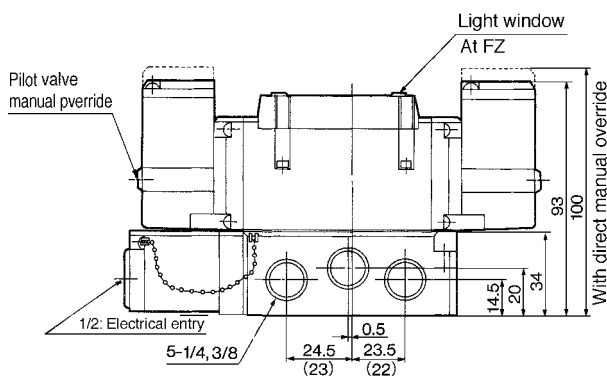

3 position double check: VFS3600-□F

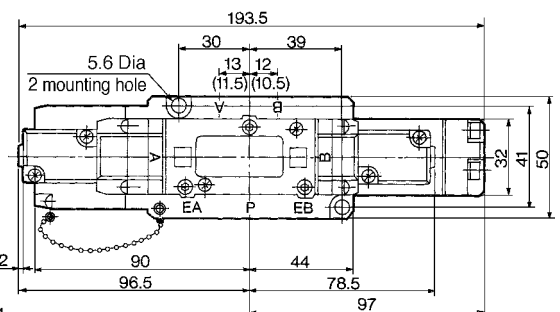
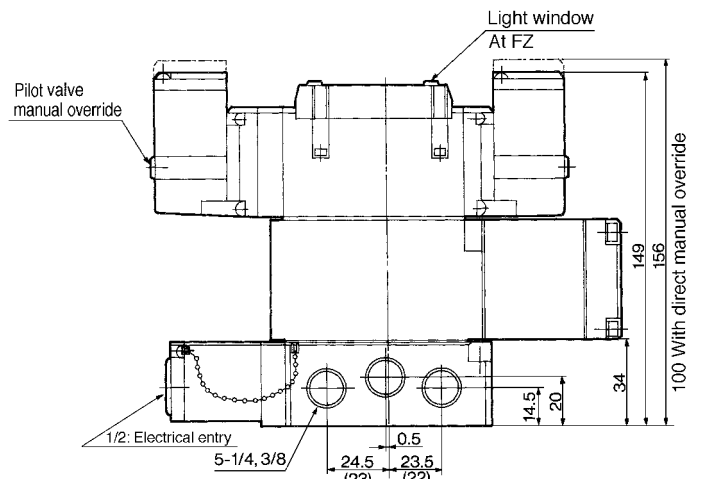

VFS3000

Non Plug-in 2 Position Single/Double, 3 Position Closed Centre/Exhaust Centre/Pressure Centre/Double Check

2 position single: VFS3110-□E, VFS3110-□D

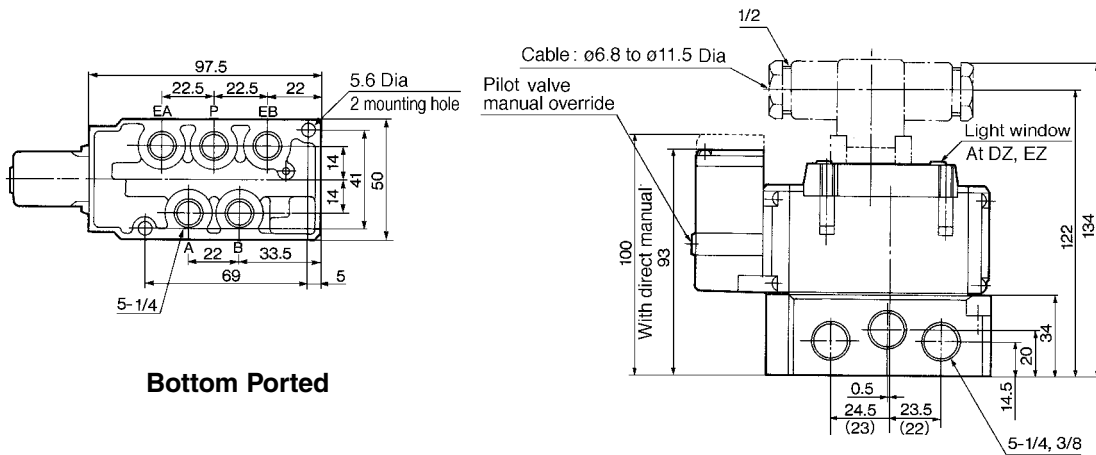

Bottom Ported

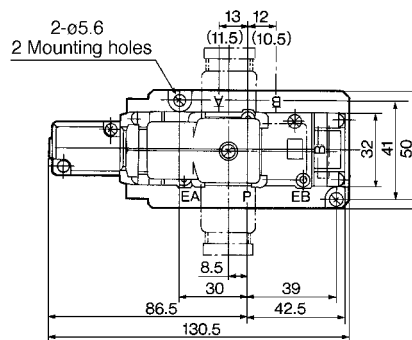
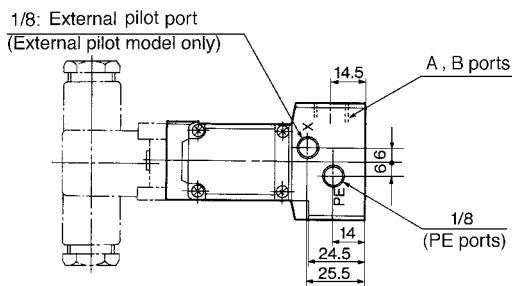

2 position double: VFS3210-□E, VFS3210-□D

3 position closed centre: VFS3310-□E, VFS3310-□D

3 position exhaust centre: VFS3410-□E, VFS3410-□D

3 position pressure centre: VFS3510-□E, VFS3510-□D

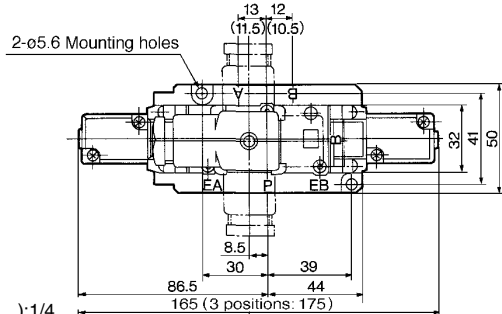
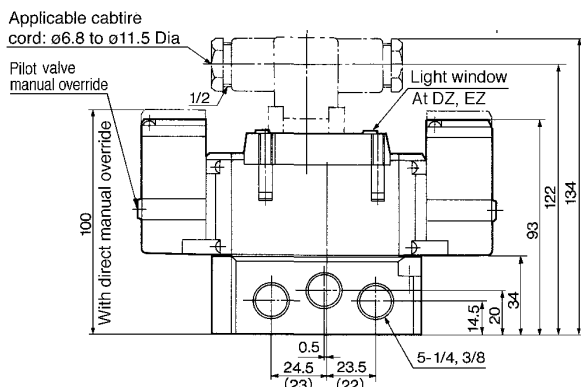

3 position double check: VFS3610-□E, VFS3610-□D

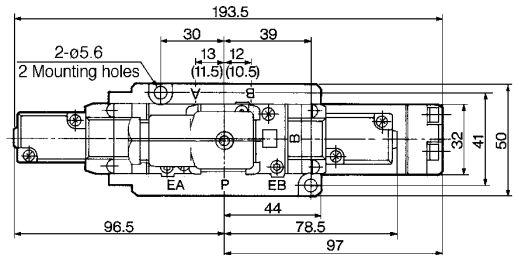
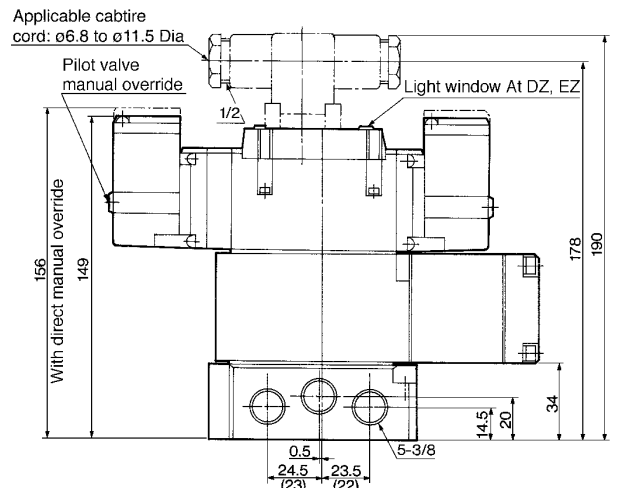

Series VFS3000 Manifold

Plug-in: With Terminal Block

•Since lead wires of solenoid valve are connected with the terminals on upper surface of terminal block, corresponding lead wires from power source can be wired at the bottom of terminal block.

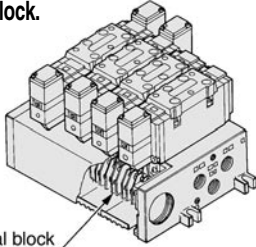

Terminal block

Ordering code: **VV5FS3 - 01T - 06 1 - 02 - Q**

Series VFS3000 Manifold

Plug-in with terminal block

Ordering source area code

Code	areas
-	Japan, Asia Australia
E	Europe
N	North America

Stations

02	2 stations
⋮	⋮
10	10 stations

Port size

Symbol	P, EA, EB	A, B
02		1/4
03	1/2	3/8
M		Mix

Thread

	Rc (PT)
N	NPT
T	NPTF
F	G (PF)

Symbol

Symbol	Port specifications	Porting (A, B)
1	Common	Side
2	Common	Bottom* *Option

Plug-in: With Multi Connector

(Wiring specifications: Please refer to p.1.17-8.)

•Master connection of power and solenoid valves.
•Quick wiring permits easier installation.

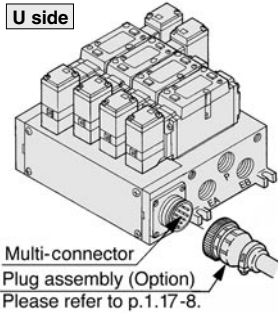

Multi-connector
Plug assembly (Option)
Please refer to p.1.17-8.

Ordering code: **VV5FS3 - 01C D - 05 2 - 02 - Q**

Series VFS3000 Manifold

Plug-in with multi-connector

Ordering source area code

Code	areas
-	Japan, Asia Australia
E	Europe
N	North America

Mounting direction of connector

D	D side mounting
U	U side mounting

Stations

02	2 stations
⋮	⋮
08*	8 stations

*Max: 8 stations

Port size

Symbol	P, EA, EB	A, B
02		1/4
03	1/2	3/8
M		Mix

Thread

	Rc (PT)
N	NPT
T	NPTF
F	G (PF)

Symbol

Symbol	Port specifications	Porting (A, B)
1	Common	Side
2	Common	Bottom* *Option

Plug-in: With D-Sub Connector

(Wiring specifications: Please refer to p.1.17-8.)

•Wide range of interchangeability (MIL Spec DIN connector terminal 25 pcs attached.)
•Quick wiring permits ease of installation.

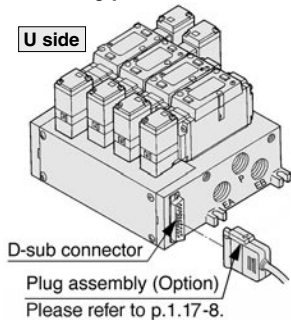

D-sub connector
Plug assembly (Option)
Please refer to p.1.17-8.

Ordering code: **VV5FS3 - 01F D - 06 1 - 02 - Q**

Series VFS3000 Manifold

Plug-in with D-sub connector

Ordering source area code

Code	areas
-	Japan, Asia Australia
E	Europe
N	North America

Mounting direction of connector

D	D side mounting
U	U side mounting

Stations

02	2 stations
⋮	⋮
08*	8 stations

*Max: 8 stations

Port size

Symbol	P, EA, EB	A, B
02		1/4
03	1/2	3/8
M		Mix

Thread

	Rc (PT)
N	NPT
T	NPTF
F	G (PF)

Symbol

Symbol	Port specifications	Porting (A, B)
1	Common	Side
2	Common	Bottom* *Option

Non Plug-in: DIN Connector

•Wiring for every valve

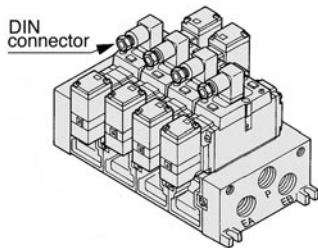

DIN connector

Ordering code: **VV5FS3 - 10 - 05 2 - 02 - Q**

Series VFS3000 Manifold

Non Plug-in

Ordering source area code

Code	areas
-	Japan, Asia Australia
E	Europe
N	North America

Stations

02	2 stations
⋮	⋮
10	10 stations

Port size

Symbol	P, EA, EB	A, B
02		1/4
03	1/2	3/8
M		Mix

Thread

	Rc (PT)
N	NPT
T	NPTF
F	G (PF)

Symbol

Symbol	Port specifications	Porting (A, B)
1	Common	Side
2	Common	Bottom* *Option

VFS3000

Manifold Specifications

Base style	Wiring	Porting	Port size		No. of stations	Applicable solenoid valve
		A, B port	P, EA, EB	A, B		
Plug-in VV5FS3-01□	<ul style="list-style-type: none"> •With terminal block •With multi-connector •With D-sub connector 	Side, Bottom	1/2 ⁽¹⁾	1/4, 3/8	2 to 10 ⁽²⁾	VFS3□00-□F
Non plug-in VV5FS3-10	<ul style="list-style-type: none"> •DIN Connector •Grommet terminal 					VFS3□10-□D

Note 1) Appropriate silencer for EA, EB port: "AN403-04" (O.D.φ27).
 Note 2) With multi-connector, or with D-sub connector: 8 stations max.

Manifold Stations and Effective Area (mm²) (N/min)

Porting/No. of stations	First station	Fifth station	Tenth station
P → A or B	34.2 (1865)	32.4 (1767)	32.4 (1767)
A → EA, B → EB	39.6 (2159)	37.8 (2061)	37.8 (2061)

* Port size: 3/8

Manifold/Option Parts Assembly

Individual SUP spacer

An individual SUP spacer set on manifold block can form SUP port for every valve.

Body	Plug-in	Non plug-in
Part No.	VVFS3000-P-03-1	VVFS3000-P-03-2

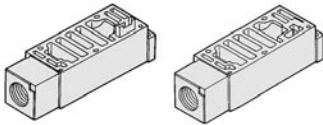

Individual EXH spacer

An individual EXH spacer set on manifold block can form EXH port for every valve.

Body	Plug-in	Non plug-in
Part No.	VVFS3000-R-03-1	VVFS3000-R-03-2

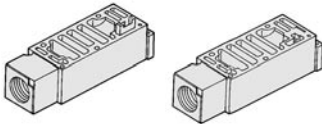

SUP block disk *

When supplying manifold with more than two different pressures, high and low, insert a block plate in between stations subjected to different pressures.

Body	Plug-in	Non plug-in
Part No.	AXT636-1A	

EXH block disk *

When valve exhaust affects the other stations on the circuit or when the reverse pressure valve is used to standard manifold valve, insert EXH block plate between stations to separate valve exhaust.

Body	Plug-in	Non plug-in
Part No.	AXT636-1A	



Interface speed control

Needle valve set on the manifold block can control cylinder speed by throttling exhaust.

Body	Plug-in	Non plug-in
Part No.	VVFS3000-20A-1	VVFS3000-20A-2

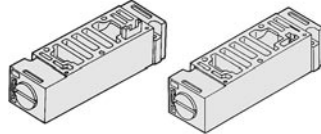

Double check spacer

The concurrent use of double check spacer with built-in double check valve can stop the cylinder at mid-position and hold for a long time without being affected by the air leakage across spool seals.

Body	Plug-in	Non plug-in
Part No.	VVFS3000-22A-1	VVFS3000-22A-2

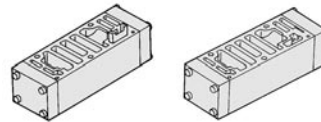

Interface regulator

Interface regulator set on manifold block can regulate the pressure to each valve. Refer to p.1.17-6 for flow characteristic.

Body	Plug-in	Non plug-in
P regulation	ARBF3050-00-P-1	ARBF3050-00-P-2
A regulation	ARBF3050-00-A-1	ARBF3050-00-A-2
B regulation	ARBF3050-00-B-1	ARBF3050-00-B-2

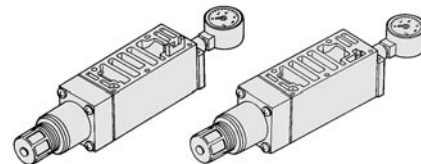

Blank plate

When disassembling valve for maintenance purposes or when spare manifold stations are required, install a blank plate on the manifold block.

Body	Plug-in	Non plug-in
Part No.	VVFS3000-10A	

How to Order Manifold

Please indicate manifold base style, corresponding valve, and option parts.

<<Example>>

•Plug-in with terminal block — 6 stations
 (Manifold base) VV5FS3-01T-061-02 1
 (2 position single) VFS3100-5FZ 3
 (2 position double) VFS3200-5FZ 2
 (Blank plate) VVFS3000-R-03-2 1

<<Example>>

•Non Plug-in with terminal block — 6 stations
 (Manifold base) VV5FS3-10-061-03 1
 (2 position single) VFS3110-5D 5
 (3 position exhaust centre) VFS3410-5D 1
 (Individual EXH spacer) VVFS300-R-03-2 1

Manifold Options

With exhaust cleaner

Plug-in/Non plug-in

- Valve exhaust noise dampening: 35dB or more.
- Oil mist collection: Rate of collection 99.9% or more.
- Piping hours reduced.

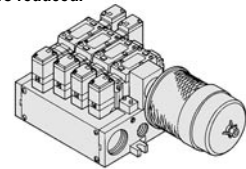

For more information, please refer to p.1.17-63.

With control unit

Plug-in/Non plug-in

- Filter, regulation valve, pressure switch and air release valve are all combined to form one unit.

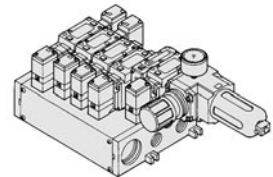

For more information, please refer to p.1.17-65.

With serial interface unit

Plug-in

- Solenoid valve wiring process reduced considerably.
- Disperse installation possible. Manifold solenoid valve: 8 stations max, 32 positions (512 solenoids).
- Maintenance and inspection are easy.

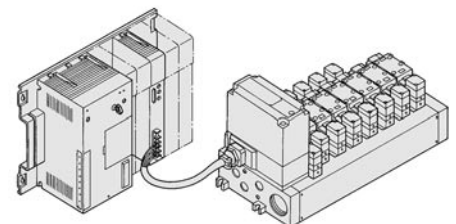

Manifold Plug-in/Non Plug-in

Plug-in (with terminal block): VV5FS3-01T- Station 1- Port size

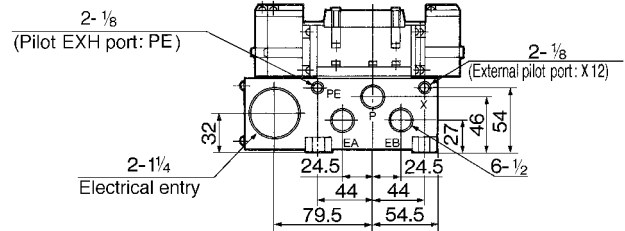

Bottom ported: VV5FS3-01T- Station 2- Port size

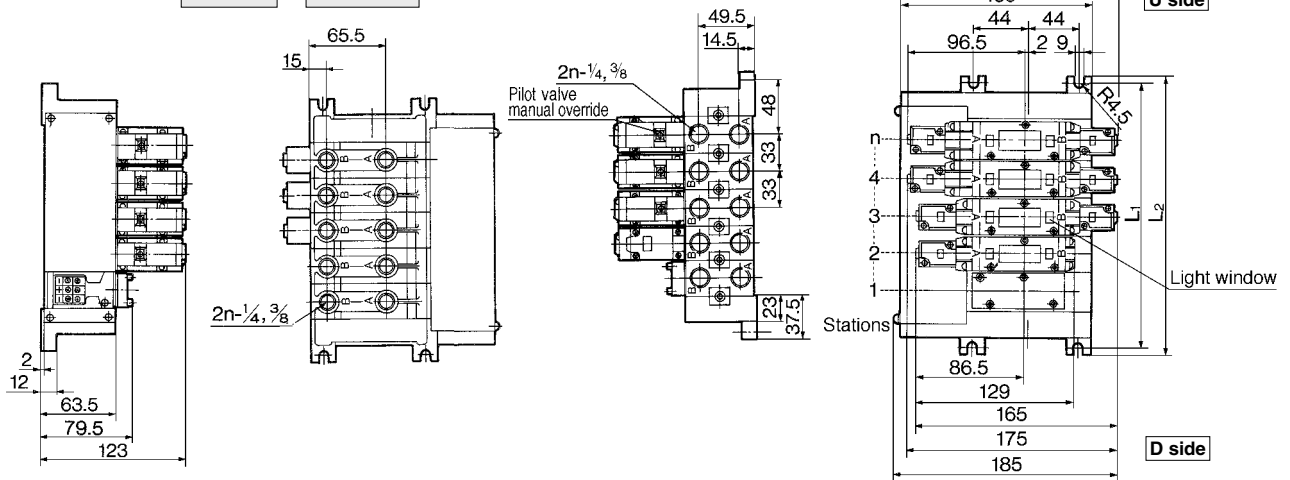

General formula of weight $M=0.405n+0.665$ (kg) n: Station

Non plug-in: VV5FS3-10- Station 1- Port size

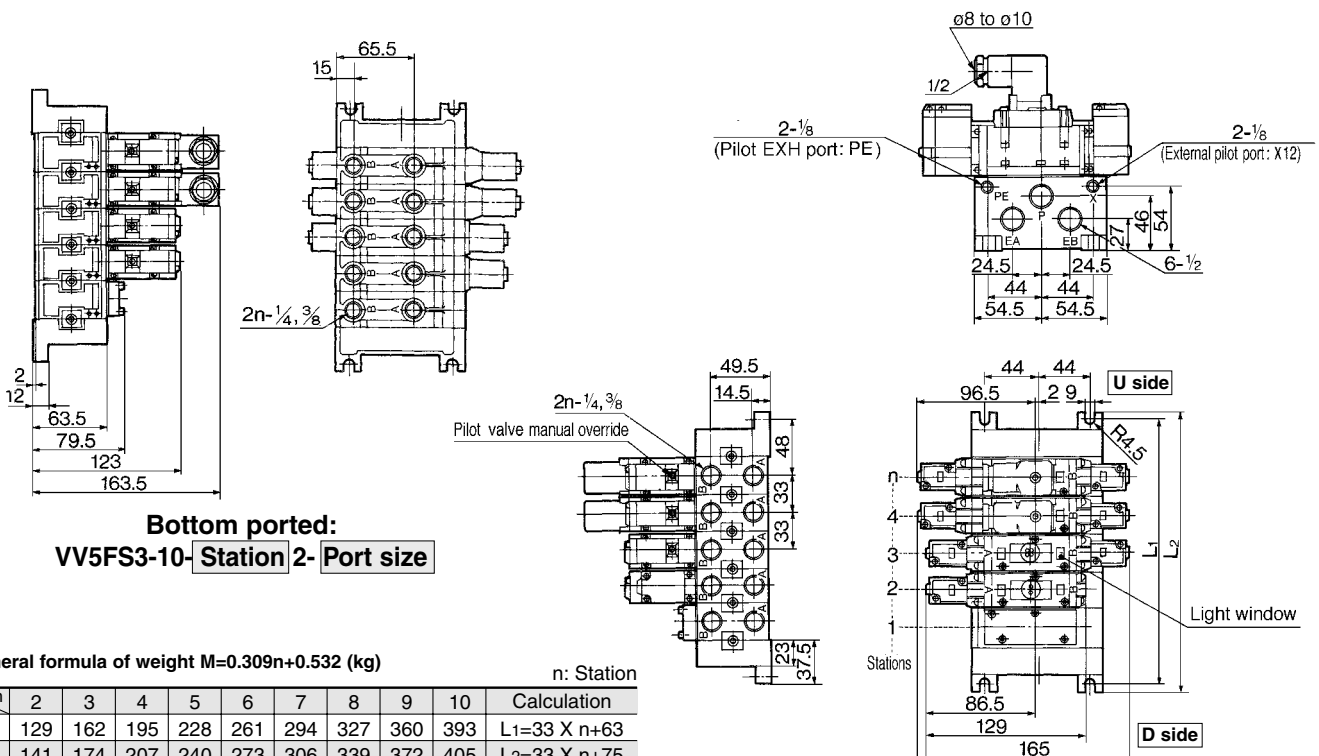

Bottom ported: VV5FS3-10- Station 2- Port size

General formula of weight $M=0.309n+0.532$ (kg)

n: Station

L \ n	2	3	4	5	6	7	8	9	10	Calculation
L1	129	162	195	228	261	294	327	360	393	$L1=33 \times n+63$
L2	141	174	207	240	273	306	339	372	405	$L2=33 \times n+75$

VFS3000

Manifold Plug-in with Multi-connector/With D-sub connector

Plug-in with multi-connector: VV5FS3-01CD- Station 1- Port size, VV5FS3-01CU- Station 1- Port size

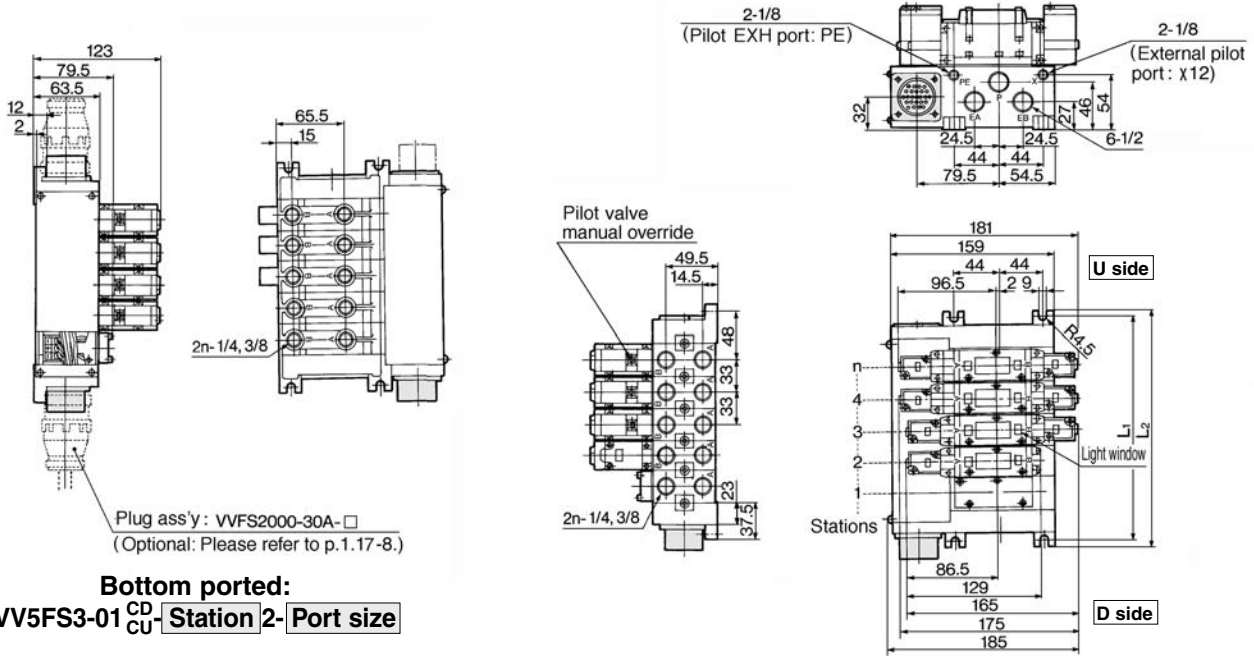

General formula of weight/Manifold $M=0.41n+0.753$ (kg) n: Station

* For Wiring specifications, please refer to p.1.17-8.



Plug-in with D-sub connector: VV5FS3-01FD- Station 1- Port size, VV5FS3-01FU- Station 1- Port size

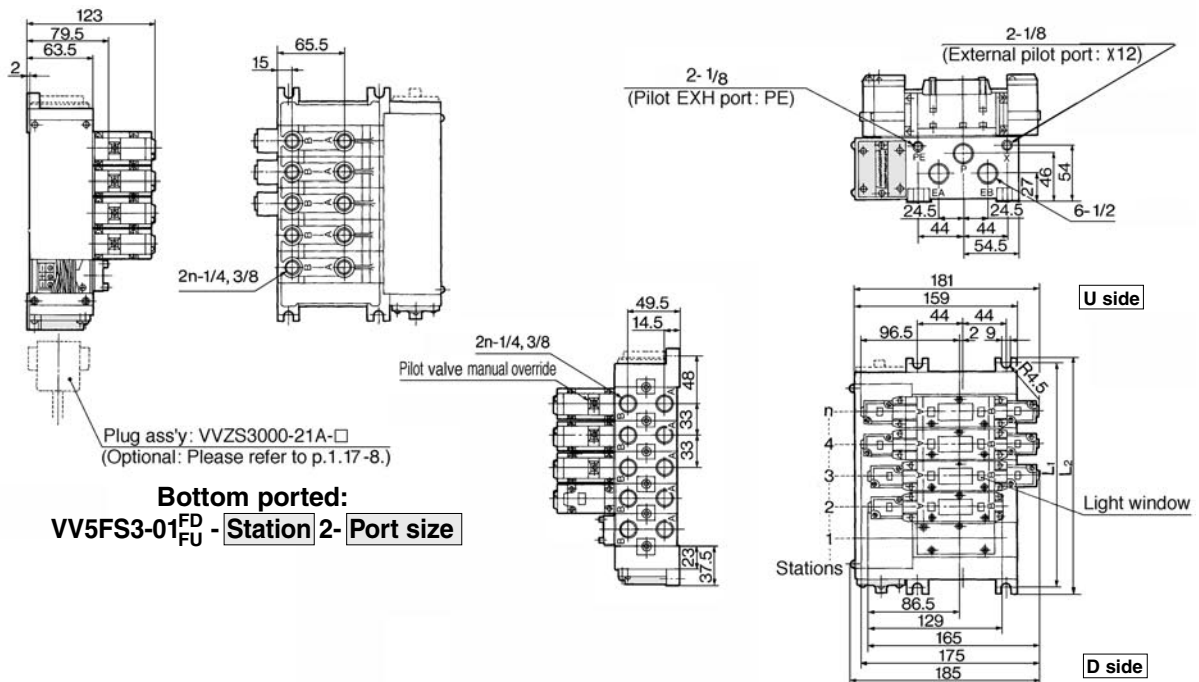

G

L
L

Manifold with Exhaust Cleaner

- Serves to protect work environment.
- Valve exhaust noise dampening: 35dB or more.
- Collection rate of drainage and oil mist: 99.9% or more.
- Piping process reduced.

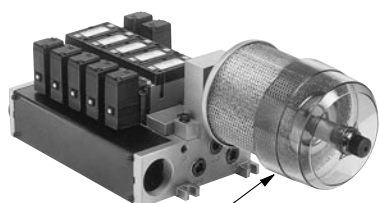

Plug-in

Exhaust cleaner AMC610-10 (Optional)

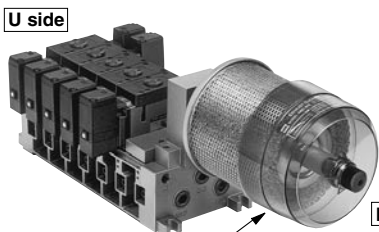

Non plug-in

Exhaust cleaner AMC610-10 (Optional)

Manifold Specifications

Manifold style	Plug-in: VV5FS3-01□	Non plug-in: VV5FS3-10
Wiring	With terminal block board With multi-connector With D-sub connector	DIN connector
Applicable valve	VFS3□00-□F	VFS3□10-□D
Porting	Common SUP, Common EXH	
	A, B Port	1/4, 3/8
	P, EA, EB port	P: 1/2, EXH: 1
No. of stations	2 to 10 ⁽¹⁾	
Applicable exhaust cleaner	AMC610-10 (Connecting port size 1) ⁽²⁾	

Note 1) With multi-connector, or with D-sub connector: 8 stations maximum.
Note 2) Exhaust cleaner "AMC610-10" is not attached.

How to Order

Ordering Code: VV5FS3-10-06-1-03-CD-Q

Series VFS3000 Manifold

Ordering source area code

Code	areas
-	Japan, Asia Australia
E	Europe
N	North America

Base style/Wiring

01T	Plug-in With terminal block
01C	Plug-in With multi-connector
01F	Plug-in With D-sub connector
10	Non plug-in

Connector mounting direction

Symbol	With connector	Applicable base mounted
-	None	01T, 10
D	D-side mounting	01C, 01F
U	U side mounting	

Thread

-	Rc (PT)
N	NPT
T	NPTF
F	G (PF)

Port size

Symbol	P	A, B
02	1/2	1/4
03		3/8
M		Mix

Exhaust cleaner mounting direction

Symbol	Exhaust cleaner mounting direction	
CD	D side	D side mounting
CU	U side	U side mounting

Stations

02	2 stations
⋮	⋮
10	10 stations

Symbol

Symbol	Port specifications		Porting (A, B)
	P	EA, EB	
1	Common	Common	Side
2	Common	Common	Bottom*

*Option

Base style 01T, 10: 2 to 10 stations
Base style 01C, 01F: 2 to 8 stations

⚠ Precautions

When using exhaust cleaner, mount it downwards.



*Refer to p.5-3-1 for details on exhaust cleaners.

Please indicate manifold base mounting style, corresponding valve, and option parts.

<<Example>>

Plug-in with terminal block (6 stations)
(Manifold base) **VV5FS3-01T-061-03-CD-Q** 1
(2 position single) **VFS3100-5FZ-Q** 3
(2 position double) **VFS3200-5FZ-Q** 2
(Blank plate) **VVFS3000-10A** 1
(Exhaust cleaner) **AMC610-10** 1

Non plug-in (6 stations)
(Manifold base) **VV5FS3-10-061-03-CU-Q** 1
(2 position single) **VFS3110-5D-Q** 3
(2 position double) **VFS3210-5D-Q** 2
(Blank plate) **VVFS3000-10A** 1
(Exhaust cleaner) **AMC610-10** 1

VFS3000

Manifold for Exhaust Cleaner Plug-in/Non plug-in

Plug-in: VV5FS3-01T- Station 1- Port size $\frac{CD}{CU}$

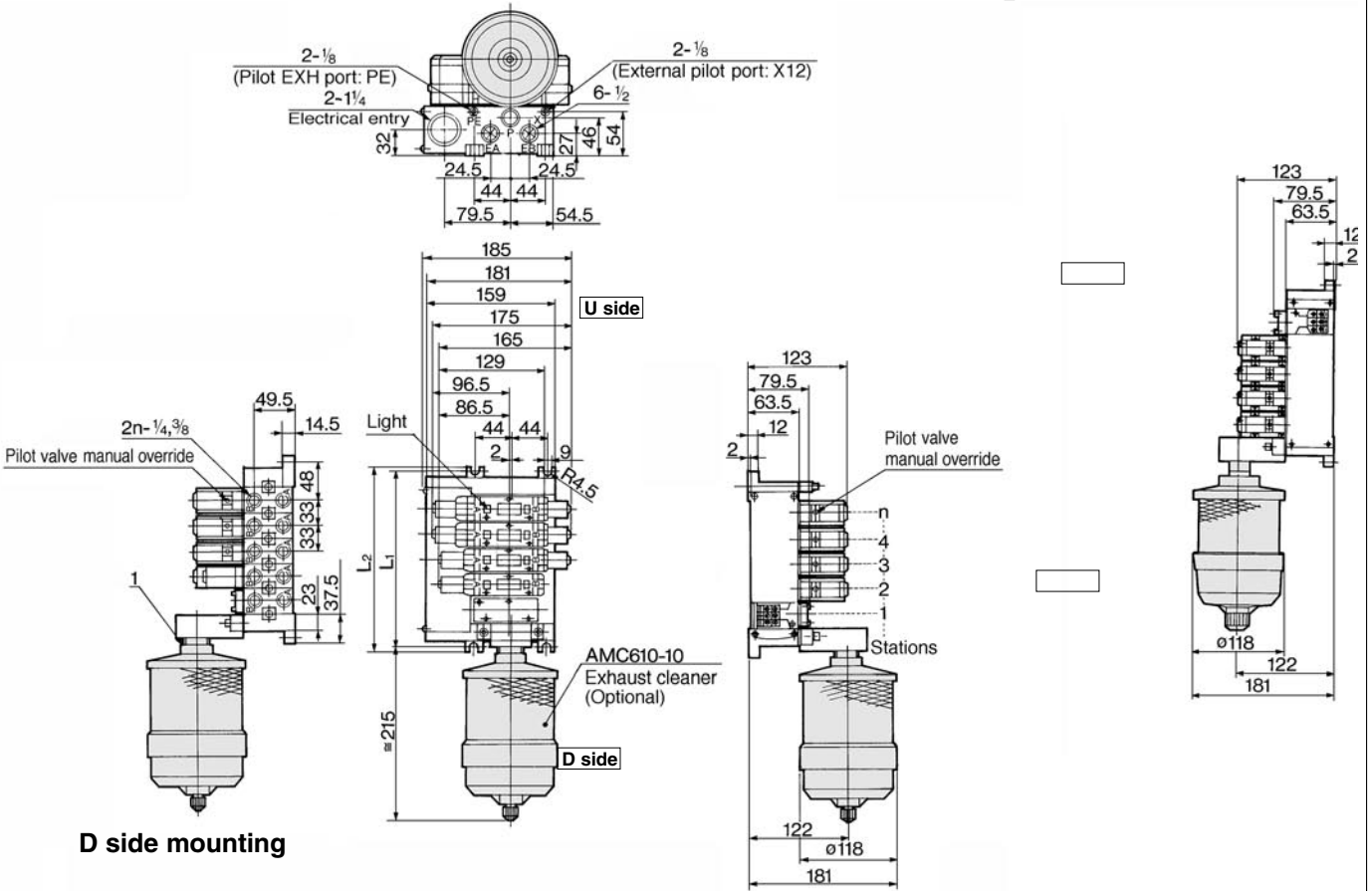

Non plug-in: VV5FS3-10- Station 1- Port size $\frac{CD}{CU}$

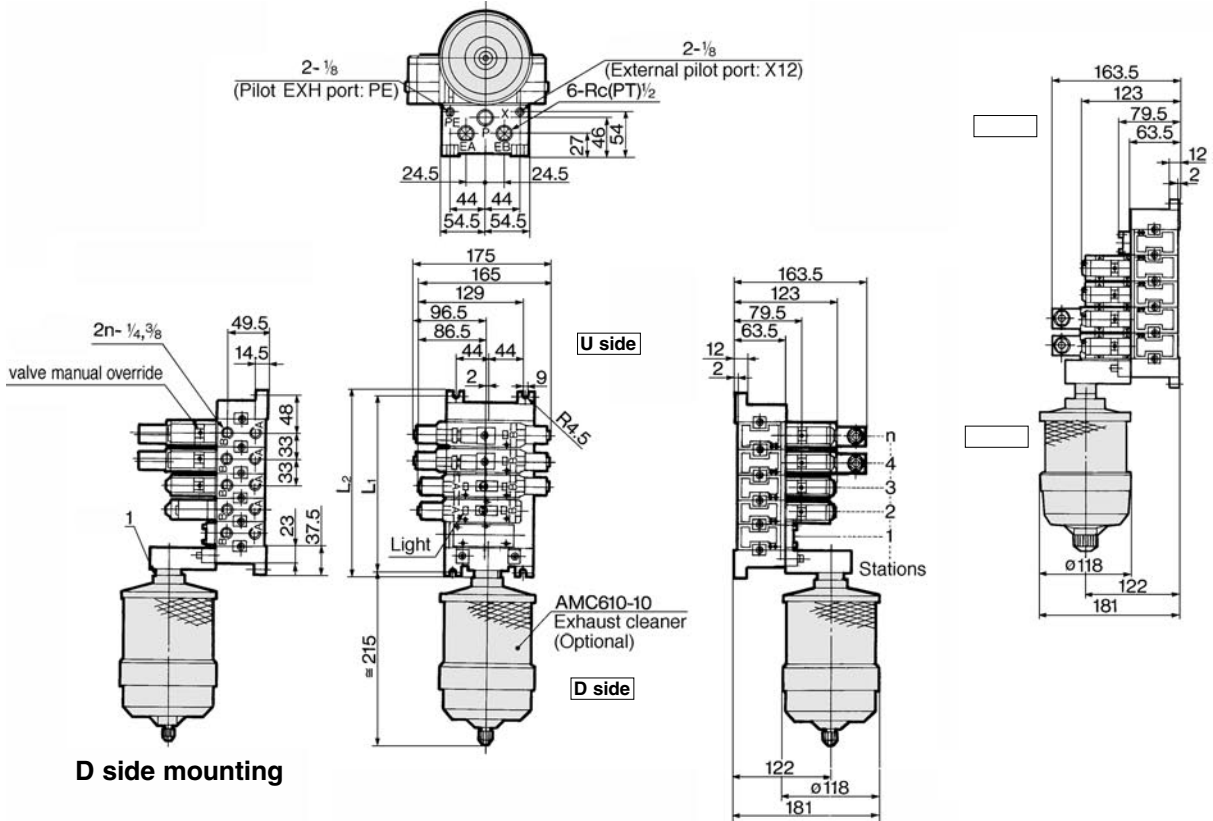

L	"	2	3	4	5	6	7	8	9	10	Calculation formula
L1		129	162	195	228	261	294	327	360	393	L1=33 X n+63
L2		141	174	207	240	273	306	339	372	405	L2=33 X n+75

Manifold with Control Unit

- Control units (Filter, Regulator, Pressure switch, Air release valve) are all standardized to the one unit, and can be mounted on the manifold base without any attachments.
- Piping processes are eliminated.

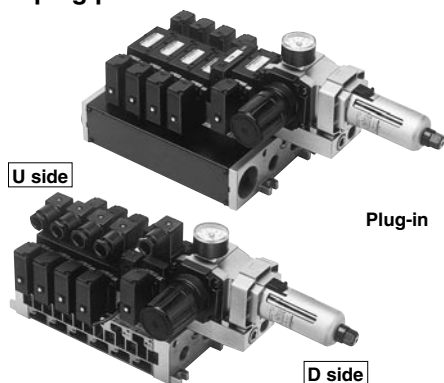

Non Plug-in

Plug-in

D side

⚠ Precautions

When using an air filter with auto drain or manual drain, mount the filter vertically.

Manifold Specifications

Manifold style	Plug-in: VV5FS3-01□	Non plug-in: VV5FS3-10
Wiring	With terminal block With multi-connector With D-sub connector	DIN connector
Applicable valve	VFS3□00-F□	VFS3□10-□D
Porting specifications	Common SUP, Common EXH	
	A, B port	1/4, 3/8
	P, EA, EB port	1/2
No. of stations	2 to 10*	

*With multi-connector, or with D-sub connector: 8 stations maximum.

Control Unit/Specifications

Air filter (With auto drain/with manual drain)	
Filtration	5 μm
Regulator	
Set press. (Secondary)	0.05 to 0.85MPa
Pressure switch ⁽¹⁾	
Set press. range: OFF	0.1 to 0.6MPa
Differential	0.08MPa or less
Contact	1a
Light	LED (Red)
Max. switch capacity	2V AC, 2W DC
Max. operating current	24V AC, DC or less: 50mA
Air release valve (Single only)	
Operating press. range	0.1 to 1.0MPa

Control Unit/Optional

Air release valve adaptor plate ⁽²⁾	<Plug-in> VVFS3000-24A-1R (D side mounting)	
	<Non plug-in> VVFS3000-24A-2R (D side mounting)	
Pressure ⁽³⁾ switch	IS1000P-2-1	
Blank plate	Filter regulator	MP2-3
	Pressure switch	MP3-2
	Air release valve	VVFS3000-24A-10
Filter element	INA-13-854-12-40B	

Note 1) Rated voltage: 24V DC to 100V AC
Inner voltage drop: 4V

Note 2) Combination of valve VFS31□□ (single) and a release valve spacer can be used an air release valve.

Note 3) Non plug-in style cannot be mounted afterwards.

How to Order

Ordering Example: VV5FS3-10-08-1-02-AP-Q

Series VFS3000 Manifold

Ordering source area code

Code	areas
-	Japan, Asia Australia
E	Europe
N	North America

Base style/Wiring

01T	Plug-in with terminal block
01C	Plug-in with multi-connector
01F	Plug-in with D-sub connector
10	Non plug-in

Connector mounting direction

Symbol	Connector mounting	Applicable base
-	None	01T, 10
D	D side	01C, 01F
U	U side	01C, 01F

Stations

02	2 stations
:	:
10	10 stations

Porting specification

Symbol	Port specification		Porting (A, B)
	P	EA, EB	
1	Common	Common	Side
2	Common	Common	Bottom*

*Option

Port size

Symbol	P, EA, EB	A, B
02		1/4
03	1/2	3/8
M		Mix

Thread

-	Rc (PT)
N	NPT
T	NPTF
F	G (PF)

Voltage for air release valve

-	Without air release valve (F, G type only)
5	24V DC
9	Other (50 or less)

Contact SMC for other voltages (9)

Control unit

Control equipment	Symbol	-	A	AP	M	MP	F	G	C	E
Air filter with auto drain			●	●			●			
Air filter with manual drain					●	●		●		
Regulator			●	●	●	●	●			
Air release valve			●	●	●	●			●	●
Pressure switch*				●		●				
Blank plate (Air release valve)							●	●		
Blank plate (Filter, regulator)									●	
Required manifold block		2 stations	2 stations	2 stations	2 stations	2 stations	2 stations	2 stations	2 stations	1 station

Please indicate manifold base mounting style, corresponding valve, and option parts.

<<Ordering example>>•Plug-in with terminal block—Requires 2 stations (Manifold base) VV5FS3-01T-081-03-AP-Q 1
(2 position single) VFS3100-5FZ-Q 4
(2 position double) VFS3200-5FZ-Q 2

<<Ordering example>>•Non plug-in—Requires 2 stations (Manifold base) VV5FS3-10-061-03-A-Q 1
(2 position single) VFS3110-5D-Q 4

VFS3000

Manifold with Control

Plug-in/Non Plug-in

Plug-in: VV5FS3-01T- Station 1- Port size -AP

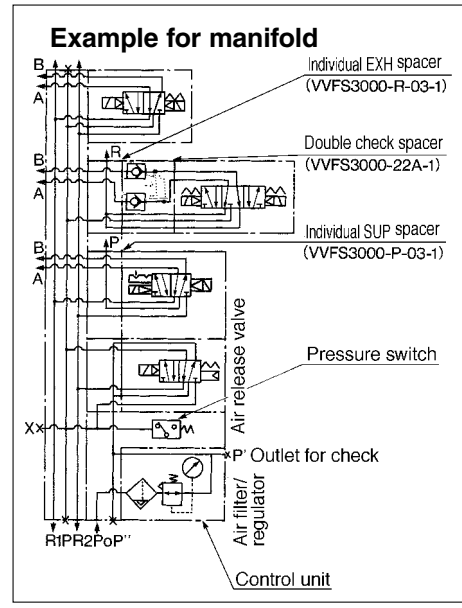
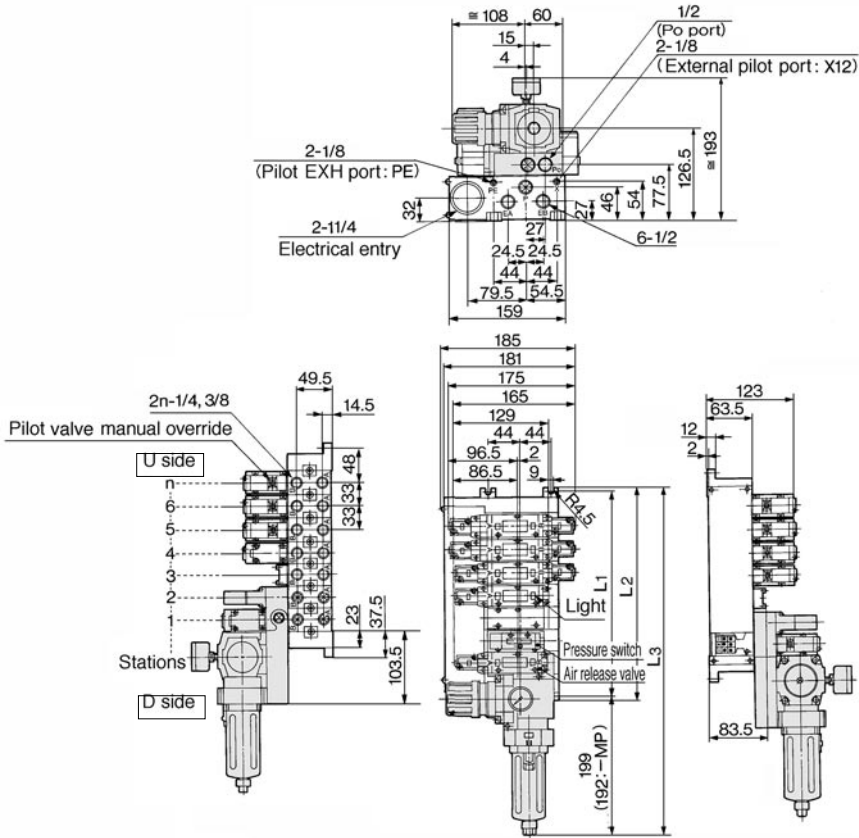

Non plug-in: VV5FS3-10- Station 1- Port size -AP

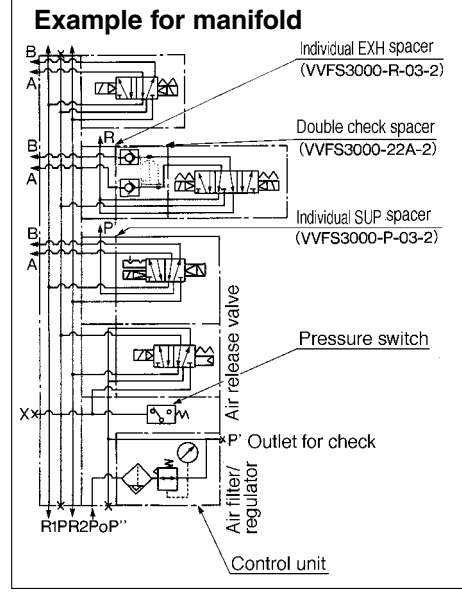
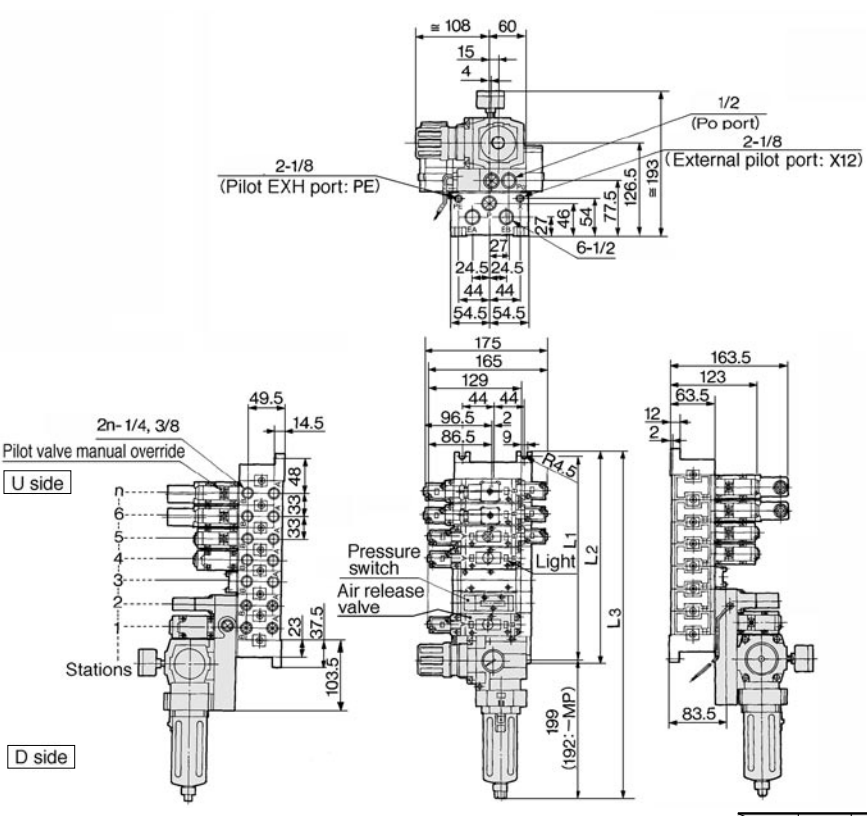

L \ n	3	4	5	6	7	8	9	10	Calculation
L1	162	195	228	261	294	327	360	393	L1=33 X n+63
L2	174	207	240	273	306	339	372	405	L2=33 X n+75
L3(MP)	358	391	424	457	490	523	556	589	L3=33 X n+259
L3(AP)	379.5	412.5	445.5	478.5	511.5	544.5	577.5	610.5	L3=33 X n+280.5

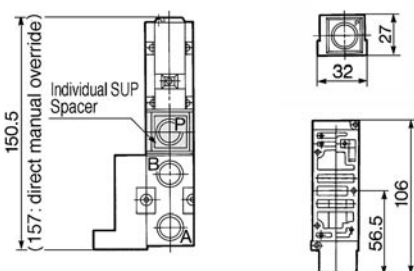
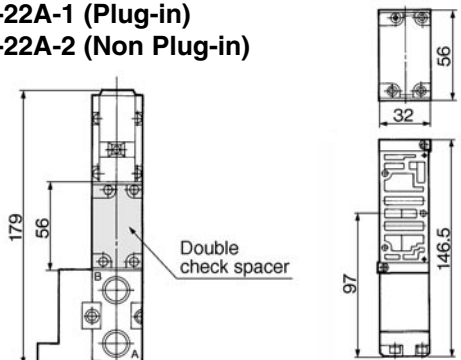
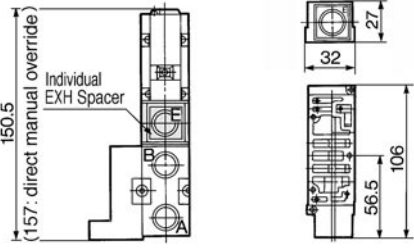
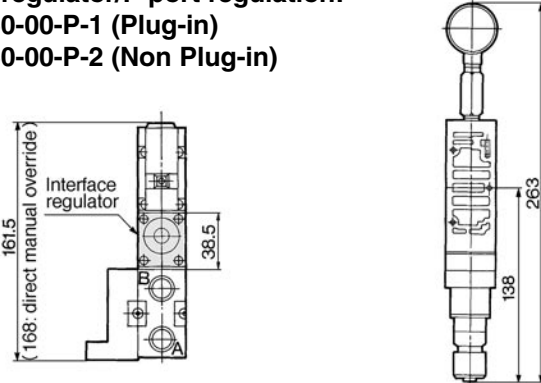
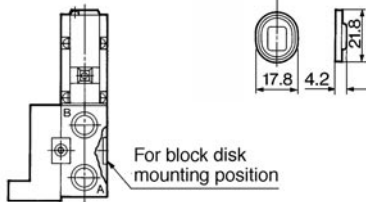
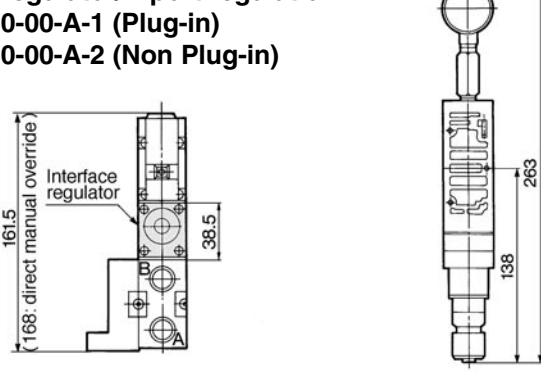
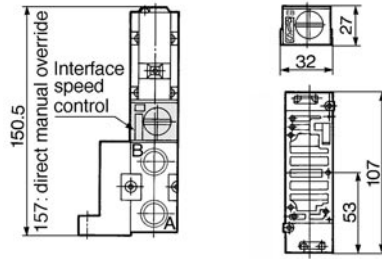
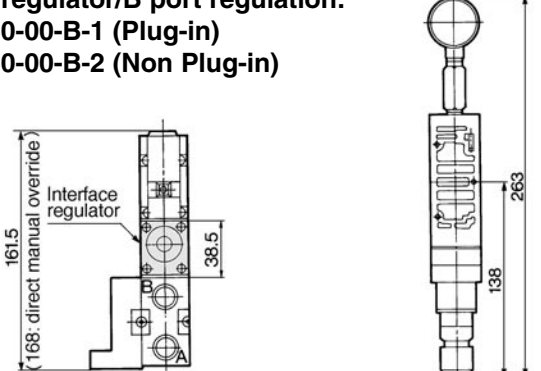
Manifold Option	Plug-in/Non Plug-in
<p>Individual SUP spacer: VVFS3000-P-03-1 (Plug-in) VVFS3000-P-03-2 (Non Plug-in)</p> 	<p>Double check spacer: VVFS3000-22A-1 (Plug-in) VVFS3000-22A-2 (Non Plug-in)</p> 
<p>Individual EXH spacer: VVFS3000-R-03-1 (Plug-in) VVFS3000-R-03-2 (Non Plug-in)</p> 	<p>Interface regulator/P port regulation: ARBF3050-00-P-1 (Plug-in) ARBF3050-00-P-2 (Non Plug-in)</p> 
<p>SUP, EXH block disk: AXT636-1A</p> 	<p>Interface regulator/A port regulation: ARBF3050-00-A-1 (Plug-in) ARBF3050-00-A-2 (Non Plug-in)</p> 
<p>Interface speed control: VVFS3000-20A-1 (Plug-in) VVFS3000-20A-2 (Non Plug-in)</p> 	<p>Interface regulator/B port regulation: ARBF3050-00-B-1 (Plug-in) ARBF3050-00-B-2 (Non Plug-in)</p> 

VFS3000

Manifold Base Construction Plug-in/Non Plug-in

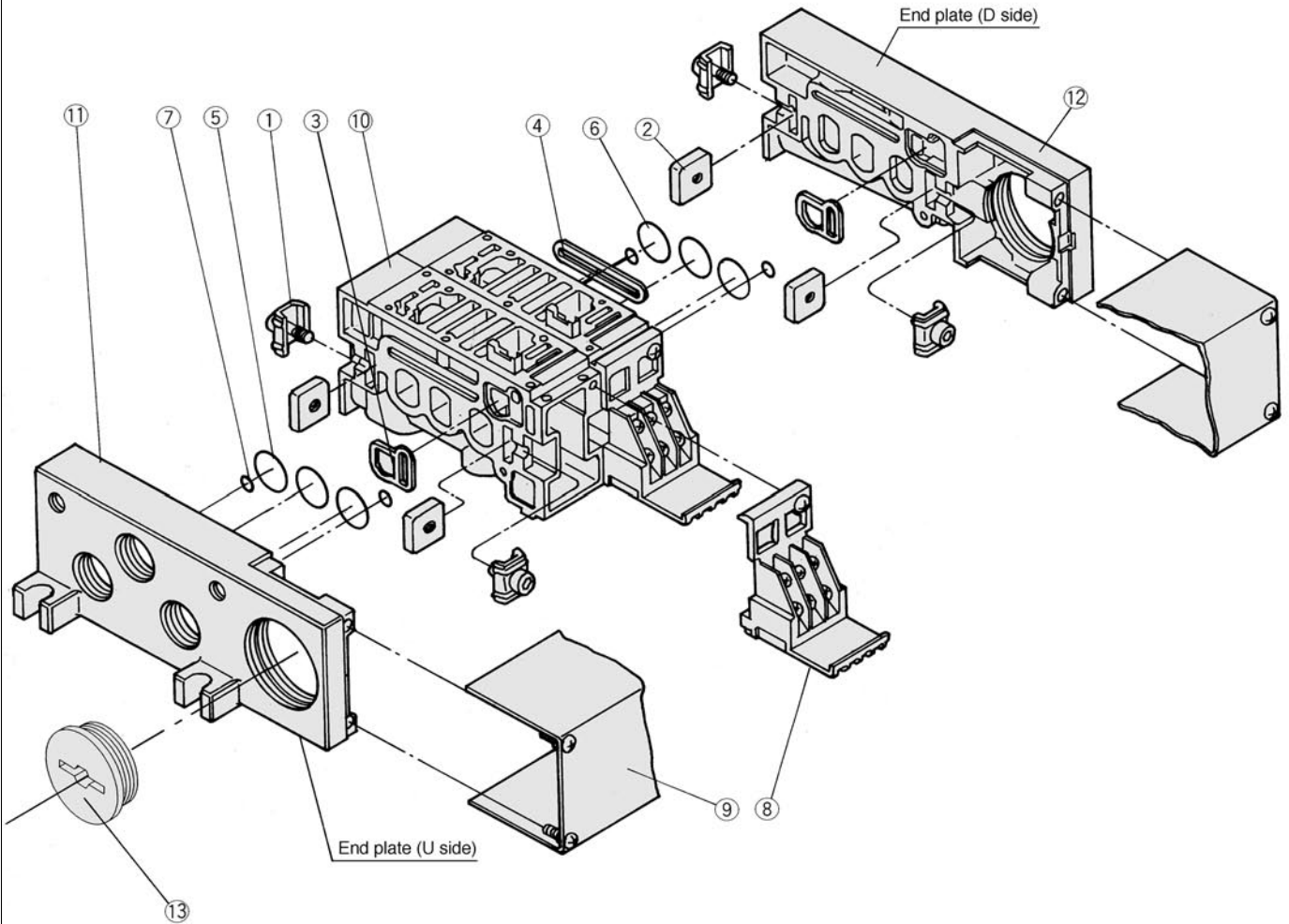

Replacement Parts

No.	Description	Material	Part No.
①	Metal joint A	Steel plate	VVFS3000-5-1A
②	Metal joint B	Steel plate	VVFS3000-5-2
③	Gasket	NBR	VVFS3000-7
④	Gasket	NBR	VVFS3000-8
⑤	O ring	NBR	19.8 X 16.6 X 1.6 (End plate)
⑥	O ring	NBR	20 X 16 X 2 (Manifold block)
⑦	O ring	NBR	6.2 X 3 X 1.6
⑧	Terminal assembly		VVFS3000-6A
⑨	Junction cover assembly	For 01T For 01SU	VVFS3000-4A-[stations] AZ738-22A-[stations]
⑬	Rubber plug	NBR	AXT336-9

•For increasing the manifold bases, please order the manifold block assembly number of the principal part assembly 9. For plug-in: The manifold base with terminal stand (integrated with a junction cover) is required with the 8 junction cover assembly.

Replacement Parts Sub-assembly



Note) Manifold Base/Construction: Plug-in with terminal block.

No.	Description	Assembly part No.	Component parts	Applicable manifold base
⑩	Manifold block assembly	VVFS3000-1A-1- ⁰² / ₀₃	Manifold block ⑩, Terminal ⑧, Metal joint ①, ②, Gasket ③, ④, O ring ⑥, ⑦, Receptacle assembly	Plug-in
		VVFS3000-1A-2- ⁰² / ₀₃	Manifold block ⑩, Metal joint ①, ②, Gasket ③, ④, O ring ⑥, ⑦	Non plug-in
⑪	End plate (U side) assembly	VVFS3000-2A-1	End plate (U) ⑪, Metal joint ①, ②, O ring ⑤, ⑥	Plug-in
		VVFS3000-2A-2	End plate (U) ⑪, Metal joint ①, ②, O ring ⑤, ⑥	Non plug-in
⑫	End plate (D side) assembly	VVFS3000-3A-1	End plate (D) ⑫, Metal joint ①, ②, Gasket ③	Plug-in
		VVFS3000-3A-2	End plate (D) ⑫, Metal joint ①, ②, Gasket ③	Non plug-in

5 Port Pilot/Metal Seal

Plug-in/Non Plug-in

Series VFS4000

Compact despite large flow capacity 1/2: N/min 3533

Small Power Consumption/1.8W DC

Easy to maintain

2 styles of sub-plates: plug-in and non plug-

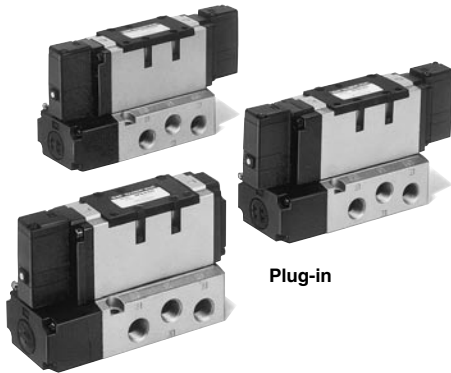

Plug-in

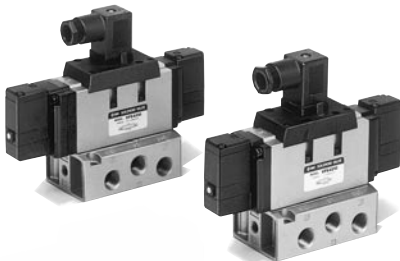

Non Plug-in

JIS Symbol

2 position	3 position
Single	Closed centre
Double	Exhaust centre
	Pressure centre
	Double check

Model

Configuration	Model		Port size	Effective area (mm ²) (N/min)	Max. operating cycle (CPM) (1)	Response time (ms) (2)	Weight (kg) (3)	
	Plug-in	Non Plug-in						
2 position	Single	VFS4100	VFS4110	3/8	59.4 (3239)	1,000	40 or less	0.63
				1/2	64.8 (3533)			
	Double	VFS4200	VFS4210	3/8	59.4 (3239)	1,200	15 or less	0.75
				1/2	64.8 (3533)			
3 position	Closed centre	VFS4300	VFS4310	3/8	50.4 (2748)	600	50 or less	0.82
				1/2	54.0 (2945)			
	Exhaust centre	VFS4400	VFS4410	3/8	50.4 (2748)	600	50 or less	0.82
				1/2	54.0 (2945)			
	Pressure centre	VFS4500	VFS4510	3/8	57.6 (3141)	600	50 or less	0.82
				1/2	61.2 (3337)			
	Double check	VFS4600	VFS4610	3/8	30.2 (1669)	200	55 or less	1.71
				1/2	32.4 (1767)			

- Note 1) According to JIS B8375 (Once per 30 days) for the minimum operating frequency.
 Note 2) According to JIS B8375-1981 (The value at supply press. 0.5MPa).
 Note 3) The figures in the above list are for without subplate. In the case of with plug-in sub-plate and with non plug-in sub-plate, add 0.50 kgf and 0.43 kgf respectively.
 Note 4) "Note 1)" and "Note 2)" are with controlled clean air.

Standard Specifications

	Fluid	Air and inert gas	
Valve	Max. operating pressure	1.0MPa	
	Min. operating pressure	2 position: 0.1MPa 3 position: 0.15MPa	
	Proof pressure	1.5MPa	
	Ambient and fluid temperature	-10 to +60°C (1)	
	Lubrication	Not required (1)	
	Pilot valve manual override	Non-locking push style (Flush)	
	Shock/vibration resistance	150/50m/s ² (3)	
	Protection structure	E: Dust proof (class 0), E: Drip proof (class 2), D: Splash proof (class 4) (4)	
	Electricity	Rated voltage	100V, 200V AC 50/60Hz, 24V DC
		Allowable voltage	-15 to +10% rated voltage
Coil insulation		Class B or equivalent (130°) (5)	
Apparent power (Power consumption) AC		Inrush: 5.6VA/50Hz, 5.0VA/60Hz Holding: 3.4VA (2.1W)/50Hz, 2.3VA (1.5W)/60Hz	
Power consumption DC		1.8W	
Electrical entry		Plug-in: Conduit terminal Non plug-in: DIN connector	

- Note 1) Use dry-air at low temperatures.
 Note 2) Use turbine oil No.1 (ISO VG32), if lubricated.
 Note 3) Shock resistance: No malfunction from test using drop impact tester to axis and right angle directions of main valve and armature, each one time when energized and de-energized. (Value in the initial stage.)
 Vibration resistance: No malfunction from test with 8.3 to 2000Hz 1 sweep, to axis and right angle directions of main valve and armature, each one when energized and de-energized. (Value in the initial stage.)
 Note 4) According to JIS C0920. Note 5) According to JIS C4003.

Option Specifications

Pilot style		External pilot (1)
Manual override	Main valve	Direct manual override
	Pilot valve	
Voltage		110 to 120V, 220V, 240V AC 50/60Hz
Porting		12V, 100V DC
Option		Bottom porting
With indicator light and surge voltage suppressor, Non-rotating DIN connector		

- Note 1) Operating pressure: 0 to 1.0MPa
 Pilot pressure ————— 2 position: 0.1 to 1.0MPa 3 position: 0.15 to 1.0MPa

VFS4000

How to Order

Ordering source area code

Code	areas
-	Japan, Asia Australia
E	Europe
N	North America

Body

O: Plug-in sub-plate

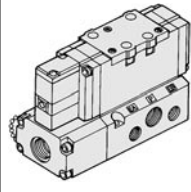

Electrical entry

F: Plug-in conduit terminal

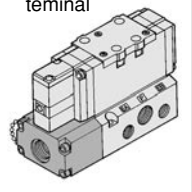

Porting

-	Side
B*	Bottom

*Option

*Option
In an external pilot specification, bottom porting is impossible.

Port size

-	Without sub-plate
03	3/8
04	1/2

*EA, EB: 3/8

Thread

-	Rc (PT)
N	NPT
T	NPTF
F	G (PF)



Plug-in

VFS4 2 0 0 5 F 03 - Q

Non plug-in

VFS4 2 1 0 1 D 03 - Q

Configuration

1	2 position single 	5	3 position pressure centre
2	2 position double 	6	3 position double check
3	3 position closed centre 		
4	3 position exhaust centre 		



*For reverse pressure, it is applicable in external pilot specification.

Body

1: Non plug-in sub-plate

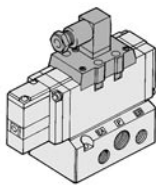

Body option

0	Standard
1*	Direct manual override

*Option

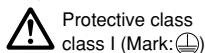

Protective class class I (Mark: ⊕)

Indicator light/surge voltage suppressor

-	None
Z	With indicator light and surge voltage suppressor

Electrical entry

D: DIN connector
DO: Without connector

Y: DIN connector (DIN 43650)
YO: Without DIN connector

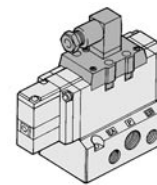
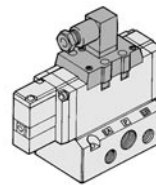

Voltage

1	100V AC (50/60Hz)
2	200V AC (50/60Hz)
3	110V to 120V AC (50/60Hz)
4	220V AC (50/60Hz)
5	24V DC
6	12V DC
7	240V AC (50/60Hz)
9	Other (250 or less)



Contact SMC for other voltages (9)

Pilot

-	Internal
R*	External

*Option

Pilot valve manual override

-: Non-locking push style (Flush)

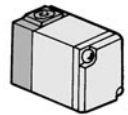

A*: Non-locking push style (Extended)

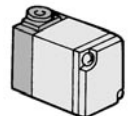

B*: Locking style (Slotted)

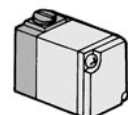

C*: Locking style (Lever)

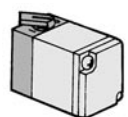

*Option

How to Order Pilot Valve Assembly

SF4 - 1 F - 30 - Q

Voltage

1	100V AC (50/60Hz)
2	200V AC (50/60Hz)
3	110V to 120V AC (50/60Hz)
4	220V AC (50/60Hz)
5	24V DC
6	12V DC
7	240V AC (50/60Hz)
9	Other (250 or less)

Manual override

-	Non-locking push style (Flush)
A*	Non-locking push style (Extended)
B*	Locking style (Slotted)
C*	Locking style (Lever)

*Option



Contact SMC for other voltages (9)



*Refer to p.1.17-5 for voltage conversion.

Maximum Cylinder Speed

System diagram

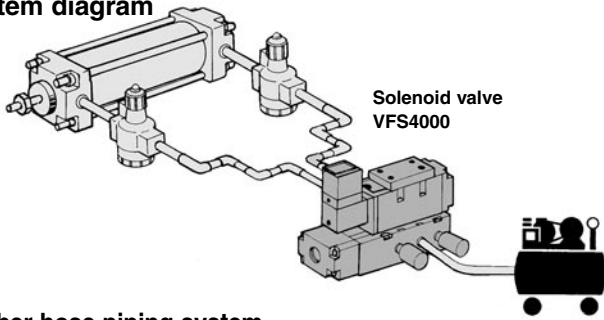

Rubber hose piping system

Conditions: Supply pressure 0.5MPa, Load factor 50%

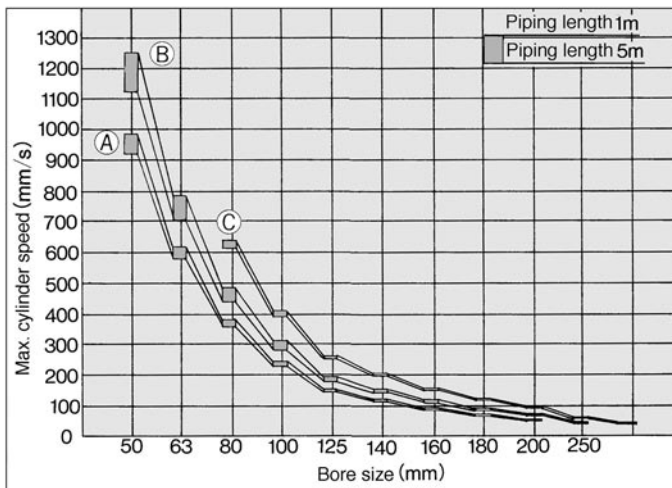

System	Solenoid valve	Speed controller	Silencer	Piping
A	VFS4000-03 (3/8) (S=59.4mm ²)	AS4000-03 (S=21mm ²)	AN300-03 (S=60mm ²)	3/8 Rubber hose (Fittings 4 pcs.)
B	VFS4000-03 (3/8) (S=59.4mm ²)	AS420-03 (S=73mm ²)	AN300-03 (S=60mm ²)	3/8 Rubber hose (Fittings 4 pcs.)
C	VFS4000-04 (1/2) (S=65mm ²)	AS420-04 (S=97mm ²)	AN300-03 (S=60mm ²)	1/2 Rubber hose (Fittings 4 pcs.)

S. G. P. piping system

Conditions: Supply pressure 0.5MPa, Load factor 50%

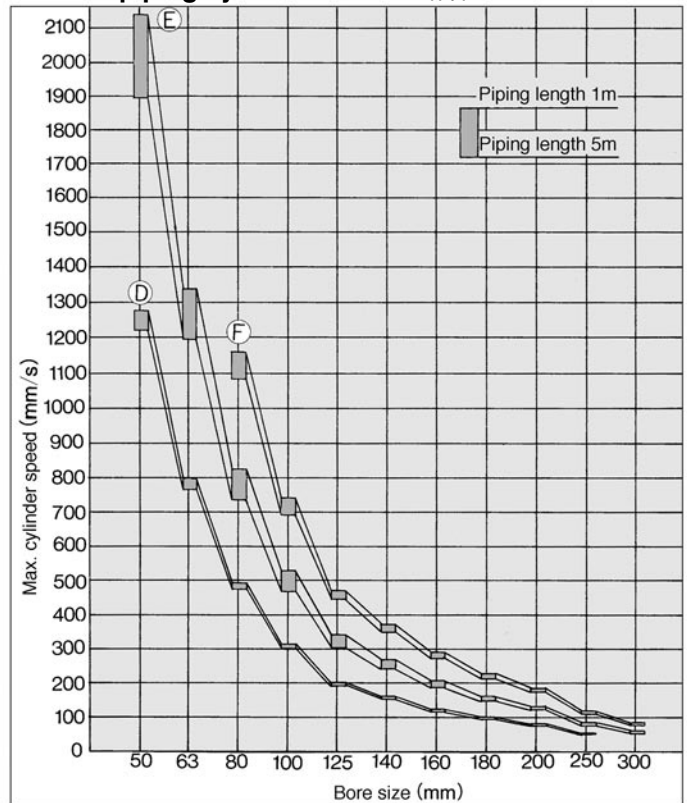

System	Solenoid valve	Speed controller	Silencer	Piping
D	VFS4000-03 (3/8) (S=59.4mm ²)	AS4000-03 (S=21mm ²)	AN300-03 (S=60mm ²)	3/8 ^B , SGP (Elbow 4 pcs.)
E	VFS4000-03 (3/8) (S=59.4mm ²)	AS420-03 (S=73mm ²)	AN300-03 (S=60mm ²)	3/8 ^B , SGP (Elbow 4 pcs.)
F	VFS4000-04 (1/2) (S=65mm ²)	AS420-04 (S=97mm ²)	AN300-03 (S=60mm ²)	1/2 ^B , SGP (Elbow 4 pcs.)

Double Check Spacer/Specification

Holding cylinder mid-position for a long periods

The concurrent use of double check spacer with built-in double check valve can stop cylinder or mid-position and hold it without being affected by air leakage spool seals.

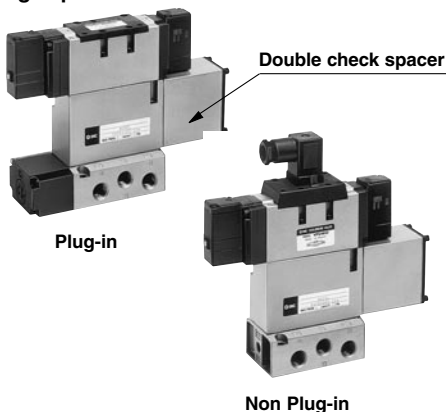

Specifications

Double check spacer	Plug-in		Non plug-in	
	VVFS4000-22A-1		VVFS4000-22A-2	
Applicable solenoid valve	VFS4400-□F		VFS4410-□D VFS4410-□E	
Leakage* (cm ³ / min)	Solenoid one side energized	P	EA	230 or less
			EB	
	Solenoid both sides de-energized	P	EA	230 or less
			EB	
	A	EA	0	
	B	EB		

Supply pressure: 0.5MPa

⚠ Precautions

- In the case of 3 position double check valve (VFS46□0), check the leakage from piping and fittings in between valve and cylinder by means of synthetic detergent solutions, and ensure that there is no such leakage found there. Also check the leakage from cylinder seal and piston seal. If there is any leakage, sometimes the cylinder, when valve is de-energized, can move without stopping at mid-position.
- Be aware that if the exhaust side is restricted excessively, the intermediate stopping accuracy will decrease and will lead to improper intermediate stops.

Check Valve Operation

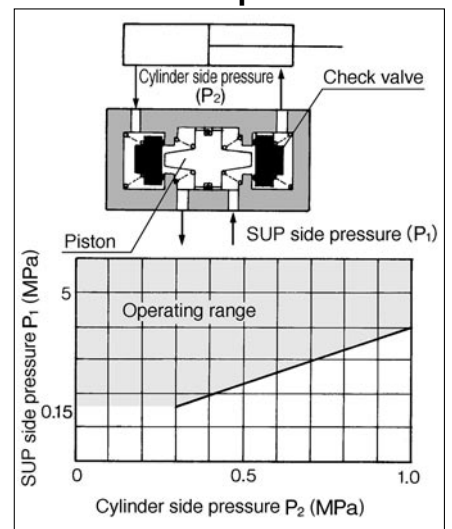

- The combination of VFS4□0, VFS42□0 and a double check spacer can be used as prevention of falling at the stroke end but cannot hold the intermediate position of the cylinder.

VFS4000

Construction

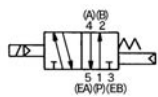

2 position single

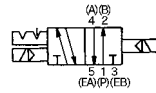

2 position dou-

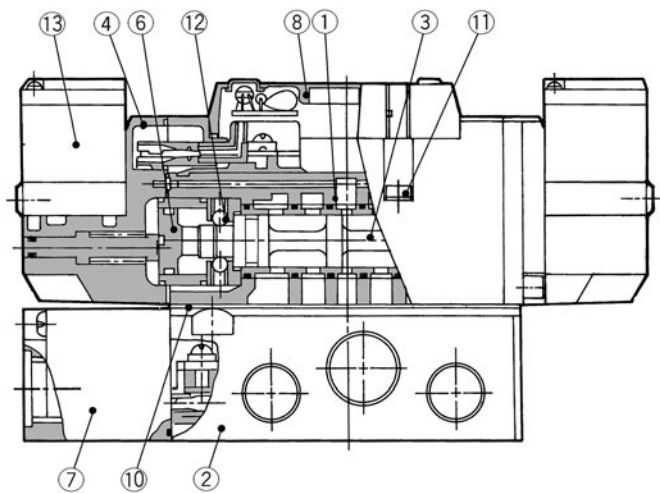
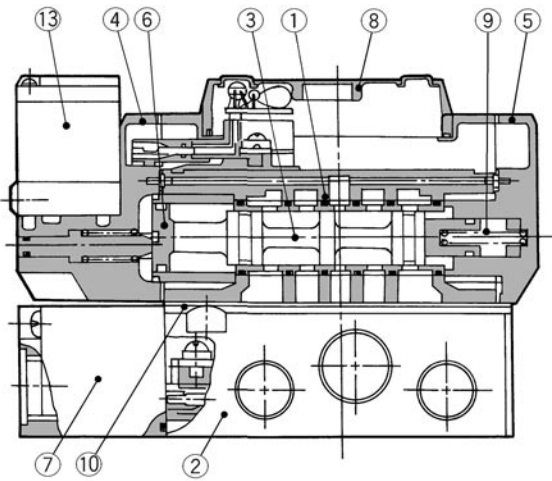

3 position closed centre/exhaust centre/pressure centre

Closed centre

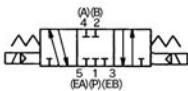

Exhaust centre



Pressure centre

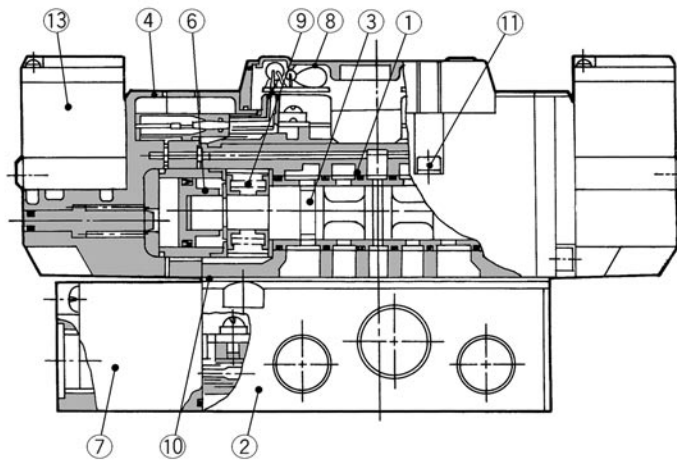

Component Parts

No.	Description	Material	Note
①	Body	Aluminium die cast	Platinum silver
②	Sub plate	Aluminium die cast	Platinum silver
③	Spool/Sleeve	Stainless steel	
④	Adaptor plate	Aluminium die cast	Black
⑤	End plate	Aluminium die cast	Black
⑥	Piston	Resin	
⑦	Junction cover	Resin	
⑧	Light cover	Resin	

Sub-plate Assembly

Plug-in	VFS4000-P- ⁰³ / ₀₄
Non plug-in	VFS4000-S- ⁰³ / ₀₄



*Without mounting screw and gasket.

Replacement Parts

No.	Description	Material	Part No.		
			VFS41□□	VFS42□□	VFS43□□, 44□□, 45□□
⑨	Return spring	Stainless steel	VF4000-18-1	—	VF4000-18-2A
⑩	Gasket	NBR	VF4000-20-1	VF4000-20-1	VF4000-20-1
⑪	Hexagonal socket head cap screw	Steel	M4 X 40	M4 X 40	M4 X 40
⑫	Detent assembly	—	—	VF4000-12A	—
⑬	Pilot valve assembly	—	—	—	—

Refer to "How to order Pilot valve assembly" on p.1.17-70.

Plug-in 2 Position Single/Double, 3 Position Closed Centre/Exhaust Centre/Pressure Centre/Double

2 position single: VFS4100-□F

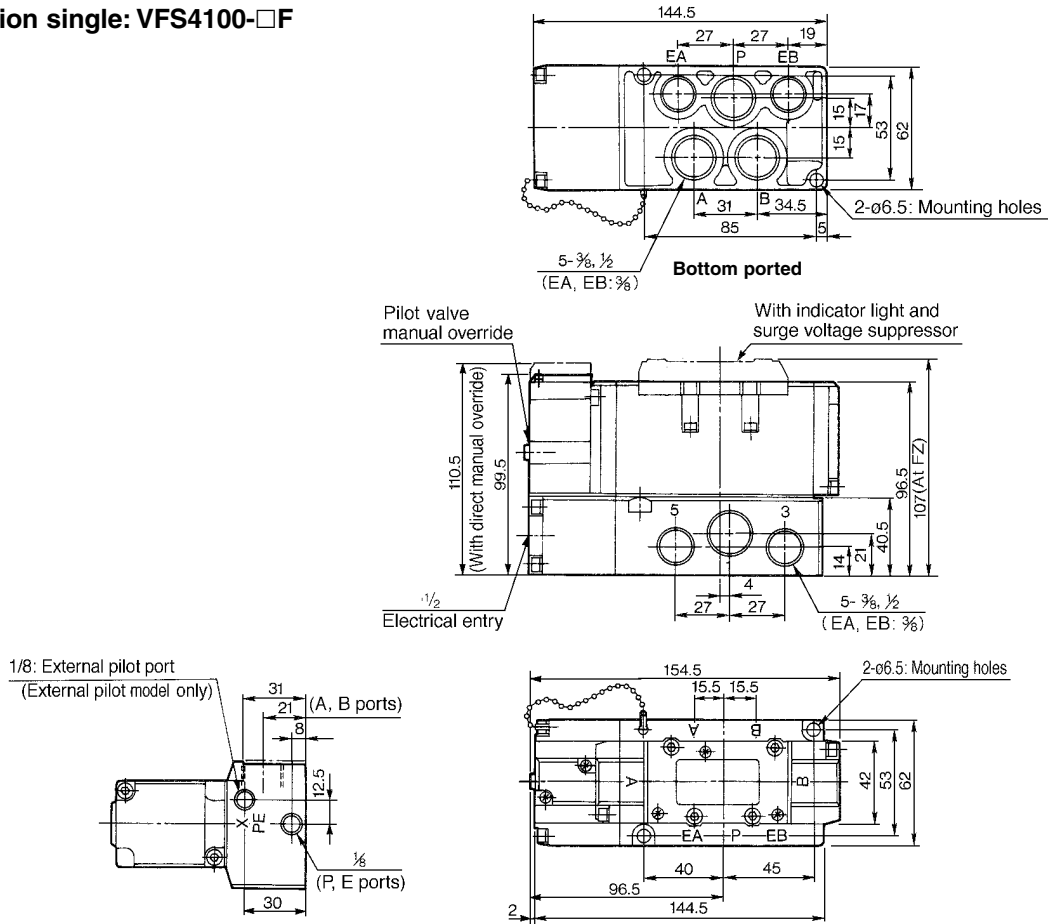

2 position double: VFS4200-□F

3 position closed centre: VFS4300-□F

3 position exhaust centre: VFS4400-□F

3 position pressure centre: VFS4500-□F

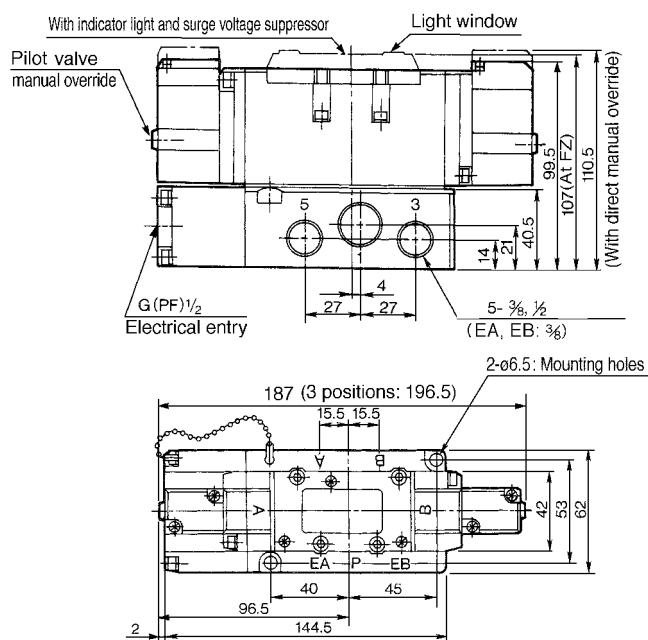

3 position double check: VFS4600-□F

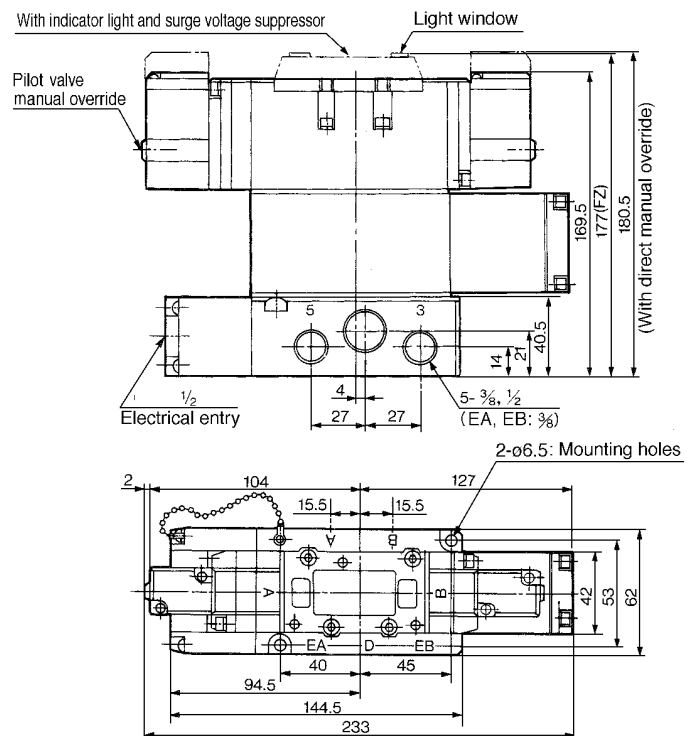

VFS4000

Non Plug- 2 Position Single/Double, 3 Position Closed Centre/Exhaust Centre/Pressure Centre/Double

2 position single: VFS4110-□D

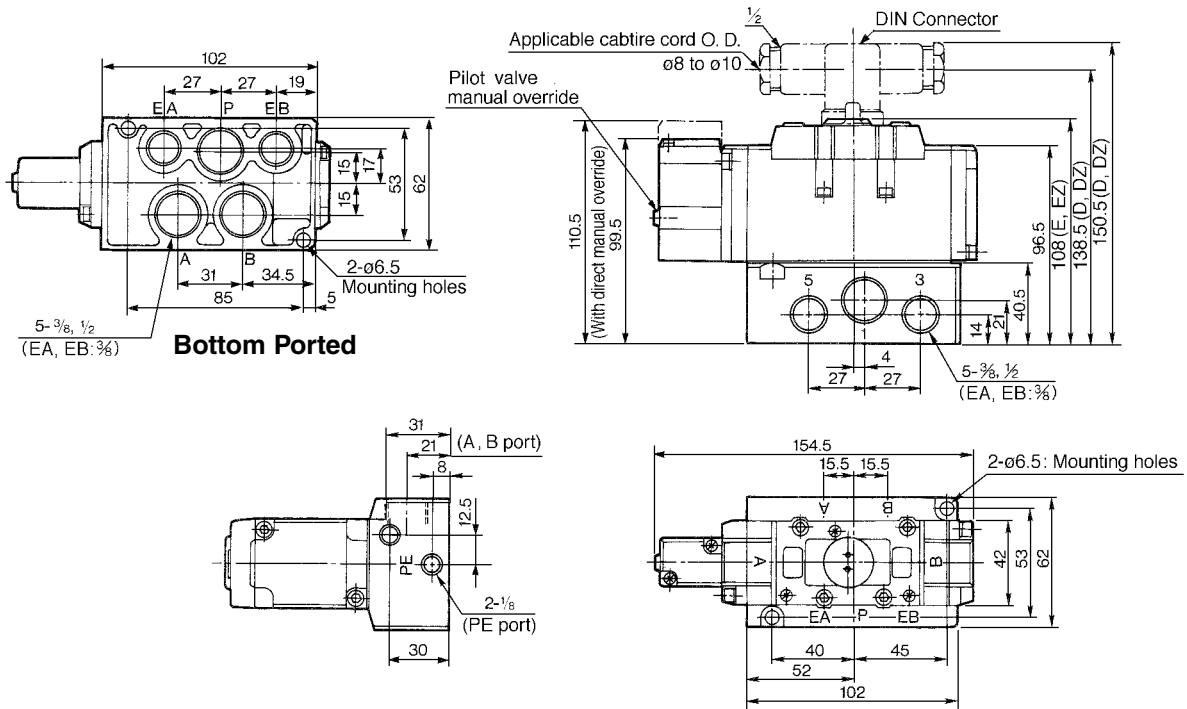

2 position double: VFS4200-□D

3 position closed centre: VFS4310-□D

3 position exhaust centre: VFS4410-□D

3 position pressure centre: VFS4510-□D

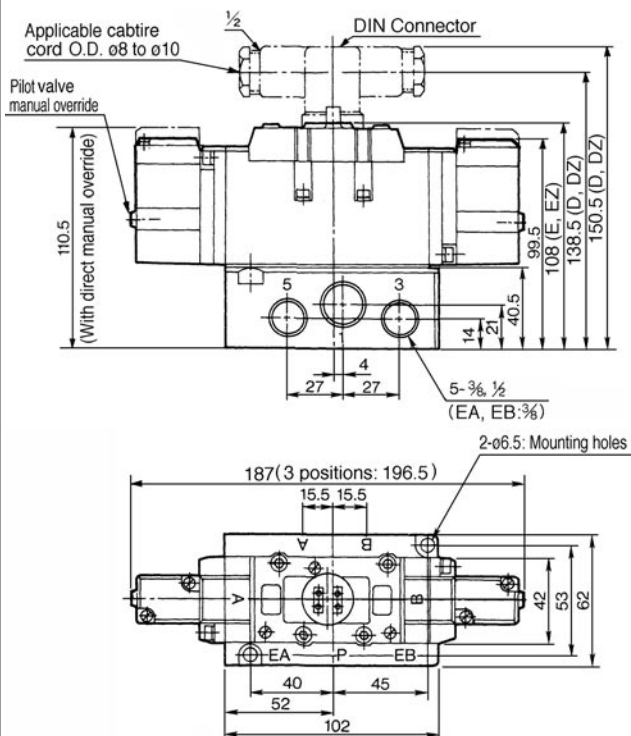

3 position double check: VFS4610-□D

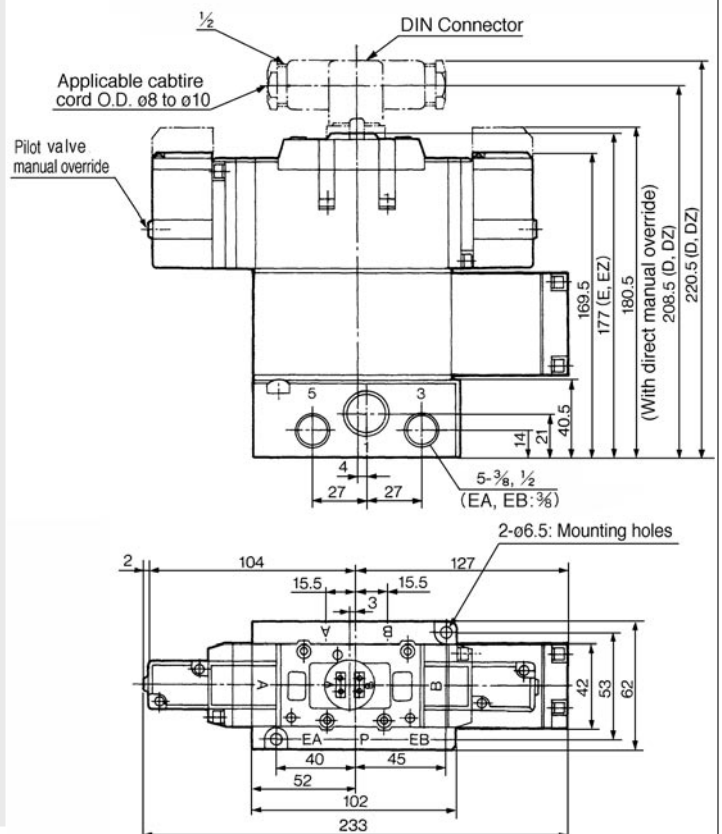

Series VFS4000 Manifold

Plug-in: With Terminal Block

- Since lead wires of solenoid valve are connected with the terminals on upper surface of terminal block, corresponding lead wires from power source can be wired at the bottom of terminal block.

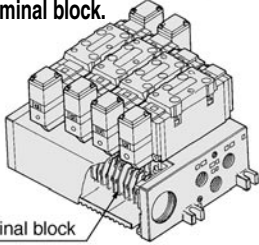

Terminal block

VV5FS4 - 01T - 06 1 - 03 - Q

Series VFS4000 Manifold Plug-in with terminal block

Stations

02	2 stations
:	:
10	10 stations

Port size

Symbol	P, EA, EB	A, B
03		3/8
04	1/2	1/2
M		Mix

Thread

	Rc (PT)
N	NPT
T	NPTF
F	G (PF)

Ordering source area code

Code	areas
-	Japan, Asia Australia
E	Europe
N	North America

Symbol

Symbol	Port specifications	Porting (A, B)
1	Common	Common
2	Common	Bottom*

*Option

*Bottom ported: Only 3/8.

Plug-in: With Multi-connector

(Wiring specifications *Please refer to p.1.17-8.)

- Master connection of power and solenoid valves.
- Quick wiring permits easier installation.

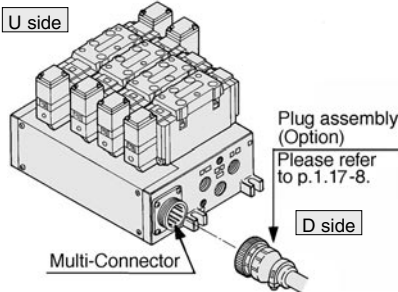

VV5FS4 - 01C D - 05 2 - 03 - Q

Series VFS4000 Manifold Plug-in with multi-connector

Stations

02	2 stations
:	:
08*	8 stations

*Max: 8 stations.

Port size

Symbol	P, EA, EB	A, B
03		3/8
04	1/2	1/2
M		Mix

Thread

	Rc (PT)
N	NPT
T	NPTF
F	G (PF)

Ordering source area code

Code	areas
-	Japan, Asia Australia
E	Europe
N	North America

Mounting direction of connector

D	D side mounting
U	U side mounting

Symbol

Symbol	Port specifications	Porting (A, B)
1	Common	Common
2	Common	Bottom*

*Option

*Bottom ported: Only 3/8.

Plug-in: With D-sub Connector

(Wiring specifications *Please refer to p.1.17-

- Wide range of interchangeability (MIL Spec DIN connector terminal 25 pcs attached.)
- Quick wiring permits easier installation.

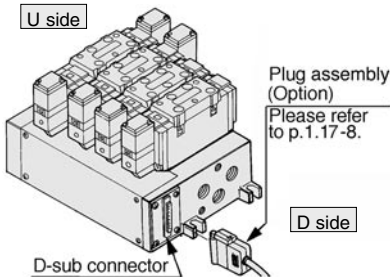

VV5FS4 - 01F D - 06 1 - 03 - Q

Series VFS4000 Manifold Plug-in with D-sub connector

Stations

02	2 stations
:	:
08*	8 stations

*Max: 8 stations.

Port size

Symbol	P, EA, EB	A, B
03		3/8
04	1/2	1/2
M		Mix

Thread

	Rc (PT)
N	NPT
T	NPTF
F	G (PF)

Ordering source area code

Code	areas
-	Japan, Asia Australia
E	Europe
N	North America

Mounting direction of connector

D	D side mounting
U	U side mounting

Symbol

Symbol	Port specifications	Porting (A, B)
1	Common	Common
2	Common	Bottom*

*Option

*Bottom ported: Only 3/8.

Non Plug-in: DIN Connector

- Wiring for every valve.

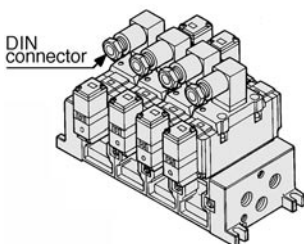

VV5FS4 - 10 - 05 2 - 03 - Q

Series VFS4000 Manifold Non Plug-in

Stations

02	2 stations
:	:
10	10 stations

Port size

Symbol	P, EA, EB	A, B
03		3/8
04	1/2	1/2
M		Mix

Thread

	Rc (PT)
N	NPT
T	NPTF
F	G (PF)

Ordering source area code

Code	areas
-	Japan, Asia Australia
E	Europe
N	North America

Symbol

Symbol	Port specifications	Porting (A, B)
1	Common	Common
2	Common	Bottom*

*Option

*Bottom ported: Only 3/8.

VFS4000

Manifold Specifications

Base style	Wiring	Porting	Port size		No. of stations	Applicable solenoid valve
		A, B port	P, EA, EB	A, B		
Plug-in VV5FS4-01□	<ul style="list-style-type: none"> •With terminal block •With multi-connector •With D-sub connector 	Side, Bottom	1/2	3/8, 1/2	2-10 *	VFS4□00-□F
Non plug-in VV5FS4-10	•DIN Connector					VFS4□10-□D



* With multi-connector, or with D-sub connector: 8 stations max.

Manifold Stations and Effective Area (mm²) (N/min Factor)

Porting/No. of stations	First station	Fifth station	Tenth station
P → A or B	50.4 (2748)	48.6 (2650)	47.7 (2257)
A → EA, B → EB	57.6 (3140)	55.8 (3043)	55.8 (3043)



* Port size: 1/2

Manifold/Option Parts Assembly

Individual SUP spacer

An individual SUP spacer set on manifold block can form SUP port for every valve.

Body	Plug-in	Non plug-in
Part No.	VVFS4000-P-03-1	VVFS4000-P-03-2

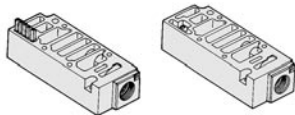

Individual EXH spacer

An individual EXH spacer set on manifold block can form EXH port for every valve.

Body	Plug-in	Non plug-in
Part No.	VVFS4000-R-04-1	VVFS4000-R-04-2

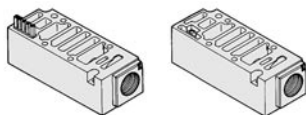

* SUP block disk

When supplying manifold with more than two different pressures, high and low, insert a block plate in between stations subjected to different pressures.

Body	Plug-in	Non plug-in
Part No.	AXT634-10A	

* EXH block disk

When valve exhaust affects the other stations on the circuit or when the reverse pressure valve is used to standard manifold valve, insert EXH block plate in between stations to separate valve exhaust.

Body	Plug-in	Non plug-in
Part No.	AXT634-11A	



EXH block disk

SUP block disk

Interface speed control

Needle valve set on the manifold block can control cylinder speed by throttling exhaust.

Body	Plug-in	Non plug-in
Part No.	VVFS4000-20A-1	VVFS4000-20A-2

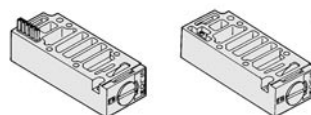

Double check spacer

The concurrent use of double check spacer with built-in double check valve can stop the cylinder at mid-position and hold for a long time without being affected by the air leakage across spool seals.

Body	Plug-in	Non plug-in
Part No.	VVFS4000-22A-1	VVFS4000-22A-2

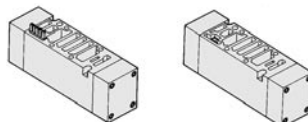

Interface regulator

Interface regulator set on manifold block can regulate the pressure to each valve. (Refer to p.1.17-6 for flow characteristic).

Body	Plug-in	Non plug-in
P regulation	ARBF4050-00-P-1	ARBF4050-00-P-2
A regulation	ARBF4050-00-A-1	ARBF4050-00-A-2
B regulation	ARBF4050-00-B-1	ARBF4050-00-B-2

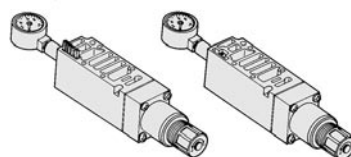

Blank plate

When disassembling valve for maintenance purposes or when spare manifold stations are required, install a blank plate on the manifold block.

Body	Plug-in	Non plug-in
Part No.	VVFS4000-10A	

How to Order Manifold

Please indicate manifold base mounting style, corresponding valve, and option parts.

- Plug-in with terminal block - 6 stations
(Manifold base) VV5FS4-01T-061-03-Q 1
(2 position single) VFS4100-5FZ -Q 3
(2 position double) VFS4200-5FZ -Q 2
(Blanking plate) VFS4000-10A 1

- Non plug-in - 6 stations
(Manifold base) VV5FS4-10-061-04-Q 1
(2 position single) VFS4110-5D-Q 5
(3 position exhaust center) VFS4110-5D-Q · 1
(Individual EXH spacer) VVFS4000-R-04-2 1

Manifold Options

With exhaust cleaner

Plug-in/Non plug-in

- Valve exhaust noise dampening: 35dB or more.
- Oil mist collection: Rate of collection 99.9% or more.
- Piping hours reduced.

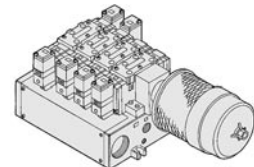

For more information, please refer to p.1.17-79.

With control unit

Plug-in/Non plug-in

- Filter, regulation valve, pressure switch and air release valve are all combined to form one unit.
- Piping work eliminated.

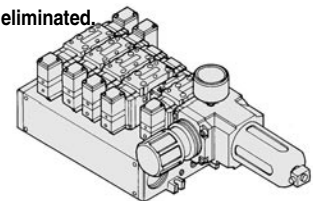

For more information, please refer to p.1.17-81.

With serial interface unit plug-in

- Solenoid valve wiring process reduced considerably.
- Disperse installation possible.
- Manifold solenoid valve: 8 stations max, 32 positions (512 solenoids).
- Maintenance and inspection are easy.

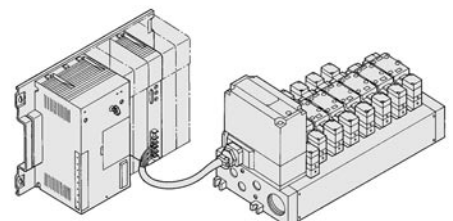

Plug-in/Non Plug-in

Plug-in (With terminal block): VV5FS4-01T- Station 1- Port size

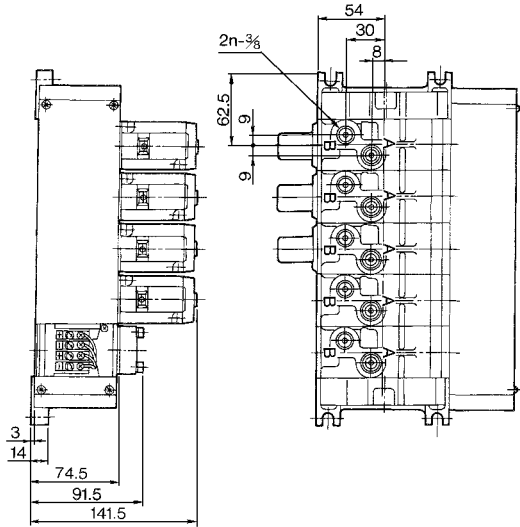

Bottom ported:
VV5FS4-01T- Station 2- Port size

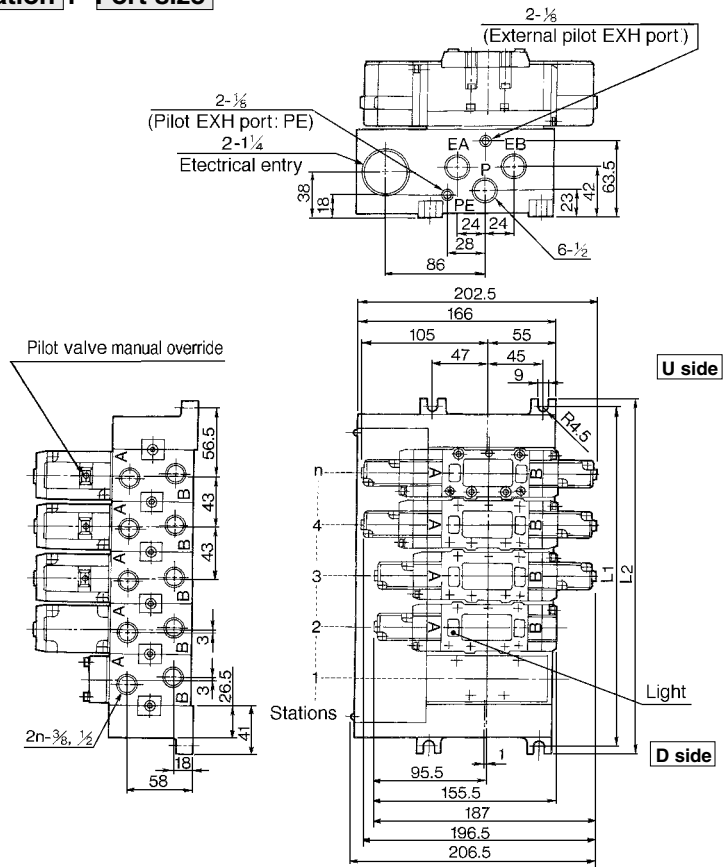

General formula of weight/Manifold $M=0.565n+0.923$ (kg) n:

Non plug-in: VV5FS4-10- Station 1- Port size

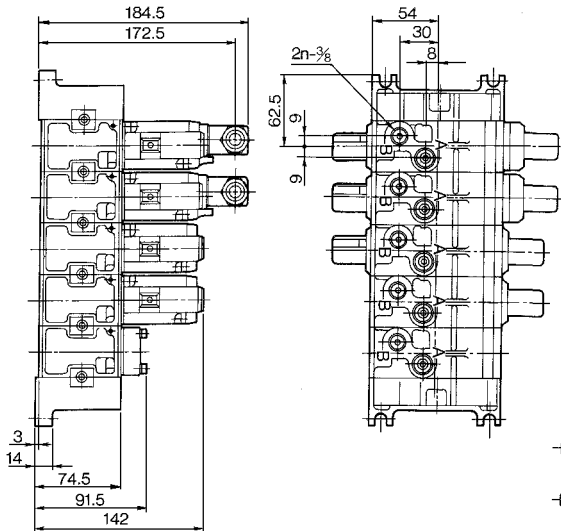

Bottom ported:
VV5FS4-10- Station 2- Port size

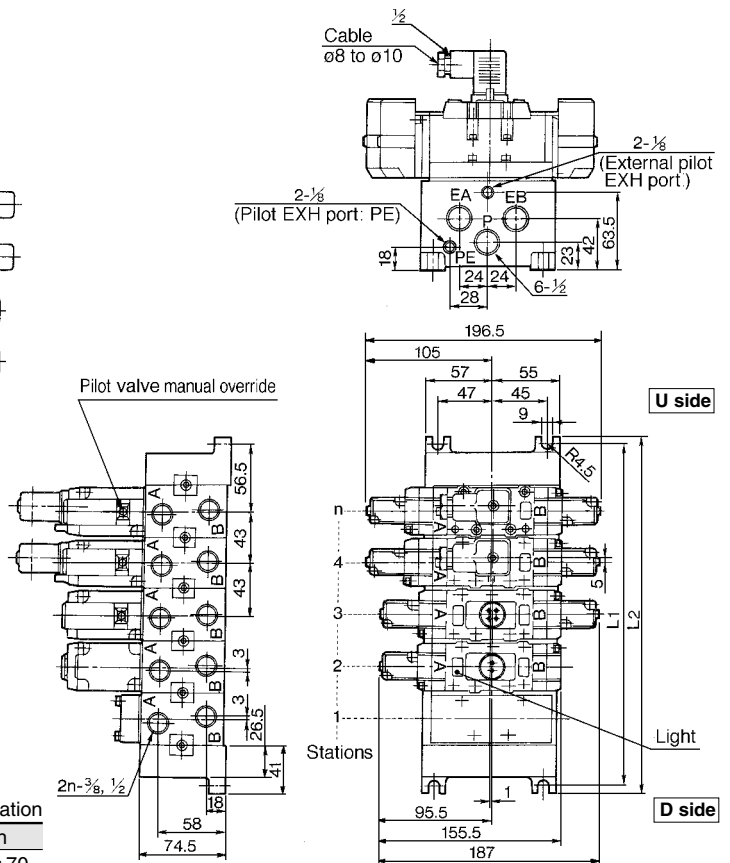

General formula of weight/Manifold $M=0.478n+0.671$ (kg) n: Station

n	2	3	4	5	6	7	8	9	10	Equation
L1	156	199	242	285	328	371	414	457	500	$L1=43 \times n + 70$
L2	168	211	254	297	340	383	426	469	512	$L2=43 \times n + 82$

VFS4000

Plug-in with Multi-Connector/With D-sub Connector

Plug-in with Multi-connector: **VV5FS4-01CD- Station 1- Port size**, **VV5FS4-01CU- Station 1- Port size**

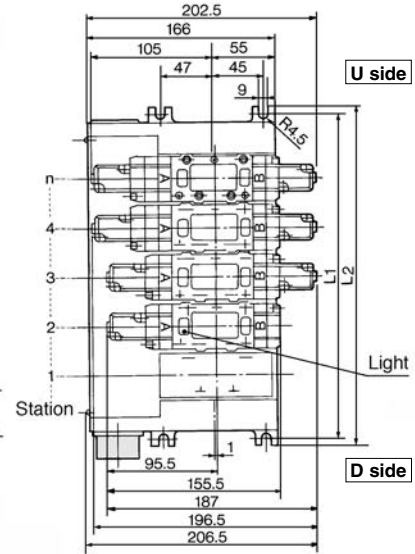
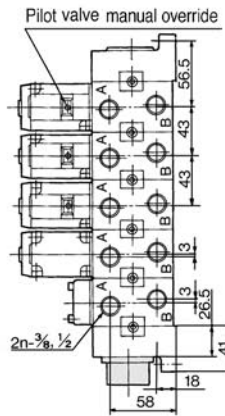
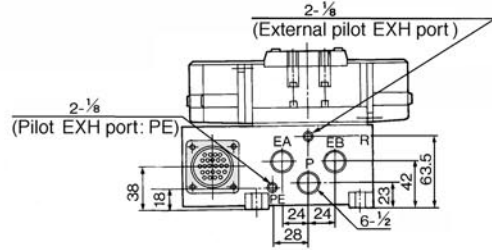
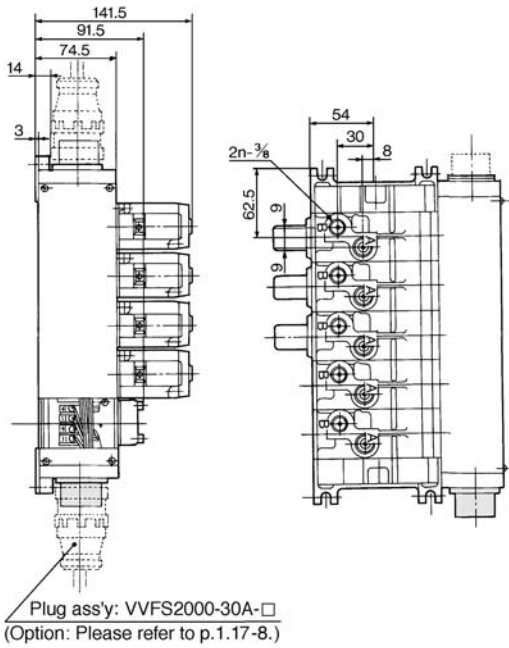

Bottom ported:

VV5FS4-01^{CD}_{CU} - Station 2- Port size

General formula of weight/Manifold $M=0.565n+0.923$ (kg) n: Station

*Wiring specifications: Please refer to p.1.17-8.



Plug-in with D-sub connector: **VV5FS4-01FD- Station 1- Port size**, **VV5FS4-01FU- Station 1- Port size**

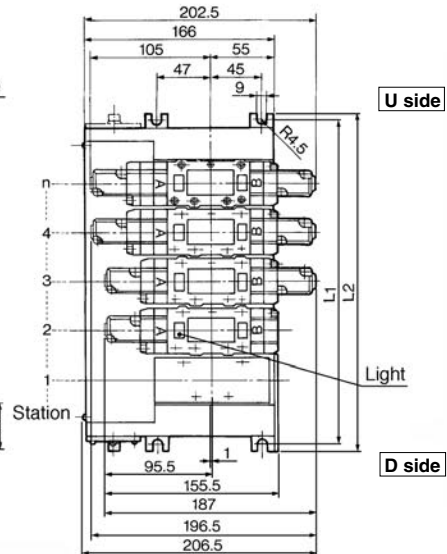
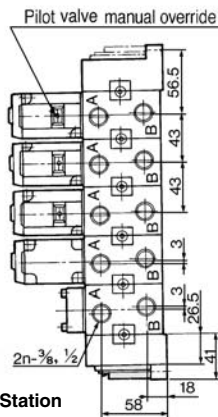
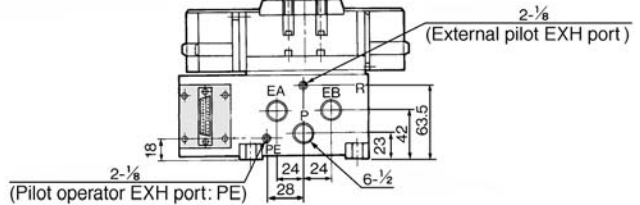
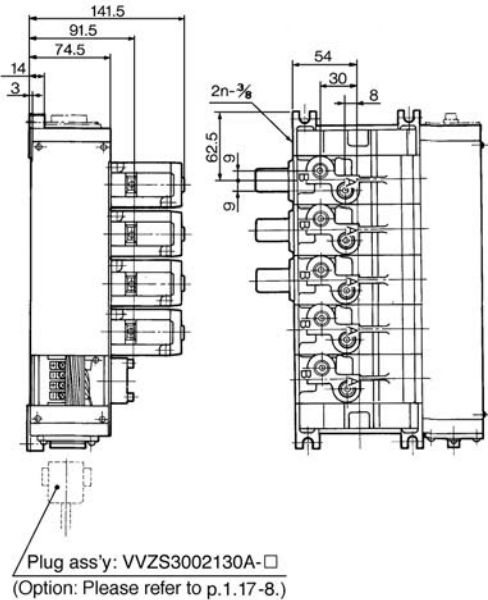

Bottom ported:

VV5FS4-01^{FD}_{FU} - Station 2- Port size

General formula of weight/Manifold $M=0.57n+0.935$ (kg) n: Station

*Wiring specifications: Please refer to p.1.17-8.



n	2	3	4	5	6	7	8	Equation
L1	156	199	242	285	328	371	414	$L1=43 \times n+70$
L2	168	211	254	297	340	383	426	$L2=43 \times n+82$



Manifold with Exhaust Cleaner

- Serves to protect work environment.
- Valve exhaust noise dampening: 35dB or more.
- Collection rate of drainage and oil mist: 99.9 % or more.
- Piping process reduced.

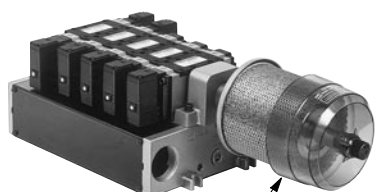

Plug-in

Exhaust cleaner (Optional)

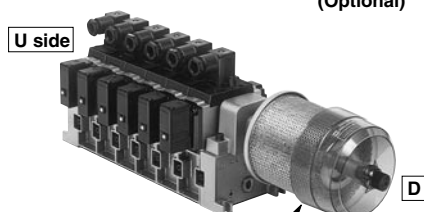

Non plug-in

Exhaust cleaner (Optional)

Manifold Specifications

Manifold style	Plug-in: VV5FS4-01□	Non plug-in: VV5FS4-10
Wiring	With terminal block With multi-connector With D-sub connector	DIN connector
Applicable valve	VFS4□00-□F	VFS4□10-□D
Porting	Common SUP, Common EXH	
	A, B port	Side: 3/8, 1/2, Bottom: 3/8 (option)
	P, EA, EB port	P: 1/2, EXH: 1 / 1 1/2
No. of stations	2 to 10 ⁽¹⁾	
Applicable exhaust cleaner	AMC610-10 (Connecting port size 1), AMC810-14 (Connecting port size 1 1/2) ⁽²⁾	



Note 1) With multi-connector, or with D-sub connector: 8 stations max.

Note 2) Stations of 5 or more and high frequency of operation should be used with AMC810-14. Exhaust cleaner AMC610-10 and AMC810-14 are not attached.

How to Order

VV5FS4-10-06-1-03-CD-Q

Series VFS4000 Manifold

Ordering source area code

Code	areas
-	Japan, Asia Australia
E	Europe
N	North America

Base style

01T	Plug-in with terminal block
01C	Plug-in with multi-connector
01F	Plug-in with D-sub connector
10	Non plug-in

Connector mounting direction

Symbol	With connector	Applicable base
-	None	01T, 10
D	D-side mounting	01C, 01F
U	U-side mounting	

Stations

02	2 stations
⋮	⋮
10	10 stations

Base style 01T, 10: 2-10 stations
Base style 01C, 01F: 2-8 stations

Exhaust cleaner mounting direction

Symbol	Exhaust cleaner mounting direction
CD	D side/D side mounting
CU	U side/U side mounting

*Please indicate exhaust cleaner size or port size.

Thread

-	Rc (PT)
N	NPT
T	NPTF
F	G (PF)

Port size

Symbol	P	A, B
03	1/2	3/8
04		1/2
M		Mix

*Bottom ported: Only 3/8.

Symbol

Symbol	Port specifications		Porting (A, B)
	P	EA, EB	
1	Common	Common	Side
2	Common	Common	Bottom*

*Option

⚠ Precautions

When using exhaust cleaner, mount it downwards.

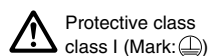

Refer to p.5.3-1 for details on exhaust cleaners.

Please indicate manifold base mounting style, corresponding valve, and option parts.

<<Example>>

•Plug-in with terminal block (6 stations)
(Manifold base) **VV5FS4-01T-061-03-CD-Q** 1
(2 position single) **VFS4100-5FZ-Q** 3
(2 position double) **VFS4200-5FZ-Q** 2
(Blank plate) **VVFS4000-10A** 1
(Exhaust cleaner) **AMC610-10** 1

•Non plug-in (6 stations)
(Manifold base) **VV5FS4-10-061-04-CU-Q** 1
(2 position single) **VFS4110-5D-Q** 3
(2 position double) **VFS4210-5D-Q** 2
(Blank plate) **VVFS4000-10A** 1
(Exhaust cleaner) **AMC810-14** 1

VFS4000

Manifold with Exhaust

Plug-in/Non Plug-in

Plug-in: VV5FS4-01T- Station 1- Port size CD

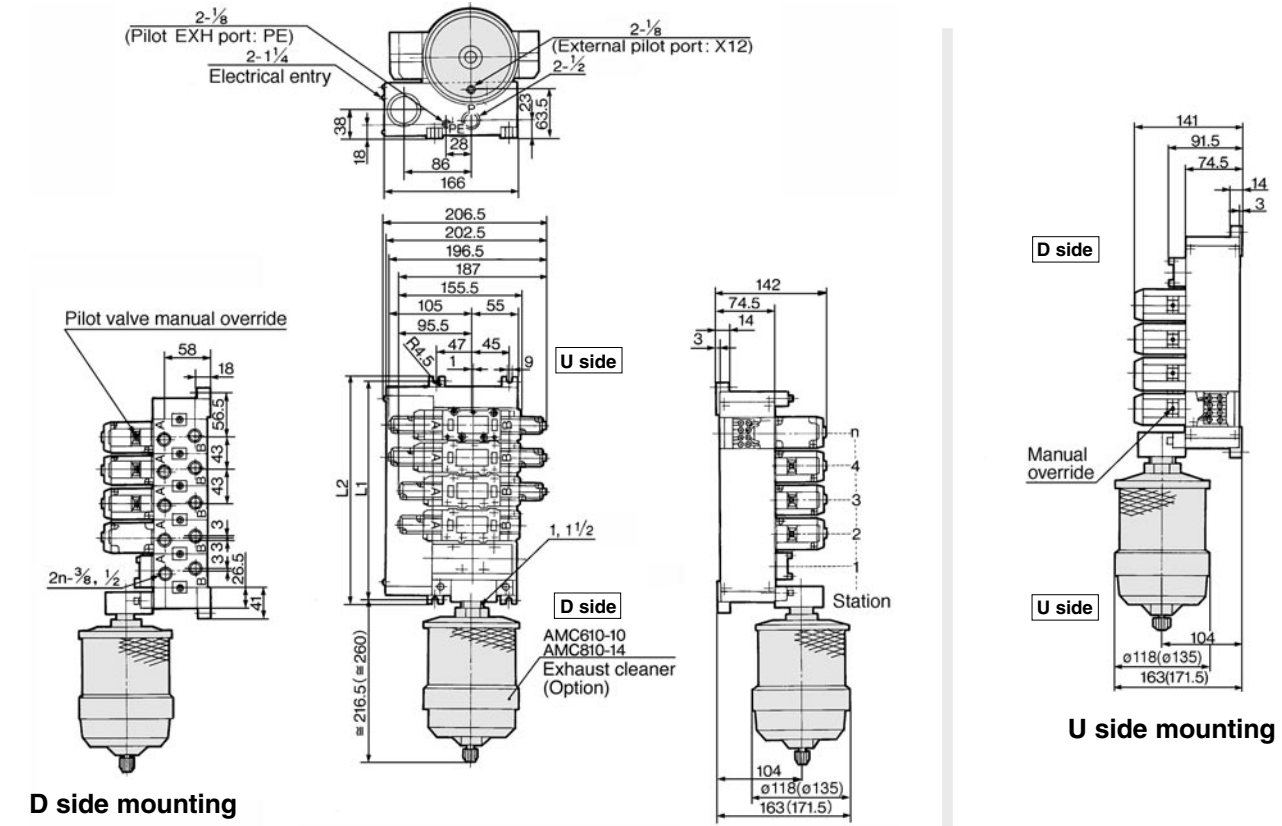

D side mounting

() : AMC810

Non plug-in: VV5FS4-10- Station 1- Port size CD

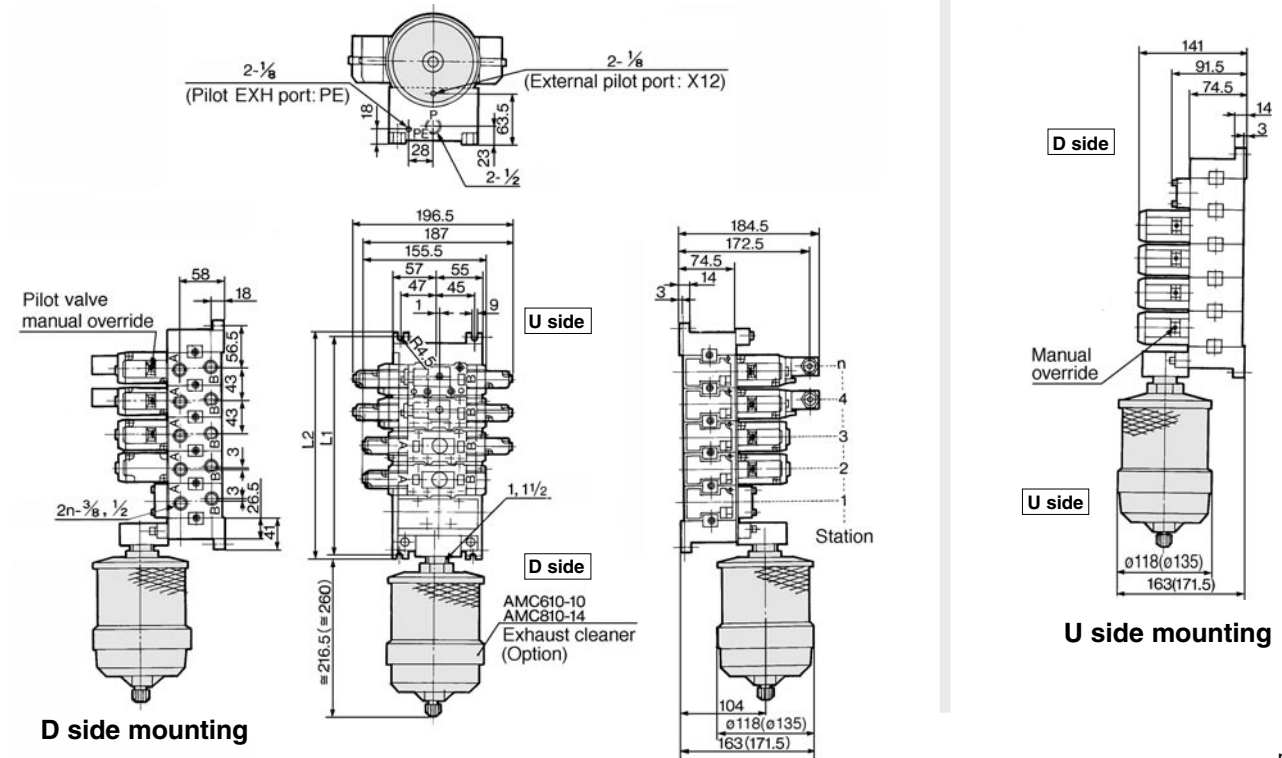

D side mounting

() : AMC810

n: Station

L	n	2	3	4	5	6	7	8	9	10	Equation
L ₁		156	199	242	285	328	371	414	457	500	L ₁ =43 X n+70
L ₂		168	211	254	297	340	383	426	469	512	L ₂ =43 X n+82

Manifold with Control Unit

•Control unit (Filter, Regulator, Pressure switch, Air release valve) are all standardized to the one unit, and can be mounted on the manifold base without any attachments.

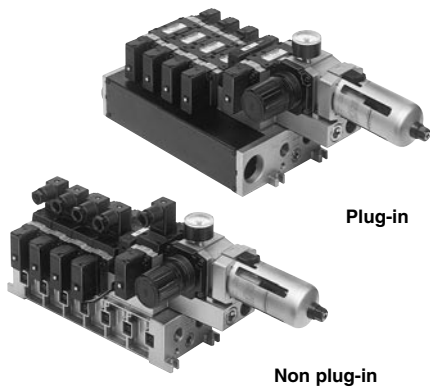

Manifold Specifications

Manifold style	Plug-in: VV5FS4-01□	Non plug-in: VV5FS4-10
Wiring	With terminal block With multi-connector With D-sub connector	DIN connector
Applicable valve	VFS4□00-□F	VFS4□10-□D
Porting specifications	Common SUP, Common EXH	
	A, B port	Side: 3/8, 1/2, Bottom: 3/8
	P, EA, EB port	Side: 1/2
No. of stations	2 to 10 ⁽¹⁾	

⦿ * With multi-connector, or with D-sub connector: 8 stations max.

Control Unit/Specifications

Air filter (With auto drain/With manual drain)	
Filtration	5 μm
Regulator	
Set press. (Secondary)	0.05 to 0.85MPa
Pressure switch ⁽¹⁾	
Set press. range: OFF	0.1 to 0.6MPa
Differential	0.08MPa or less
Contact	1a
Light	LED (RED)
Max. switch capacity	2VA (AC), 2W (DC)
Max. operating current	24V AC, DC or less: 50mA
Air release valve (Single only)	
Operating press. range	0.1 to 1.0MPa

Control Unit/Options

Air release valve adaptor plate ⁽²⁾	<Plug-in> VVFS4000-24A-1R (D side mounting)	
	<Non Plug-in> VVFS4000-24A-2R (D side mounting)	
Pressure switch	IS1000P-2-1	
Blank plate ⁽³⁾	With control unit/Filter regulator	MP2-3
	Pressure switch	MP3-2
	Air release valve	VVFS4000-24A-10
Filter element	11104-5B	

⦿ Note 1) Voltage: 24V DC to 100V AC
Inner voltage drop: 4V
Note 2) Combination of a valve VFS41□□ (single) and a release valve spacer can be used as an air release valve.
Note 3) The non plug-in style cannot be

⚠ Precautions

When using an air filler with auto drain or manual drain, mount the filter vertically.

How to Order

VV5FS4-01C D-08 1-03 AP-Q

Series VFS4000 Manifold

Ordering source area code

Code	areas
-	Japan, Asia Australia
E	Europe
N	North America

Base style/wiring

01T	Plug-in with terminal block
01C	Plug-in with multi-connector
01F	Plug-in with D-sub connector
10	Non plug-in

Connector mounting direction

Symbol	Connector mounting	Applicable base
-	None	01T, 10
D	D side	01C, 01F
U	U side	01C, 01F

Stations

02	2 stations
⋮	⋮
10*	10 stations

* Base style 01T, 10: 2 to 10 stations
Base style 01C, 01F: 2 to 8 stations

Symbol

Symbol	Port specifications	Porting (A, B)
1	P, EA, EB	Side
2	Common	Bottom*

* Option

Port size

Symbol	P, EA, EB	A, B
03		3/8
04	1/2	1/2
M		Mix

Thread

-	Rc (PT)
N	NPT
T	NPTF
F	G (PF)

⦿ *Bottom ported: Only 3/8.

Voltage of air release valve

-	None (F, G type only)
5	24V DC
9	Other (50 or less)

⦿ Contact SMC for other voltages (9)

Control unit

Control apparatus	Symbol	-	A	AP	M	MP	F	G	C	E
Air filter with auto drain			●	●			●			
Air filter with manual drain					●	●		●		
Regulator			●	●	●	●		●		
Air release valve			●	●	●	●			●	●
Pressure switch*				●		●				
Blank plate (Air release valve)							●	●		
Blank plate (Filter, Regulator)									●	
Mounting manifold block			2 stations	2 stations	2 stations	2 stations	2 stations	2 stations	2 stations	1 station

Please indicate manifold base mounting style, corresponding valve, and option parts.

<<Example>> • Plug-in with terminal block In order to mount control unit, it requires 2 stations.
(Manifold base) **VV5FS4-01T-081-03-AP-Q** 1
(2 position single) **VFS4100-5FZ-Q** 4
(2 position double) **VFS4200-5FZ-Q** 2

• Non Plug-in - In order to mount control unit, it requires 2 stations.
(Manifold base) **VV5FS4-10-061-03-A-Q** 1
(2 position single) **VFS4110-5D-Q** 4

VFS4000

Manifold with control

Plug-in/Non Plug-in

Plug-in: VV5FS4-01T- Station 1- Port size -AP

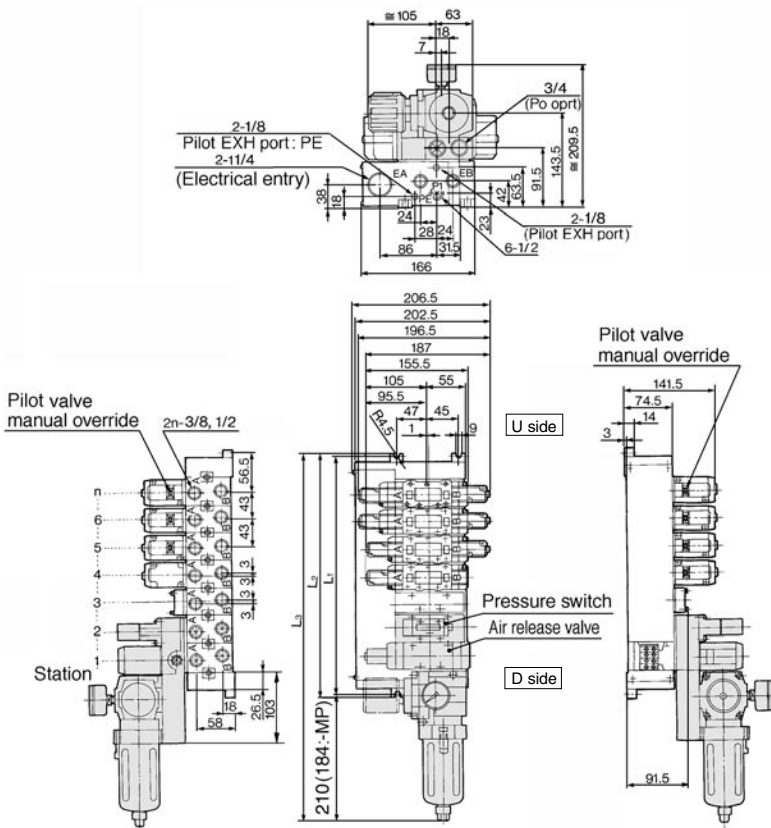

Example for manifold

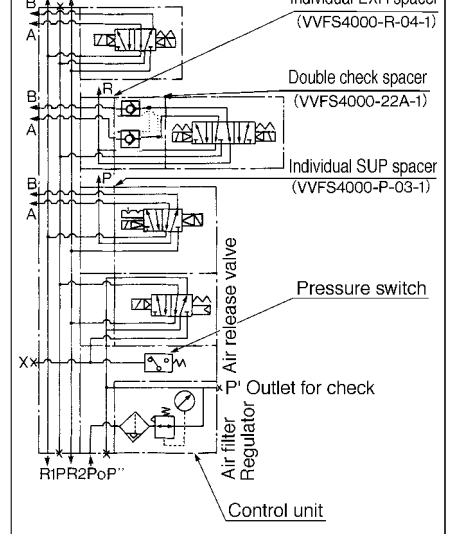

Non plug-in: VV5FS4-10- Station 1- Port size -AP

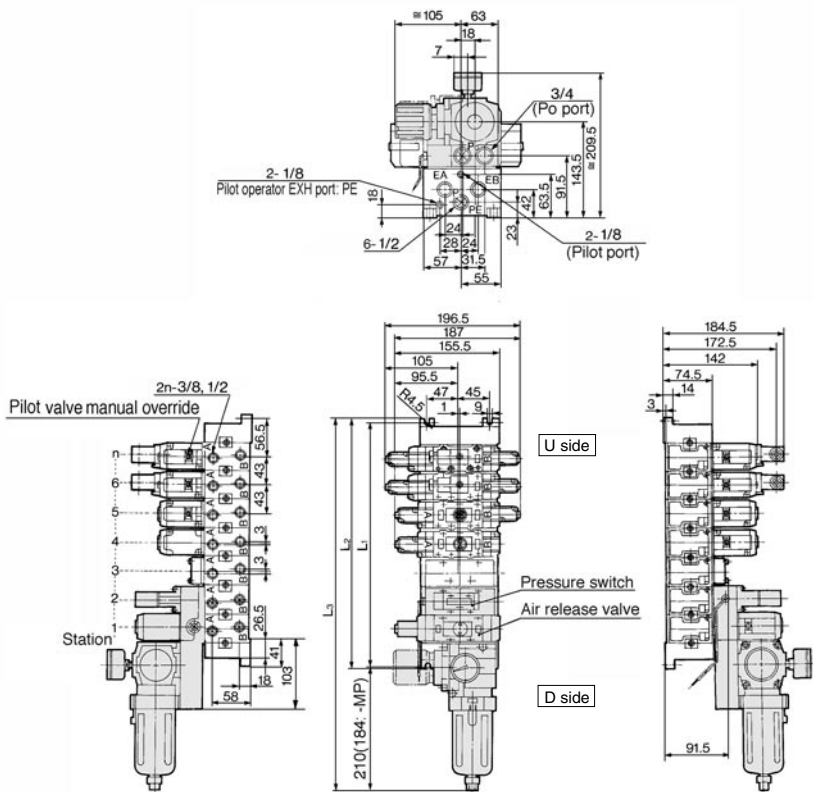

Example for manifold

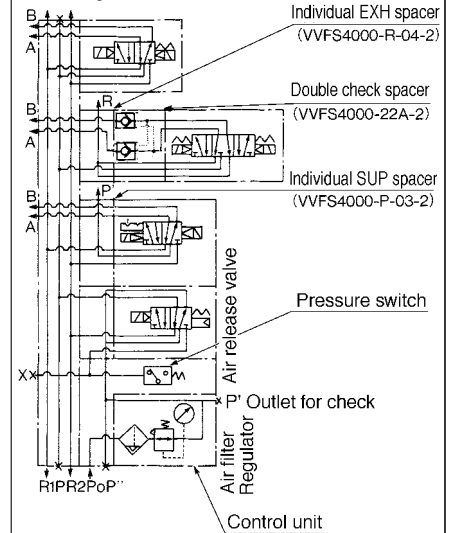

n: Station

n	3	4	5	6	7	8	9	10	Equation
L1	199	242	285	328	371	414	457	500	$L1=43 \times n+70$
L2	211	254	297	340	383	426	469	512	$L2=43 \times n+82$
L3 (MP)	385.5	428.5	471.5	514.5	557.5	600.5	643.5	686.5	$L3=43 \times n+256.5$
L3 (AP)	427	470	513	556	599	642	685	728	$L3=43 \times n+298$

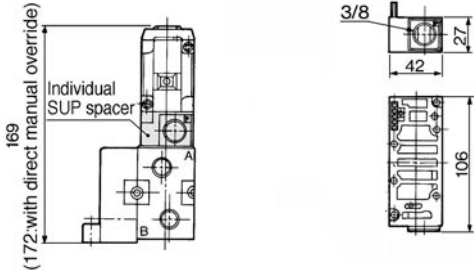
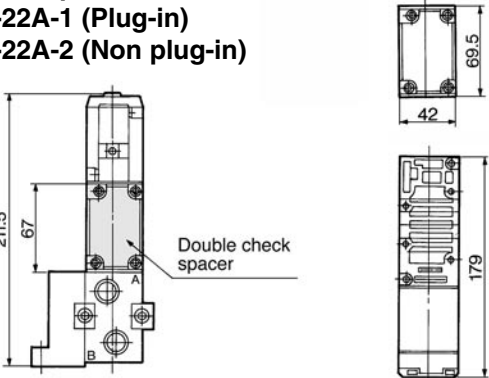
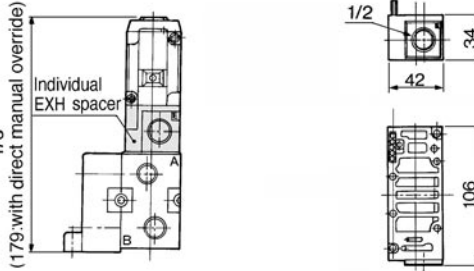
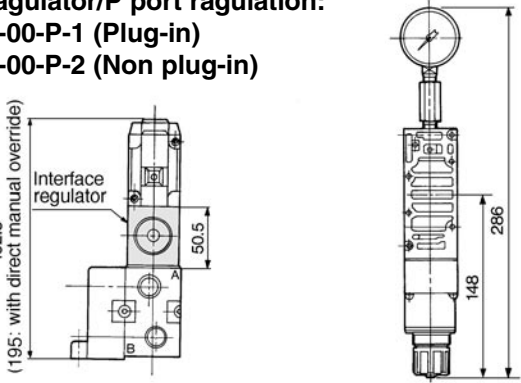
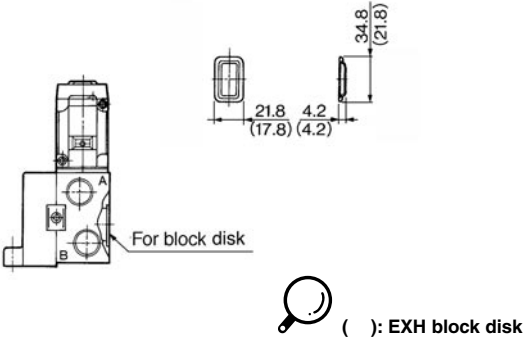
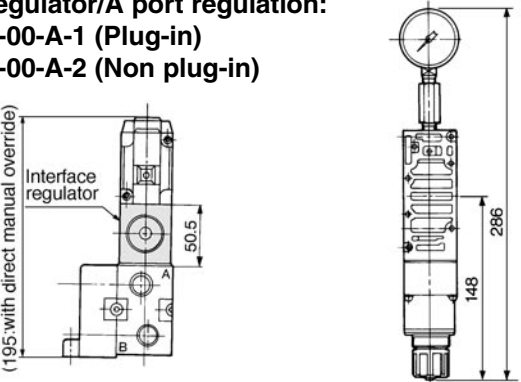
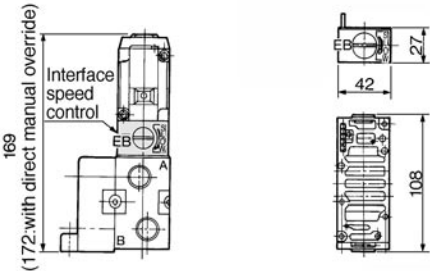
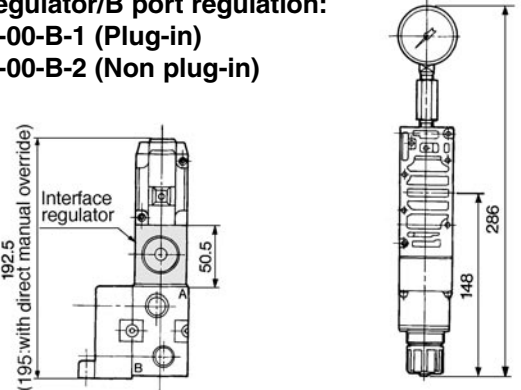
Manifold Optional	Plug-in/Non Plug-in
<p>Individual SUP spacer: VVFS4000-P-03-1 (Plug-in) VVFS4000-P-03-2 (Non plug-in)</p> 	<p>Double check spacer: VVFS4000-22A-1 (Plug-in) VVFS4000-22A-2 (Non plug-in)</p> 
<p>Individual EXH spacer: VVFS4000-R-04-1 (Plug-in) VVFS4000-R-04-2 (Non plug-in)</p> 	<p>Interface regulator/P port regulation: ARBF4050-00-P-1 (Plug-in) ARBF4050-00-P-2 (Non plug-in)</p> 
<p>SUP block disk: AXT634-10A EXH block disk: AXT634-11A</p>  <p>() : EXH block disk</p>	<p>Interface regulator/A port regulation: ARBF4050-00-A-1 (Plug-in) ARBF4050-00-A-2 (Non plug-in)</p> 
<p>Interface speed control: VVFS4000-20A-1 (Plug-in) VVFS4000-20A-2 (Non plug-in)</p> 	<p>Interface regulator/B port regulation: ARBF4050-00-B-1 (Plug-in) ARBF4050-00-B-2 (Non plug-in)</p> 

VFS4000

Manifold Base Construction Plug-in/Non Plug-in

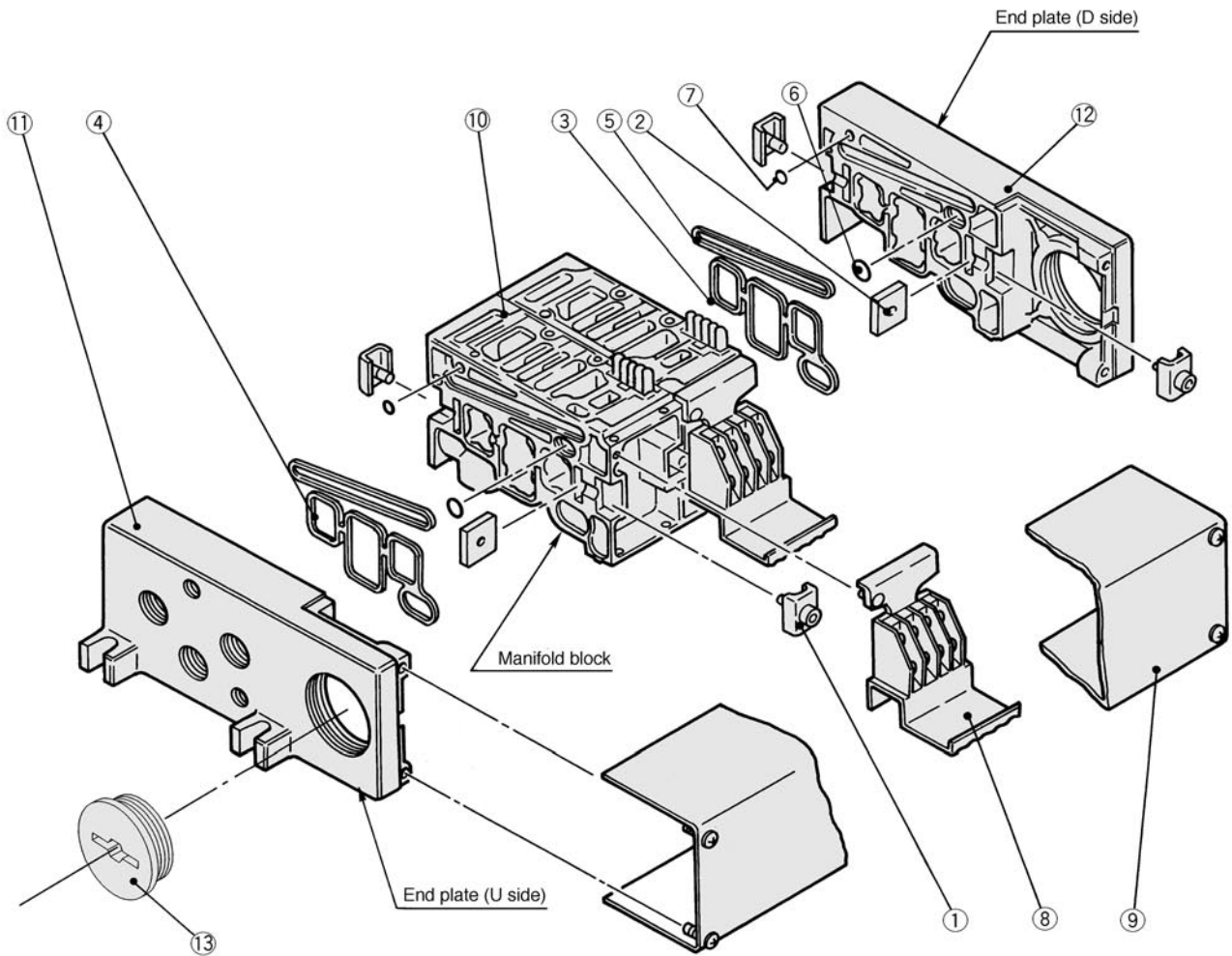

Replacement Parts

No.	Description	Material	Part No.
①	Metal joint A	Steel plate	VVF4000-5-1A
②	Metal joint B	Steel plate	VVF4000-5-2
③	Gasket	NBR	VVF4000-7 (For end plate)
④	Gasket	NBR	VVF4000-7-1 (For manifold block)
⑤	Gasket	NBR	VVF4000-8
⑥	O ring	NBR	AS568-011
⑦	O ring	NBR	P-3
⑧	Terminal assembly	—	VVFS4000-6A
⑨	Junction cover assembly	01T	VVF4000-4A- <small>stations</small>
		01SU	AZ738-30A- <small>stations</small>
⑬	Rubber plug	NBR	AXT336-9

•For increasing the manifold bases, please order the manifold block assembly number of the principal part assembly ⑩. For plug-in: The manifold base with terminal stand (integrated with a junction cover) is required with the ⑨ junction cover assembly.

Replacement Parts Sub-assembly



Note) Manifold Base/Construction: Plug-in with terminal block.

No.	Description	Assembly No.	Component parts	Applicable manifold base
⑩	Manifold block assembly	VVF4000-1A-1- <small>03</small> / <small>04</small>	Manifold block ⑩, Terminal ⑧, Metal joint ①, ②, Gasket ④, Receptacle assembly	Plug-in
		VVF4000-1A-2- <small>03</small> / <small>04</small>	Manifold block ⑩, Metal joint ①, ②, Gasket ④	Non Plug-in
⑪	End plate assembly (U side)	VVF4000-2A-1	End plate(U) ⑪, Metal joint ①, ②	Plug-in
		VVF4000-2A-2	End plate(U) ⑪, Metal joint ①, ②	Non Plug-in
⑫	End plate assembly (D side)	VVF4000-3A-1	End plate(D) ⑫, Metal joint ①, ②, Gasket ③, ⑤, O ring ⑥, ⑦	Plug-in
		VVF4000-3A-2	End plate(D) ⑫, Metal joint ①, ②, Gasket ③, ⑤, O ring ⑥, ⑦	Non Plug-in

5 Port Pilot/Metal Seal Plug-in/Non Plug-in Series VFS5000

Compact despite large flow capacity 3/4: N/min 5595

Small Power Consumption/1.8W DC

Easy to maintain

2 styles of sub-plates: plug-in and non plug-

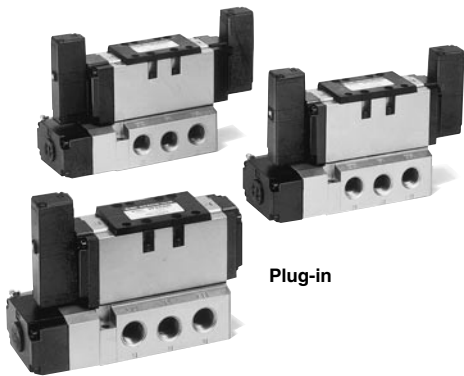

Plug-in

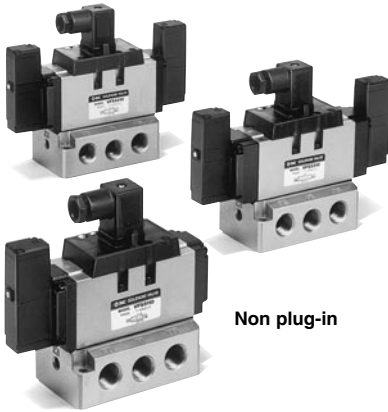

Non plug-in

JIS Symbol

2 position	3 position
Single	Closed centre
Double	Exhaust centre
	Pressure centre
	Double check

Model

Configuration	Model		Port size	Effective area (mm ²) (N/min)	Max. operating cycle (CPM) ⁽¹⁾	Response time (ms) ⁽²⁾	Weight (kg) ⁽³⁾	
	Plug-in	Non plug-in						
2 position	Single	VFS5100	VFS5110	3/8	78.7 (4319)	600	45 or less	0.88
				1/2	97.2 (5300)			
				3/4	102.6 (5595)			
2 position	Double	VFS5200	VFS5210	3/8	78.7 (4319)	600	25 or less	1.06
				1/2	97.2 (5300)			
				3/4	102.6 (5595)			
2 position	Closed centre	VFS5300	VFS5310	3/8	67.1 (3632)	300	55 or less	1.16
				1/2	82.8 (4515)			
				3/4	86.4 (4711)			
	Exhaust centre	VFS5400	VFS5410	3/8	70.0 (3828)	300	55 or less	1.14
				1/2	86.4 (4711)			
				3/4	90.0 (4907)			
	Pressure centre	VFS5500	VFS5510	3/8	70.0 (3828)	300	55 or less	1.14
				1/2	86.4 (4711)			
				3/4	88.2 (4809)			
Double check	VFS5600	VFS5610	3/8	39.4 (2159)	180	60 or less	1.99	
			1/2	48.6 (2650)				
			3/4	50.4 (2748)				



Note 1) According to JIS B8375 (Once per 30 days) for the minimum operating frequency.

Note 2) According to JIS B8375-1981. (The value at supply pressure 0.5MPa.)

Note 3) The figures in the above list are without sub plate. In the case of with plug-in sub-plate, and with non plug-in sub-plate add 3/8, 1/2-0.744kg, 3/4-0.966kg and 3/8, 1/2-0.577kg, 3/4-0.823kg respectively.

Note 4) "Note 1)" and "Note 2)" are with controlled clean air.

Standard Specifications

Valve	Fluid	Air, inert gas		
	Max. operating pressure	1.0MPa		
	Min. operating pressure	0.1MPa		
	Proof pressure	1.5MPa		
	Ambient and fluid temperature	-10 to +60°C ⁽¹⁾		
	Lubrication	Not required ⁽²⁾		
	Pilot valve manual override	Non-locking push (Flush)		
	Shock/vibration resistance	150/50m/s ² ⁽³⁾		
Solenoid	Protection structure	E type: dust proof (Protection level 0), F type: drip proof (Protection level 2), D type: splash proof (Protection level 4) ⁽⁴⁾		
	Rated voltage	100V, 200V AC, 50/60Hz, 24V DC		
	Allowable voltage	-15 to +10% rated voltage		
	Coil insulation	Class B or equivalent ⁽⁵⁾		
	Apparent power (Power consumption) AC	Inrush	5.6VA/50Hz, 5.0VA/60Hz	
		Holding	3.4VA (2.1W)/50Hz, 2.3VA (1.5W)/60Hz	
	Power consumption DC	1.8W		
	Electrical entry	Plug-in	Conduit terminal	
Non Plug-in		DIN connector		



Note 1) Use dry-air at low temperatures.

Note 2) Use turbine oil No.1 (ISO VG32), if lubricated

Note 3) Shock resistance: No malfunction from test using drop impact tester to axis and right angle directions of main valve and armature, each one time when energized and de-energized.

Vibration resistance: No malfunction from test with 8.3 to 2000Hz 1 sweep, to axis and right angle directions of main valve and armature, each one when energized and de-energized. (Value in the initial stage.)

Note 4) According to JIS C0920. Note 5) According to JIS C4003.

Option Specifications

Pilot		External pilot ⁽¹⁾
Manual override	Main valve	Direct manual override
	Pilot valve	Non-locking push style (Extended), Locking style (Slotted), Locking style (Lever)
Voltage		110V to 120V, 220V, 240V AC (50/60Hz)
		12V, 100V DC
Porting		Bottom porting
Option		With indicator light and surge voltage suppressor, Non-rotating DIN connector



Note 1) Operating pressure: 0 to 1.0MPa Pilot pressure ——— 0.1 to 1.0MPa

VFS5000

How to Order

Ordering source area code

Code	areas
-	Japan, Asia Australia
E	Europe
N	North America

Body

O: Plug-in sub-plate

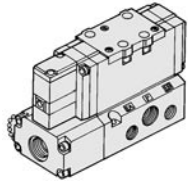

Electrical entry

F: Plug-in conduit with terminal

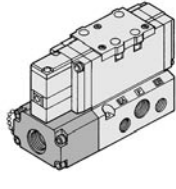

Porting

	Side
B*	Bottom

*Option
Bottom piping
not available for
external pilot
specification

Port size

	Without sub-plate
03	3/8
04	1/2
06	3/4

Thread

	Rc (PT)
N	NPT
T	NPTF
F	G (PF)



Plug-in

VFS5 1 0 0 2 F 04 -Q

Non plug-in

VFS5 1 1 0 5 D 06 -Q



Configuration

1 2 position single	5 3 position pressure centre
2 2 position double	6 3 position double check
3 3 position closed centre	
4 3 position exhaust centre	

Body

1: Non plug-in sub-plate

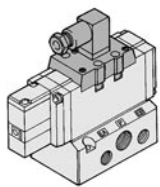

Body option

0	Standard
1*	Direct manual override

* Option

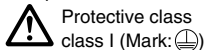

Protective class
class I (Mark: ⚡)

Option

-	None
Z	With indicator light and surge voltage suppressor
P*	Non-rotating DIN connector
ZP*	With indicator light and surge voltage suppressor, Non-rotating DIN connector

* P, ZP: DIN type only.

Electrical entry

D: DIN connector
DO: without DIN
connector

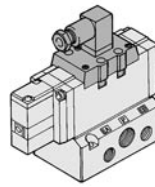

Y: DIN connector
(DIN 43650B)
YO: without
DIN connector

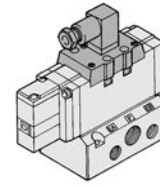

Voltage

1	100V AC 50/60Hz
2	200V AC 50/60Hz
3	110 to 120V AC 50/60Hz
4	220V AC 50/60Hz
5	24V DC
6	12V DC
7	240V AC 50/60Hz
9	Other (250 or less)

Contact SMC
for other voltages (9)

Pilot

-	Internal
R*	External

* Option

Pilot valve manual override

-: Non-locking push style
(Flush)

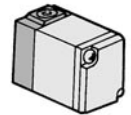

A*: Non-locking push style
(Extended)

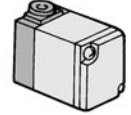

B*: Locking style (Slotted)

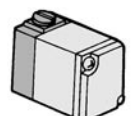

C*: Locking style (Lever)

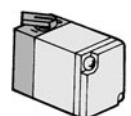

* Option

How to Order Pilot Valve Assembly

SF4 - 1 F 30 - Q

Voltage

1	100V AC 50/60Hz
2	200V AC 50/60Hz
3	110 to 120V AC 50/60Hz
4	220V AC 50/60Hz
5	24V DC
6	12V DC
7	240V AC 50/60Hz
9	Other(250 or less)

Manual override

-	Non-locking push style (Flush)
A*	Non-locking push style (Extended)
B*	Locking style (Slotted)
C*	Locking Style (Lever)

* Option

Contact SMC
for other voltages (9)



* Refer to p.1.17-5 for voltage conversion.

Maximum Cylinder Speed

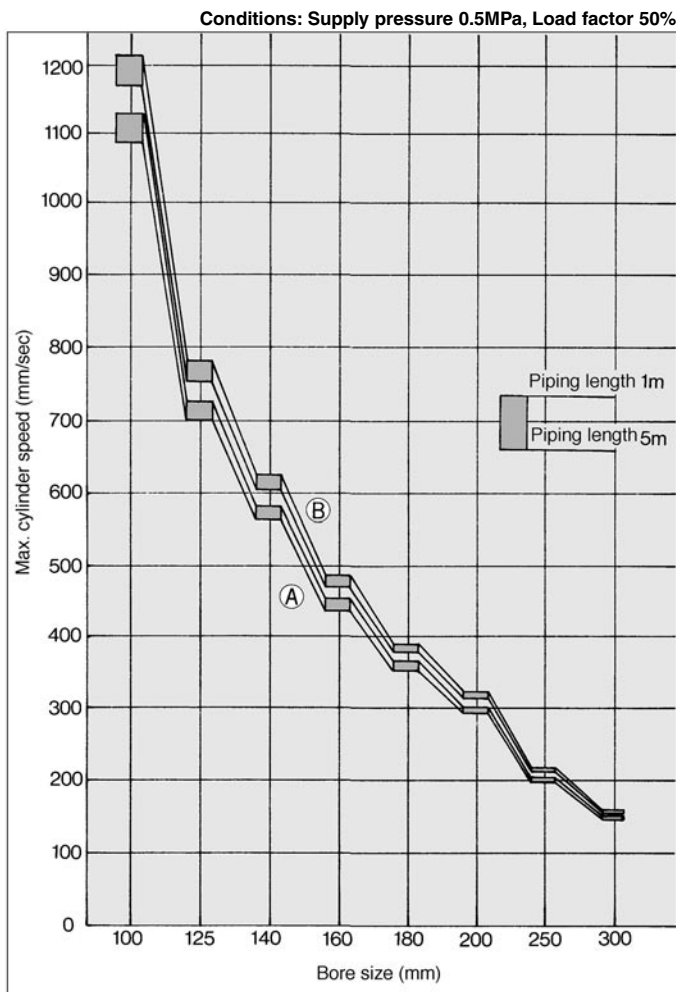

System diagram

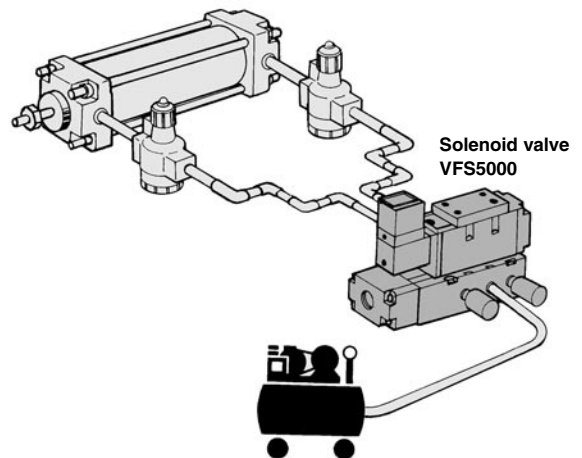

Rubber hose piping system

Symbol	Solenoid valve	Speed controller	Silencer	Piping
A	VFS5000-06 {3/4} (S=102.6mm ²)	AS500-06 {3/4} (S=120mm ²)	AN500-06 {3/4} (S=160mm ²)	3/4 B (Fittings 4 pcs.)

S. G. P. Piping system

Symbol	Solenoid valve	Speed controller	Silencer	Piping
B	VFS5000-06 {3/4} (S=102.6mm ²)	AS500-06 {3/4} (S=120mm ²)	AN500-06 {3/4} (S=160mm ²)	3/4 B (Fittings 4 pcs.)

Double Check Spacer/Specification

Holding cylinder mid-position for a long periods

The concurrent use of double check spacer with built-in double check valve can stop cylinder or mid-position and hold it without being affected by air leakage spool seals.

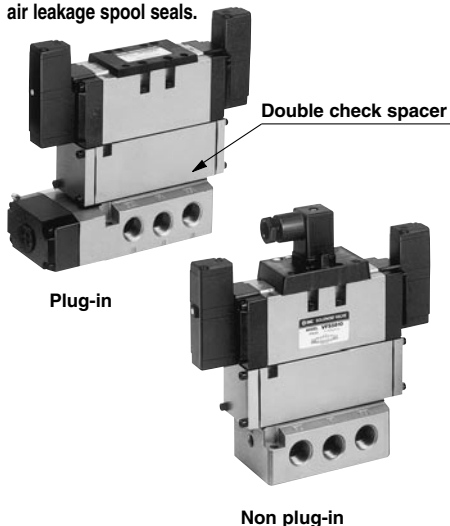

Specifications

Double check spacer	Plug-in	Non plug-in
	VVFS5000-22A-1	VVFS5000-22A-2
Applicable solenoid valve	VFS5400-□F	VFS5410-□D
Leakage (cm ³ /min)*	Solenoid one side energized	P EA 320 or less
		P EB 320 or less
	Solenoid both sides de-energized	A EA 0
		B EB 0

*Supply pressure: 0.5MPa

⚠ Precautions

- In the case of 3 position double check valve (VFS56□0), check the leakage from piping and fittings in between valve and cylinder by means of synthetic detergent solutions, and ensure that there is no such leakage found there. Also check the leakage from cylinder seal and piston seal. If there is any leakage, sometimes the cylinder, when valve is de-energized, can move without stopping at mid-position.
- Be aware that if the exhaust side is restricted excessively, the intermediate stopping accuracy will decrease and will lead to improper intermediate stops.

Check Valve Operation

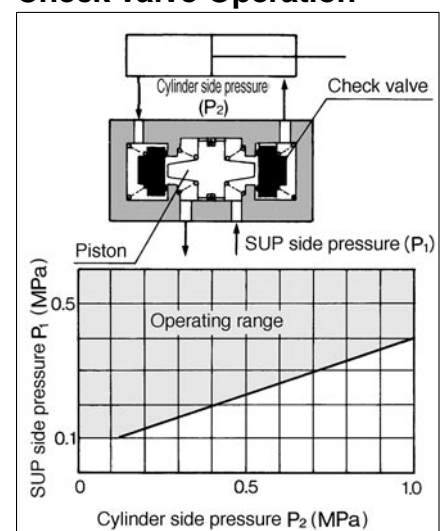

- The combination of VFS51□0, VFS52□0 and a double check spacer can be used as prevention of falling at the stroke end but cannot hold the intermediate position of the cylinder.

VFS5000

Construction

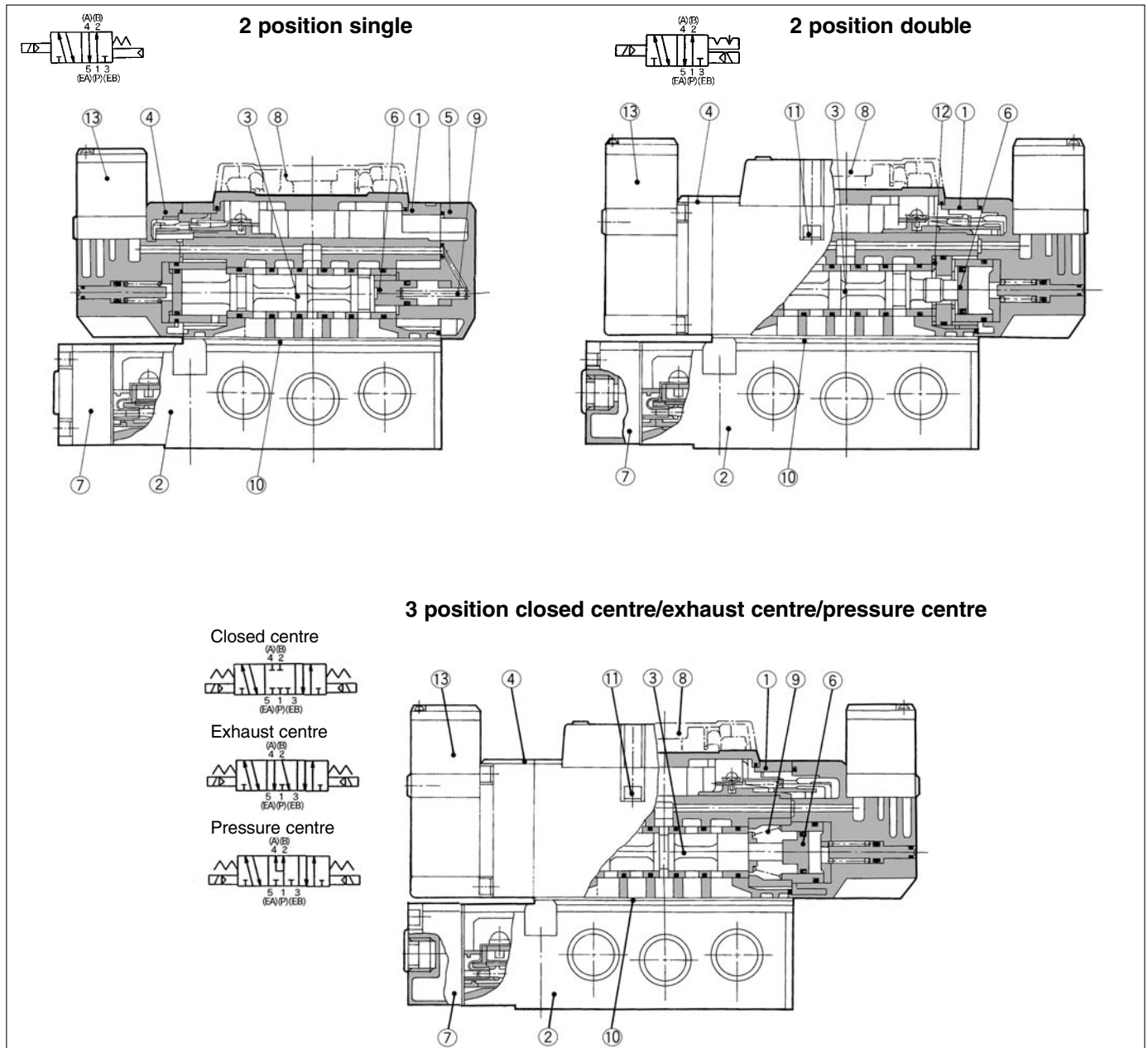

Component Parts

No.	Description	Material	Note
①	Body	Aluminium die cast	Platinum silver
②	Sub plate	Aluminium die cast	Platinum silver
③	Spool/Sleeve	Stainless steel	
④	Adaptor plate	Aluminium die cast	Black
⑤	End plate	Aluminium die cast	Black
⑥	Piston	Resin	
⑦	Junction cover	Resin	
⑧	Light cover	Resin	

Sub-plate Assembly

Plug-in	VFS5000-P- ⁰³ ₀₄ ₀₆
Non Plug-in	VFS5000-S- ⁰³ ₀₄ ₀₆



* Without mounting screw and gasket.

Replacement Parts

No.	Description	Material	Part No.		
			VFS51□□	VFS52□□	VFS53□□, 54□□, 55□□
⑨	Return spring	Stainless steel	VFS5000-9	—	AXT627-18
⑩	Gasket	NBR	AXT627-10-1	AXT627-10-1	AXT627-10-1
⑪	Hexagonal socket head cap screw	Steel	M5 X 50	M5 X 50	M5 X 50
⑫	Detent assembly	—	—	AXT510-9	—
⑬	Pilot valve assembly	—	—	—	—

Refer to "How to order Pilot valve assembly" on p.1.17-86.

Plug- 2 Position Single/Double, 3 Position Closed Centre/Exhaust Centre/Pressure Centre/Double

2 position single: VFS5100-□F

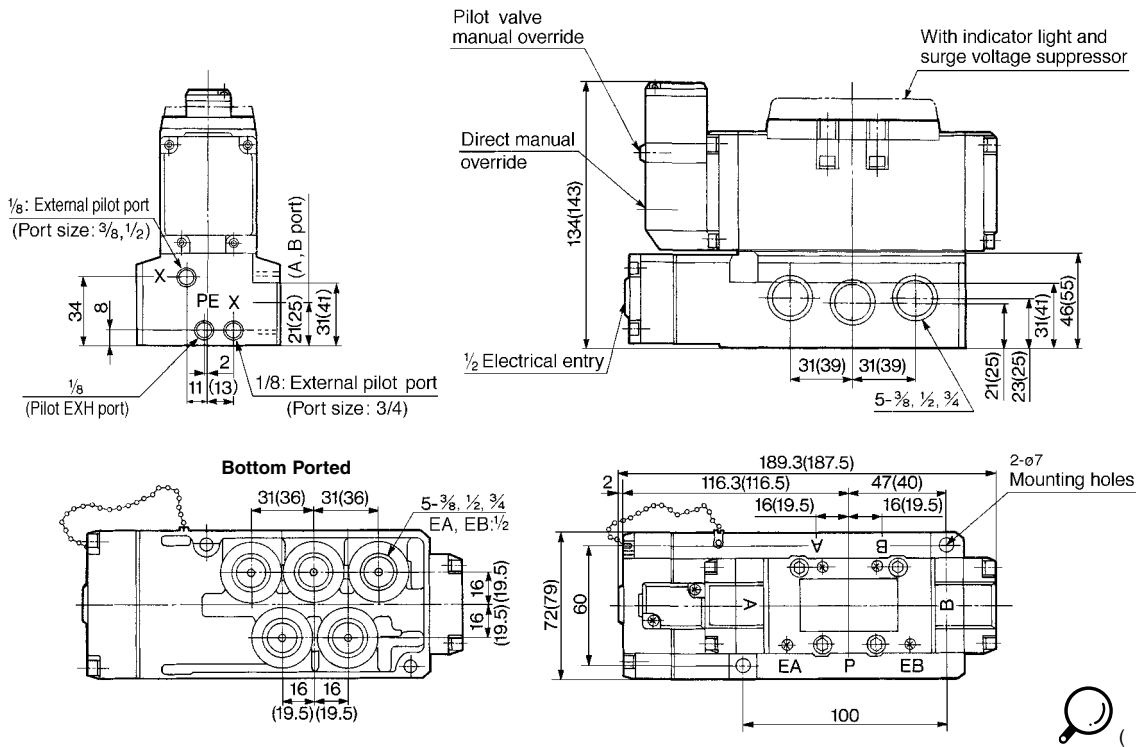

2 position double: VFS5200-□F

3 position closed centre: VFS5300-□F

3 position exhaust centre: VFS5400-□F

3 position pressure centre: VFS5500-□F

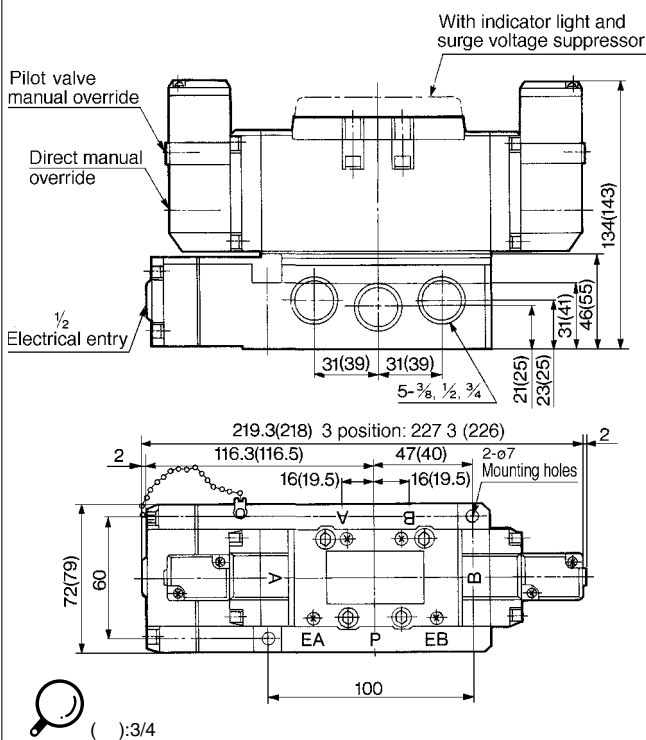

3 position double check: VFS5600-□F

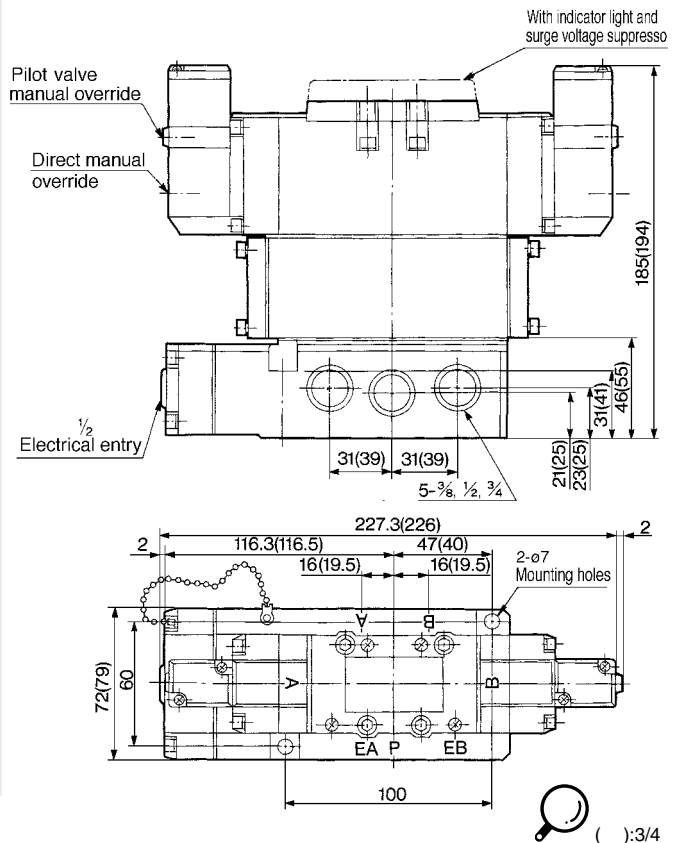

Non Plug- 2 Position Single/Double, 3 Position Closed Centre/Exhaust Centre/Pressure Centre/Double

2 position single: VFS5110-□D

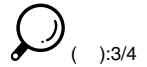
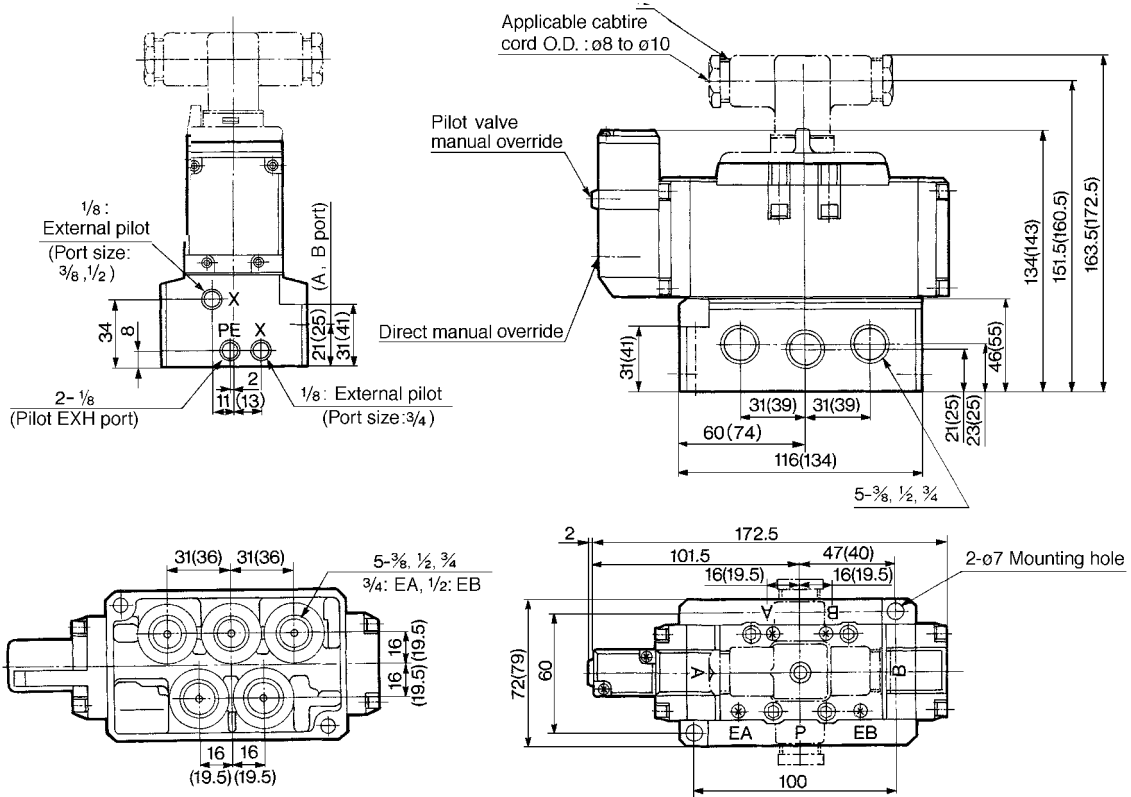

2 position double: VFS5210-□D

3 position closed centre: VFS5310-□D

3 position exhaust centre: VFS5410-□D

3 position pressure centre: VFS5510-□D

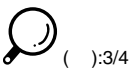
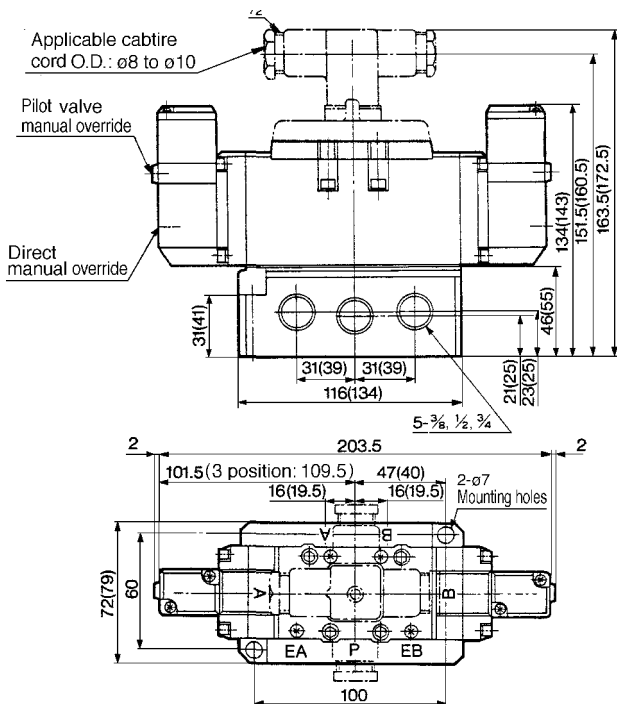

3 position double check: VFS5610-□D

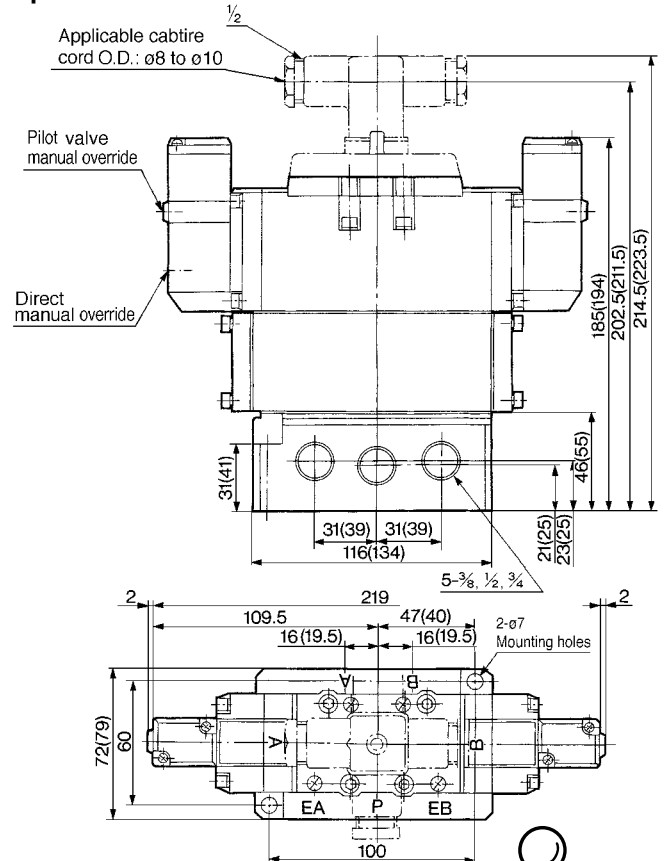

Series VFS5000 Manifold

Plug-in: With Terminal Block

•Since lead wires of solenoid valve are connected with the terminals on upper surface of terminal block, corresponding lead wires from power source can be wired at the bottom of terminal block.

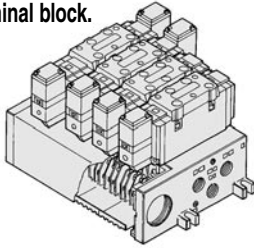

VV5FS5 - 01T - 06 1 - 04 - Q

Series VFS5000 Manifold
Plug-in with terminal block

Ordering source area code

Code	areas
-	Japan, Asia Australia
E	Europe
N	North America

Stations

02	2 stations
⋮	⋮
10	10 stations

Symbol

Symbol	Port specifications		Porting (A, B)
	P	EA, EB	
1	Common	Common	Side
2			Bottom*

* Option

Port size

Symbol	P, EA, EB	A, B
04		1/2
06	3/4	3/4
M		Mix

Thread

	Rc (PT)
N	NPT
T	NPTF
F	G (PF)

* Bottom ported: 1/2 only.

Plug-in: With Multi-connector

(Wiring specifications: Please refer to p.1.17-8.)

•Master connection of power and solenoid valves.
•Quick wiring permits easier installation.

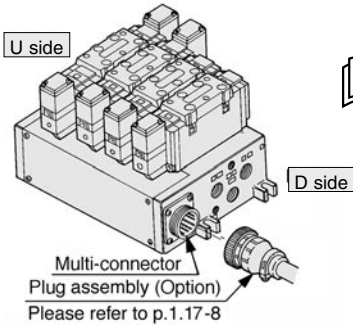

VV5FS5 - 01C D - 05 2 - 04 - Q

Series VFS5000 Manifold
Plug-in with multi-connector

Ordering source area code

Code	areas
-	Japan, Asia Australia
E	Europe
N	North America

Stations

02	2 stations
⋮	⋮
08	8 stations

* Max: 8 stations.

Symbol

Symbol	Port specifications		Porting (A, B)
	P	EA, EB	
1	Common	Common	Side
2			Bottom*

* Option

Port size

Symbol	P, EA, EB	A, B
04		1/2
06	3/4	3/4
M		Mix

Thread

	Rc (PT)
N	NPT
T	NPTF
F	G (PF)

* Bottom ported: 1/2 only.

Plug-in: With D-sub Connector

(Wiring specifications: Please refer to p.1.17-8.)

•Wide range of interchangeability (MIL Spec. DIN connector terminal 25 pcs attached.)
•Quick wiring permits easier installation.

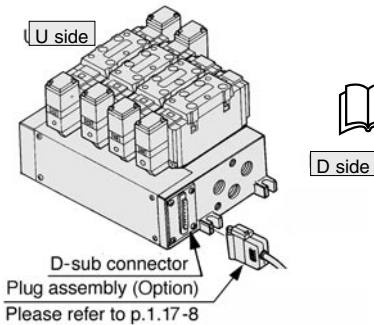

VV5FS5 - 01F D - 06 1 - 04 - Q

Series VFS5000 Manifold
Plug-in with D-sub connector

Ordering source area code

Code	areas
-	Japan, Asia Australia
E	Europe
N	North America

Stations

02	2 stations
⋮	⋮
08	8 stations

* Max: 8 stations.

Symbol

Symbol	Port specifications		Porting (A, B)
	P	EA, EB	
1	Common	Common	Side
2			Bottom*

* Option

Port size

Symbol	P, EA, EB	A, B
04		1/2
06	3/4	3/4
M		Mix

Thread

	Rc (PT)
N	NPT
T	NPTF
F	G (PF)

* Bottom ported: 1/2 only.

Non plug-in: DIN Connector

•Wiring for every valve.

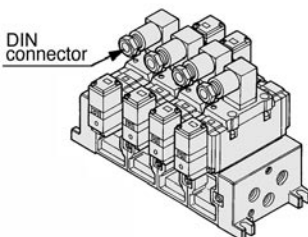

VV5FS5 - 10 - 05 2 - 04 - Q

Series VFS5000 Manifold
Non plug-in

Ordering source area code

Code	areas
-	Japan, Asia Australia
E	Europe
N	North America

Stations

02	2 stations
⋮	⋮
10	10 stations

Symbol

Symbol	Port specifications		Porting (A, B)
	P	EA, EB	
1	Common	Common	Side
2			Bottom*

* Option

Port size

Symbol	P, EA, EB	A, B
04		1/2
06	3/4	3/4
M		Mix

Thread

	Rc (PT)
N	NPT
T	NPTF
F	G (PF)

* Bottom ported: 1/2 only.

VFS5000

Manifold Specifications

Base style	Wiring	Porting	Port size		No. of stations	Applicable solenoid valve
		A, B port	P, EA, EB	A, B		
Plug-in VV5FS5-01□	<ul style="list-style-type: none"> •With terminal block •With multi-connector •With D-sub connector 	Side, Bottom	3/4	1/2 3/4	2 to 10*	VFS5□00-□F
Non plug-in VV5FS5-10	•DIN Connector					VFS5□10-□D

 * With multi connector, with D sub-connector: 8 stations at max.

Manifold Stations and Effective Area (mm²) (N/min)

Porting/No. of stations	First station	Fifth station	Tenth station
P→A or B	73.0 (3975)	73.0 (3975)	71.4 (3897)
A→EA, B→EB	88.2 (4809)	88.2 (4809)	88.2 (4809)

 * Port size: 1/2, 3/4

Manifold/Option Parts Assembly

Individual SUP spacer

An individual SUP spacer set on manifold block can form SUP port for every valve.

Body	Plug-in	Non plug-in
Part No.	VVFS5000-P-04-1	VVFS5000-P-04-2

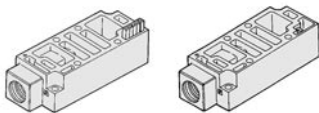

Individual EXH spacer

An individual EXH spacer set on manifold block can form EXH port for every valve.

Body	Plug-in	Non plug-in
Part No.	VVFS5000-R-04-1	VVFS5000-R-04-2

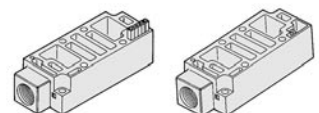

SUP block disk

When supplying manifold with more than two different pressures, high and low, insert a block plate in between stations subjected to different pressures.

Body	Plug-in	Non plug-in
Part No.	AXT628-12A	

EXH block disk

When valve exhaust affects the other stations on the circuit or when the reverse pressure valve is used to standard manifold valve, insert EXH block plate in between stations to separate valve exhaust.

Body	Plug-in	Non plug-in
Part No.	AXT512-14-1A	



EXH block disk



SUP block disk

Interface speed control

Needle valve set on the manifold block can control cylinder speed by throttling exhaust.

Body	Plug-in	Non plug-in
Part No.	VVFS5000-20A-1	VVFS5000-20A-2

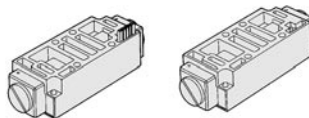

Double check spacer

The concurrent use of double check spacer with built-in double check valve can stop the cylinder at mid-position and hold for a long time without being affected by the air leakage across spool seals.

Body	Plug-in	Non plug-in
Part No.	VVFS5000-22A-1	VVFS5000-22A-2

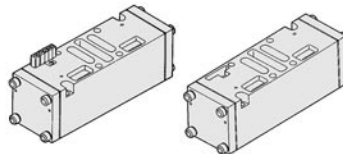

Interface regulator

 Interface regulator set on manifold block can regulate the pressure to each valve. Refer to p.1.17-6 for flow characteristic.

Body	Plug-in	Non plug-in
P regulation	ARBF5050-00-P-1	ARBF5050-00-P-2
A regulation	ARBF5050-00-A-1	ARBF5050-00-A-2
B regulation	ARBF5050-00-B-1	ARBF5050-00-B-2

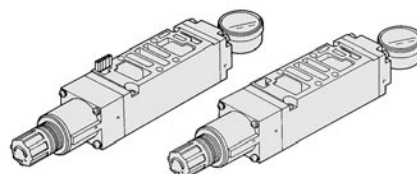

Blank plate

When disassembling valve for maintenance purposes or when spare manifold stations are required, install a blank plate on the manifold block.

Body	Plug-in	Non plug-in
Part No.	VVFS5000-10A	

How to Order Manifold

Please indicate manifold base mounting style, corresponding valve, and option parts.

<<Example>>

•Plug-in with terminal block –6 stations
(Manifold base) VV5FS5-01T-061-04-Q 1
(2 position single) VFS5100-5FZ-Q 3
(2 position double) VFS5200-5FZ-Q 2
(Blanking plate) VVFS5000-10A 1

•Non plug-in - 6 stations
(Manifold base) VV5FS5-10-061-04-Q 1
(2 position single) VFS5110-5D-Q 5
(3 position exhaust centre) VVFS5410-5D-Q1
(Individual EXH spacer) AXT628-9A-2 1

Manifold Options

With exhaust cleaner

Plug-in/Non plug-in

- Valve exhaust noise dampening: 35dB or more.
- Oil mist collection :
Rate of collection 99.9% or more.
- Piping process reduced.

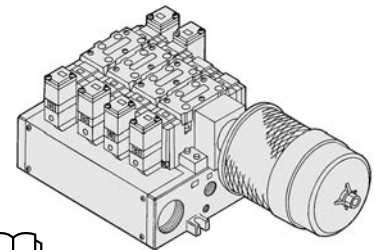

For more information, please refer to p.1.17-

With serial interface unit

Plug-in

- Solenoid valve wiring process reduced considerably.
- Disperse installation possible.
Manifold solenoid valve: 8 stations max,
32 positions (512 solenoids).
- Maintenance and inspection are easy.

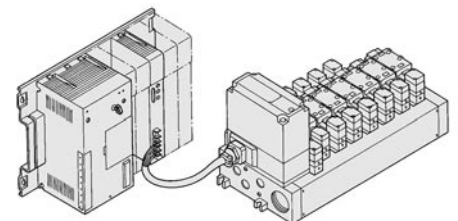

Manifold Plug-in/Non Plug-in

Plug-in (with terminal block): VV5FS5-01T- Station 1- Port size

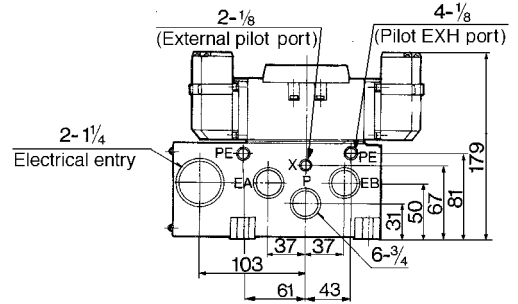

Bottom ported: VV5FS5-01T- Station 2- Port size

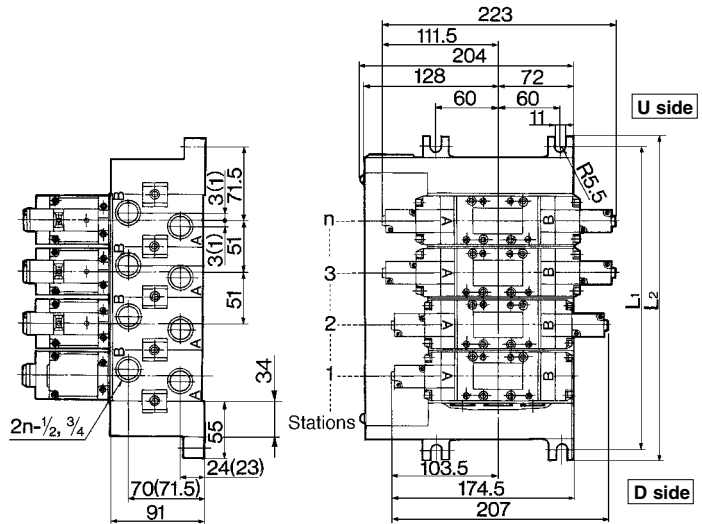
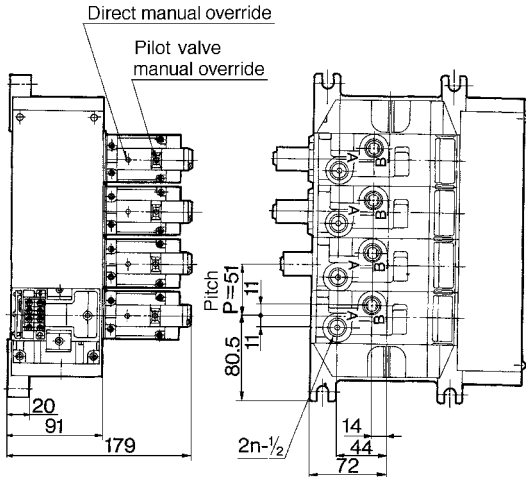

() : A/B port 3/4

General formula of weight/Manifold $M=0.911n+1.621$ (kg) n:

Non plug-in: VV5FS5-10- Station 1- Port size

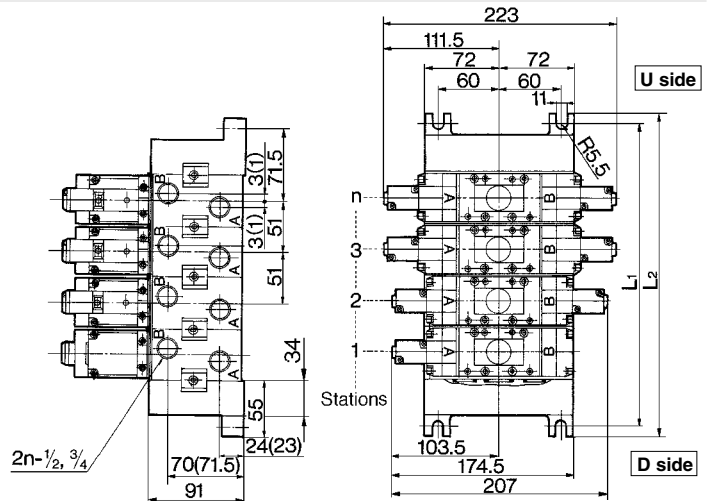
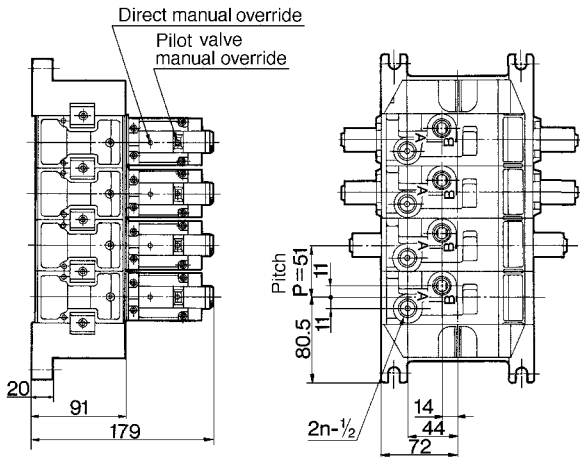

VV5FS5-10- Station 2- Port size DIN connector

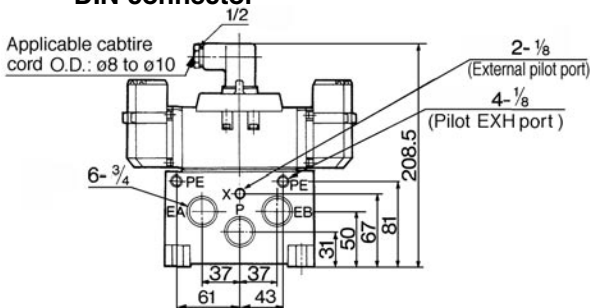

Grommet with terminal

General formula of weight/Manifold $M=0.811n+1.231$ (kg) n:

() : A/B port 3/4

L \ n	2	3	4	5	6	7	8	9	10	Equation
L1	194	245	296	347	398	449	500	551	602	$L1=51 \times n+92$
L2	212	263	314	365	416	467	518	569	620	$L2=51 \times n+110$

VFS5000

Plug-in with Multi-Connector/With D-Sub Connector

Plug-in with multi-connector: VV5FS5-01CD- Station 1- Port size, VV5FS5-01CU- Station 1- Port size

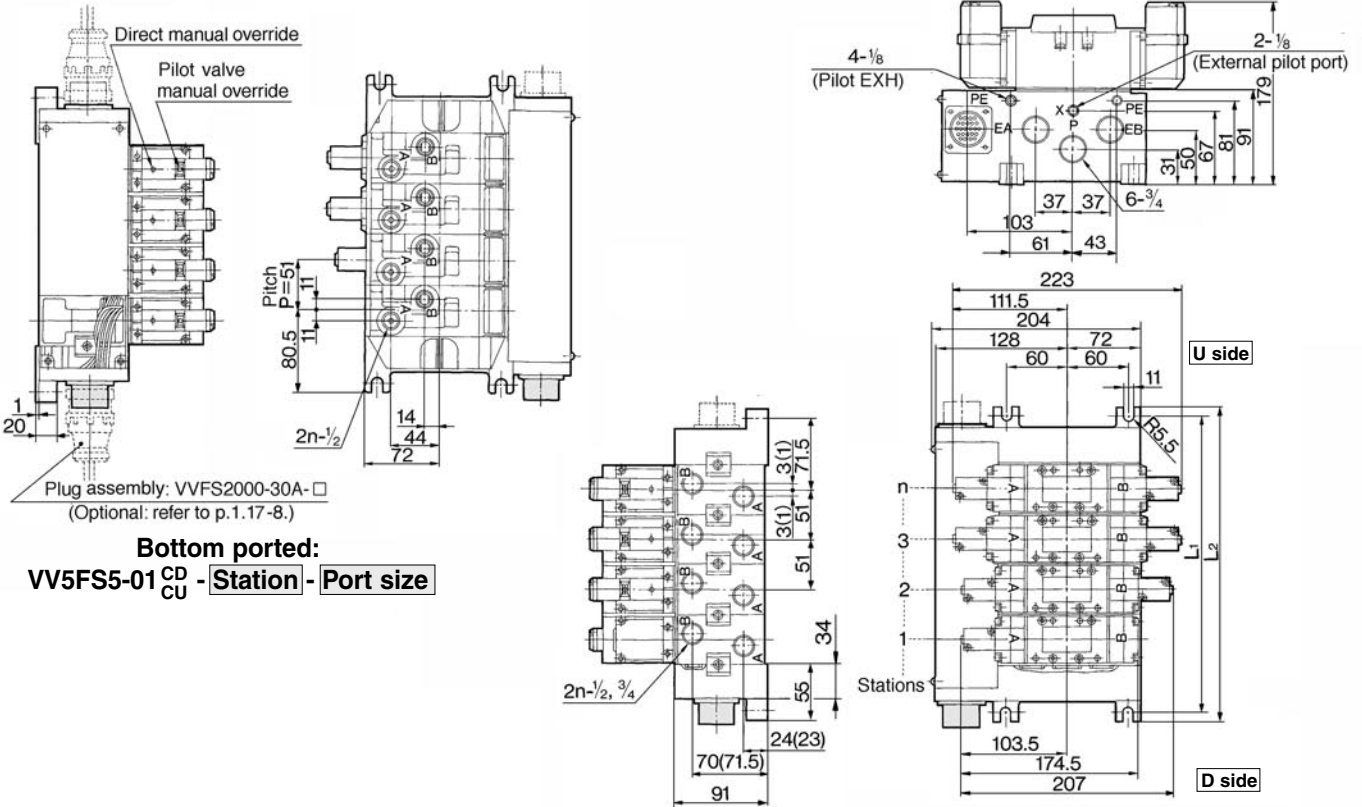

General formula of weight/Manifold $M=0.916n+1.709$ (kg) n:



(): A/B port 3/4

Plug-in with D-sub connector: VV5FS5-01FD- Station 1- Port size, VV5FS5-01FU- Station 1- Port size

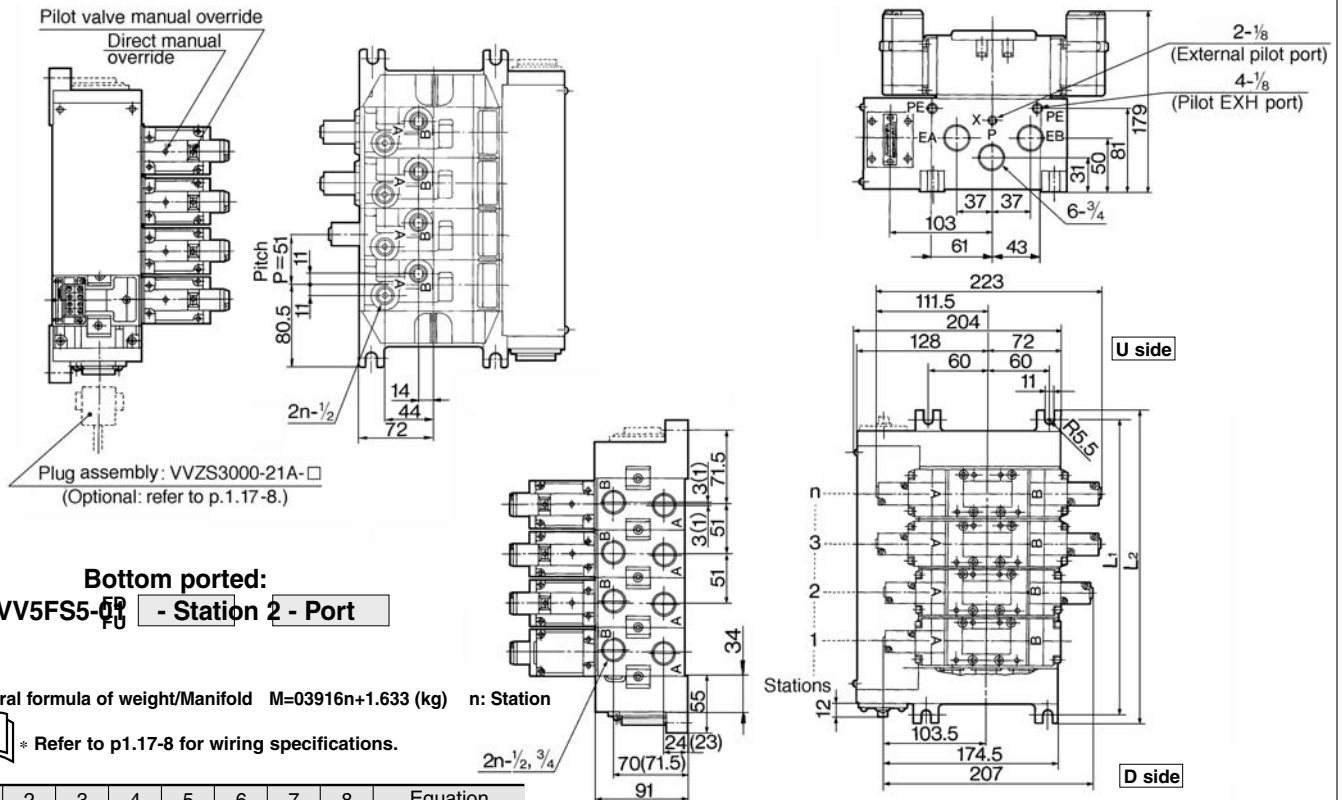

General formula of weight/Manifold $M=0.3916n+1.633$ (kg) n: Station



* Refer to p.1.17-8 for wiring specifications.



(): A/B port 3/4

L	n	2	3	4	5	6	7	8	Equation
L1		194	245	296	347	398	449	500	$L1=51 \times n + 92$
L2		212	263	314	365	416	467	518	$L2=51 \times n + 110$

Manifold with Exhaust Cleaner

- Serves to protect working environment.
- Valve exhaust noise dampening: **35dB or more.**
- Collection rate of drainage and oil mist: **99.9% or more.**
- Piping process reduced.

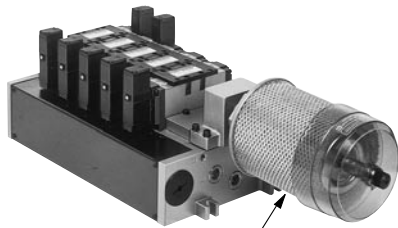

Plug-in
U side

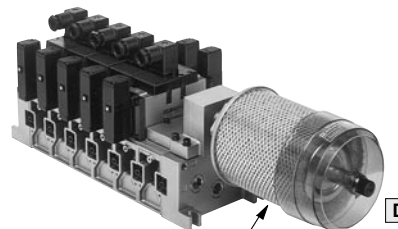

Non plug-in

Exhaust cleaner
(Optional)

Exhaust cleaner
(Optional)

Manifold Specifications

Manifold Model	Plug-in: VV5FS5-01 □	Non plug-in: VV5FS5-10
Wiring	With terminal block With multi-connector With D-sub connector	DIN connector Grommet terminal
Applicable valve	VFS5□□0-□F	VFS5□□10-□D, VFS5□□10-□E
Porting Rc (PT)	Common SUP, Common EXH	
	A, B port	Side: 1/2, 3/4, Bottom: 1/2 (Option)
	P, EA, EB port	P: 3/4, EXH: 1 1/2
No. of stations	2 to 10 ⁽¹⁾	
Applicable exhaust cleaner	AMC810-14 (Connecting port 1 1/2 Rc (PT)) ⁽²⁾	

Note 1) With multi connector, or with D-sub connector: 8 stations max.
Note 2) Exhaust cleaner: Not attached.

How to Order

VV5FS5-10-06-1-04-CD-Q

Series VFS5000 Manifold

Ordering source area code

Code	areas
-	Japan, Asia Australia
E	Europe
N	North America

Base style

01T	Plug-in with terminal block
01C	Plug-in with multi-connector
01F	Plug-in with D-sub connector
10	Non plug-in

Connector mounting direction

Symbol	With connector	Applicable base
-	None	01T, 10
D	D-side mounting	01C, 01F
U	U-side mounting	

Stations

02	2 stations
⋮	⋮
10	10 stations

Thread

-	Rc (PT)
N	NPT
T	NPTF
F	G (PF)

Port size

Symbol	P	A, B
04	3/4	1/2
06		3/4
M		Mix

* Bottom ported: Only 1/2

Exhaust cleaner mounting direction

Symbol	Exhaust cleaner mounting direction
CD	D side D side mounting
CU	U side U side mounting

Symbol

Symbol	Port specifications		Porting (A, B)
	P	EA, EB	
1	Common	Common	Side
2			Bottom*

* Option

Please indicate manifold base mounting style, corresponding valve, and option parts.

<<Example>> Plug-in with terminal block (6 stations)

(Manifold base)	VV5FS5-01T-061-04-CD-Q	1
(2 position single)	VFS5100-5FZ-Q	3
(2 position double)	VFS5200-5FZ-Q	2
(Blank plate)	VVFS5000-10A	1
(Exhaust cleaner)	AMC810-14	1

•Non plug-in (6 stations)

(Manifold base)	VV5FS5-10-061-04-CU-Q	1
(2 position single)	VFS5110-5D-Q	3
(2 position double)	VFS5210-5D-Q	2
(Blank plate)	VVFS5000-10A	1
(Exhaust cleaner)	AMC810-14	1

⚠ Precautions

When using exhaust cleaner, mount it downwards.

⚠ Protective class class I (Mark: )



* Refer to p.5.3-1 for Exhaust Cleaner details.

VFS5000

Manifold with Exhaust

Plug-in/Non Plug-in

Plug-in: VV5FS5-01T- Station 1- Port size $\begin{matrix} \text{CD} \\ \text{CU} \end{matrix}$

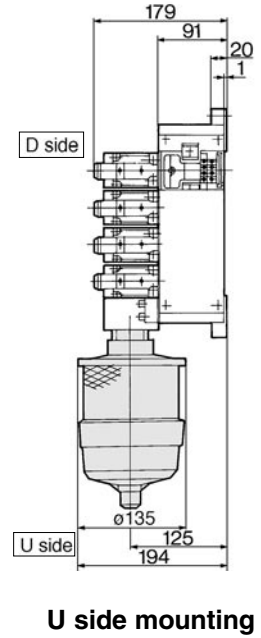
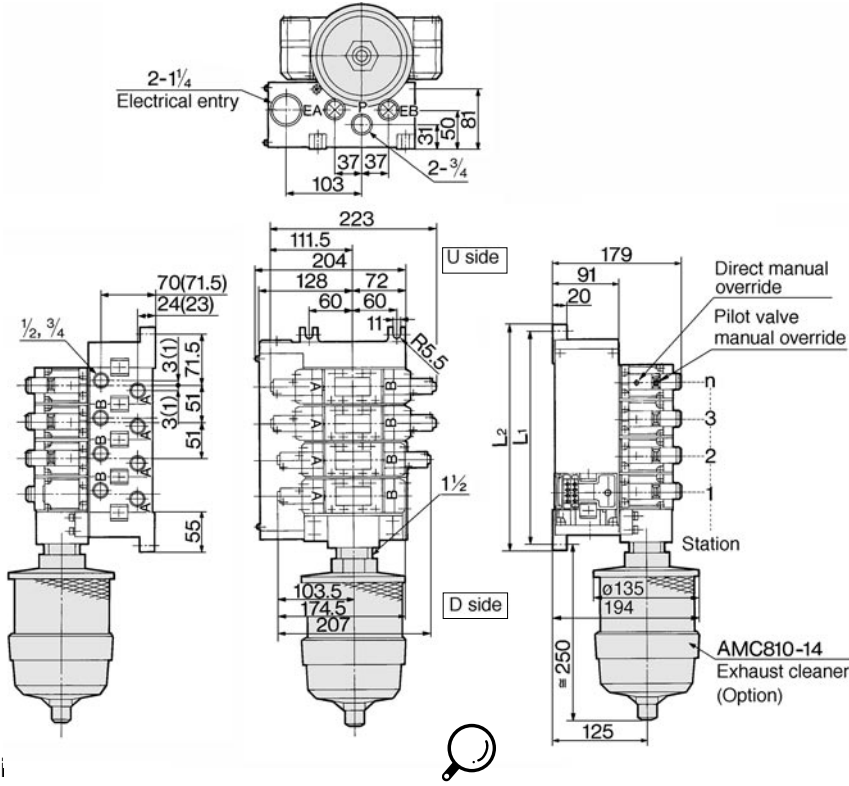

Non plug-in: VV5FS5-10- Station 1- Port size $\begin{matrix} \text{CD} \\ \text{CU} \end{matrix}$

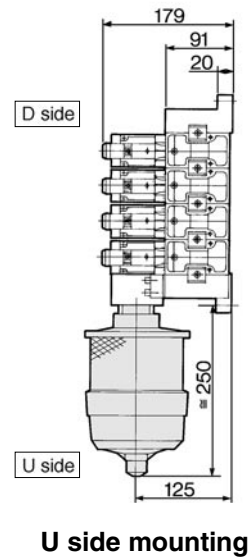
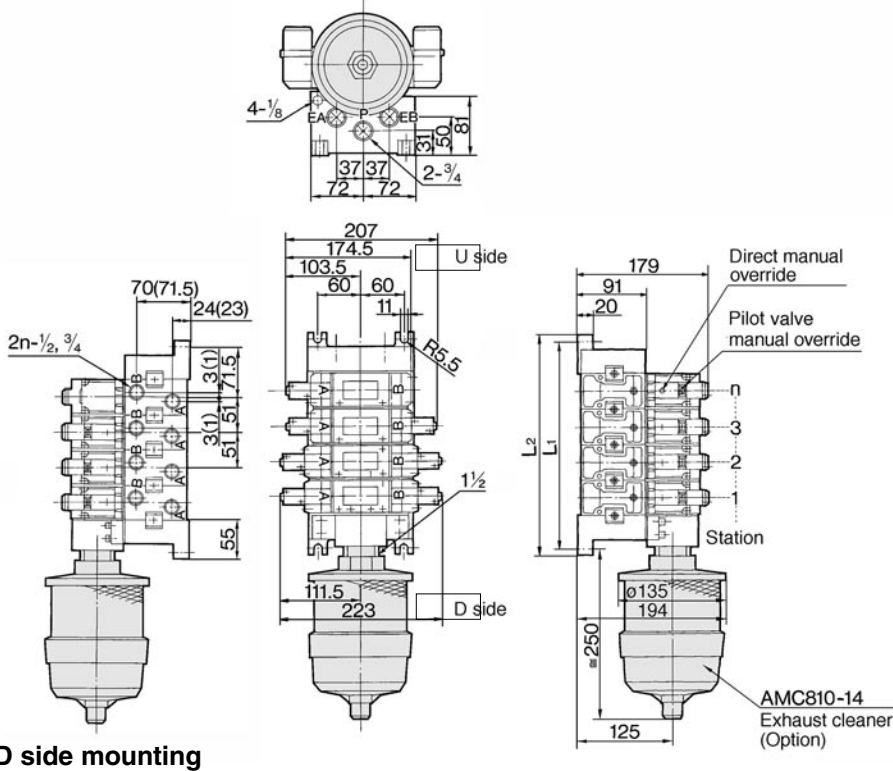

D side mounting

() : A/B port 3/4

		n: Station									
L	n	2	3	4	5	6	7	8	9	10	Equation
L ₁		194	245	296	347	398	449	500	551	602	L ₁ =51 X n+92
L ₂		212	263	314	365	416	467	518	569	620	L ₂ =51 X n+110

Manifold Option Parts Plug-in/Non Plug-in

Individual SUP spacer:
 VVFS5000-P-04-1 (Plug-in)
 VVFS5000-P-04-2 (Non plug-in)

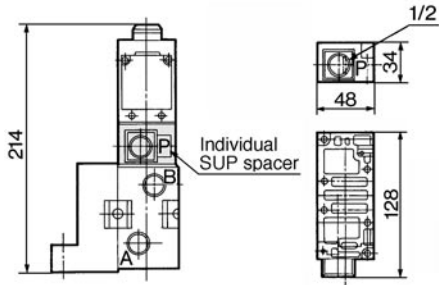

Double check spacer:
 VVFS5000-22A-1 (Plug-in)
 VVFS5000-22A-2 (Non plug-in)

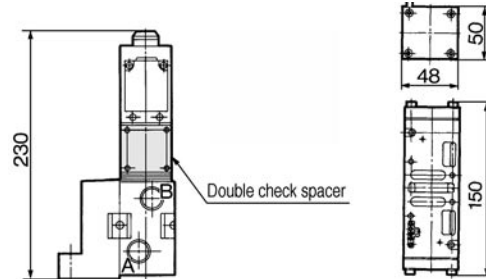

Individual EXH spacer:
 VVFS5000-R-04-1 (Plug-in)
 VVFS5000-R-04-2 (Non plug-in)

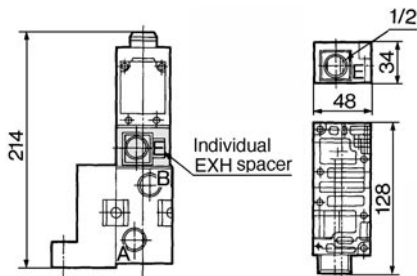

Interface regulator/P port regulation:
 ARBF5050-00-P-1 (Plug-in)
 ARBF5050-00-P-2 (Non plug-in)

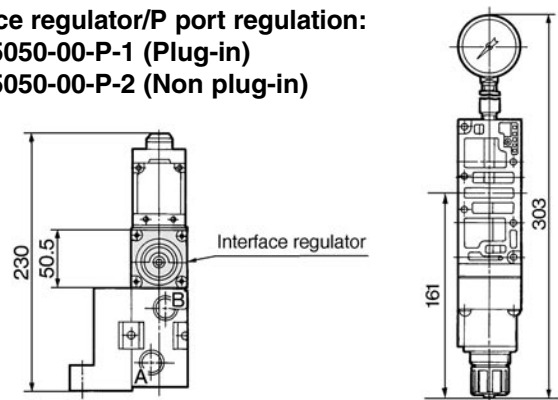

SUP block disk: AXT628-12A
EXH block disk: AXT512-14-1A

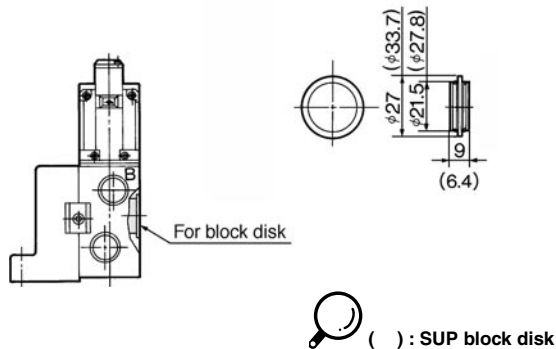

Interface regulator/A port regulation:
 ARBF5050-00-A-1 (Plug-in)
 ARBF5050-00-A-2 (Non plug-in)

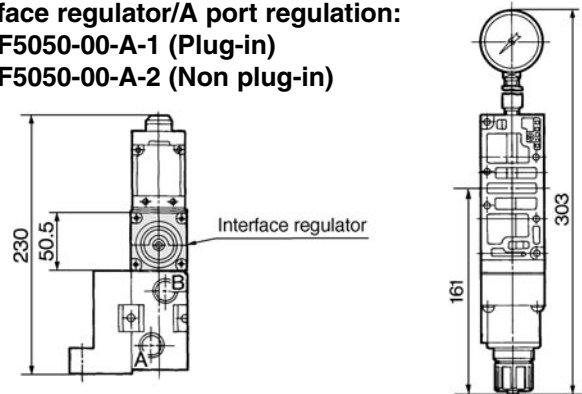

Interface speed control:
 VVFS5000-20A-1 (Plug-in)
 VVFS5000-20A-2 (Non plug-in)

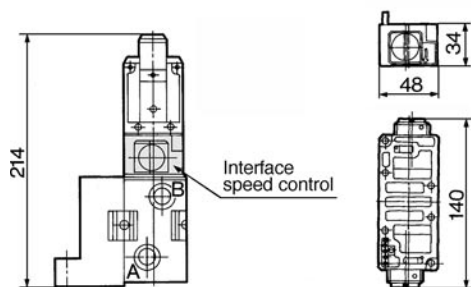

Interface regulator/B port regulation:
 ARBF5050-00-B-1 (Plug-in)
 ARBF5050-00-B-2 (Non plug-in)

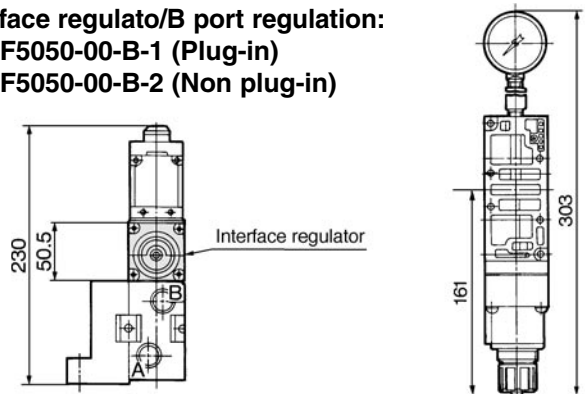

Manifold Base Construction Plug-in/Non Plug-in

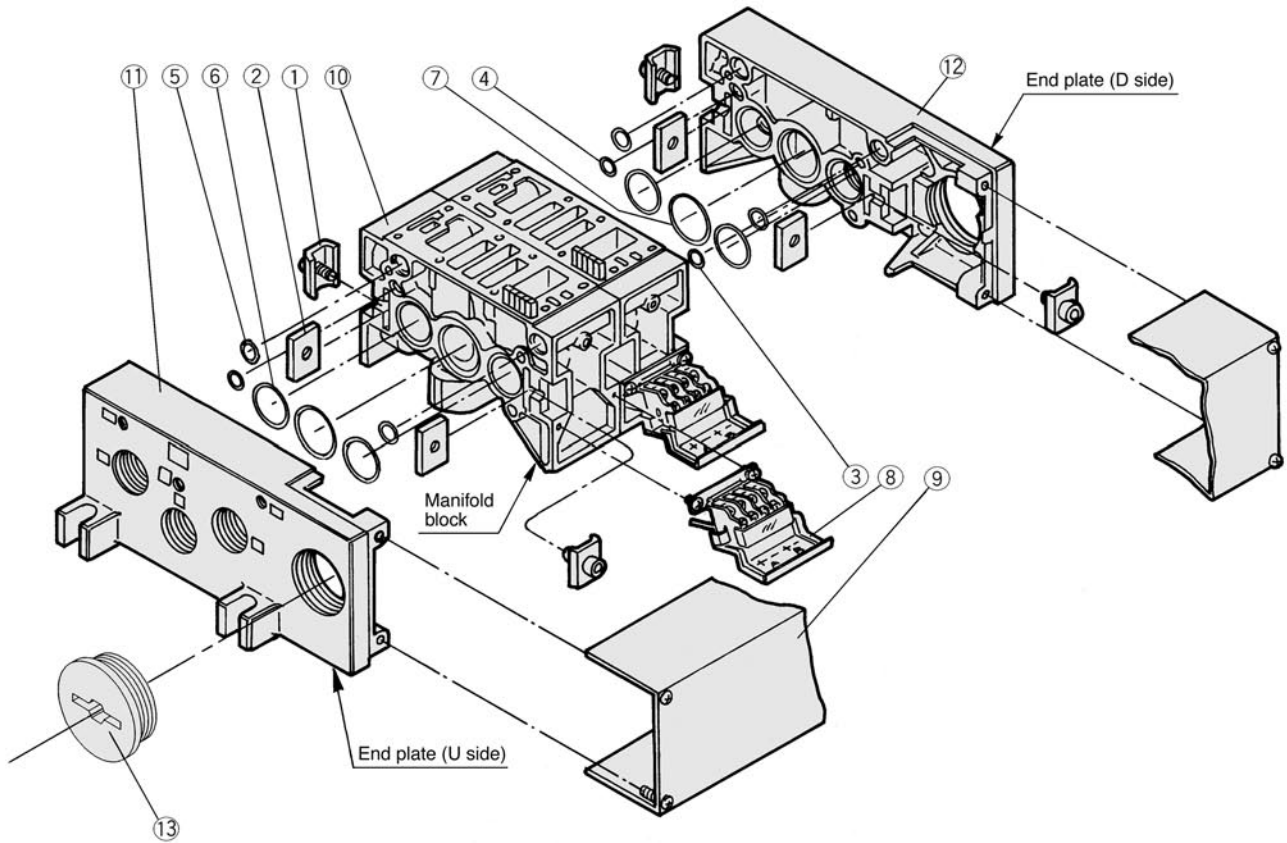

Replacement Parts

No.	Description	Material	Part No.
①	Metal joint A	Steel plate	AXT628-6-1A
②	Metal joint B	Steel plate	AXT628-6-2
③	O ring	NBR	AS568-006
④	O ring	NBR	AS568-010
⑤	O ring	NBR	AS568-013
⑥	O ring	NBR	AS568-022
⑦	O ring	NBR	AS568-026
⑧	Terminal assembly	—	AXT628-5-1A
⑨	Junction cover assembly	For 01T	VVFS5000-4A- <small>stations</small>
		For 01SU	AZ738-31A- <small>stations</small>
⑬	Rubber plug	NBR	AXT336-9

•For increasing the manifold bases, please order the manifold block assembly number of the principal part assembly ⑩. For plug-in: The manifold base with terminal stand (integrated with a junction cover) is required with the ⑨ junction cover assembly.

Replacement Parts Sub-assembly



Note) Manifold Base/Construction: Plug-in with terminal block.

No.	Description	Assembly part No.	Component parts	Applicable manifold base
⑩	Manifold block assembly	VVFS5000-1A-1- <small>04</small> / <small>06</small>	Manifold block ⑩, Metal joint ①, ②, Terminal ⑧, O ring ③, ④, ⑤, ⑥, ⑦, Receptacle assembly	Plug-in
		VVFS5000-1A-2- <small>04</small> / <small>06</small>	Manifold block ⑩, Metal joint ①, ②, O ring ③, ④, ⑤, ⑥, ⑦	Non plug-in
⑪	End plate (U side) assembly	VVFS5000-2A-1	End plate (U) ⑪, Metal joint ①, ②	Plug-in
		VVFS5000-2A-2	End plate (U) ⑪, Metal joint ①, ②	Non plug-in
⑫	End plate (D side) assembly	VVFS5000-3A-1	End plate (D) ⑫, Metal joint ①, ②, O ring ③, ④, ⑤, ⑥, ⑦	Plug-in
		VVFS5000-3A-2	End plate (D) ⑫, Metal joint ①, ②, O ring ③, ④, ⑤, ⑥, ⑦	Non plug-in

5 Port Pilot/Metal Seal

Plug-in/Non Plug-in

Series VFS6000

Large flow/1: Nl/min 9815
Low power consumption/
1.8W DC

Easy maintenance

2 styles of sub-plates: Plug-in and non plug-in



JIS Symbol

2 Position
Single



Double

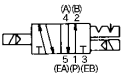

Model

Configuration	Model		Port size	Effective area (mm ²) (Nl/min)	Max. operating cycle (CPM) ⁽¹⁾	Response time (ms) ⁽²⁾	Weight (kg) ⁽³⁾	
	Plug-in	Non plug-in						
2 position	Single	VFS6100	VFS6110	3/4	162 (8833)	180	160 or less	2.5
				1	180 (9815)			
	Double	VFS6200	VFS6210	3/4	162 (8833)	180	60 or less	2.75
				1	180 (9815)			



Note 1) According to JIS B8375-1981 (once per 30 days) for the min. operating frequency.

Note 2) According to JIS B8375-1981. (The value at supply pressure 0.5MPa.)

Note 3) The figures in the above list are for without sub-plate. In case of with sub-plate, add 1.65kg for Rc3/4 and 1.5kg for RC 1 respectively.

Note 4) "Note 1)" and "Note 2)" are with controlled clean air.

Standard Specifications

Valve	Fluid		Air and inert gas
	Max. operating pressure		1.0MPa
	Min. operating pressure		0.1MPa
	Proof pressure		1.5MPa
	Ambient and fluid temperature		-10 to 60°C ⁽¹⁾
	Lubrication		Non-lube ⁽²⁾
	Pilot valve manual override		Non-locking push (Flush)
	Shock/vibration resistance		150/50m/s ² ⁽³⁾
Solenoid	Protection function		E type: Dust proof (0 class), F type: Drip proof (2 class), D type: Splash proof (4 class) ⁽⁴⁾
	Rated voltage		100V, 200V AC 50/60Hz, 24V DC
	Allowable voltage		-15% to +10% rated voltage
	Coil insulation		Class B or equivalent (130°C) ⁽⁵⁾
	Apparent power (Power consumption) AC	Inrush	5.6VA/50Hz, 5.0VA/60Hz
		Holding	3.4VA (2.1W)/50Hz, 2.3VA (1.5W)/60Hz
	Power consumption DC		1.8W
Electrical entry	Plug-in	Conduit terminal	
	Non plug-in	DIN terminal	



Note 1) Use dry-air at low temperatures

Note 2) Use turbine oil No.1 (ISO VG32), if lubricated.

Note 3) Shock resistance: No malfunction from test using drop impact tester to axis and right angle direction of main valve and armature, each one time when energized and de-energized.

Vibration resistance: No malfunction from test with 8.3 to 2000Hz 1 sweep, to axis and right angle directions of main valve and armature, each one when energized and de-energized. (Value in the initial stage.)

Note 4) According to JIS C0920. Note 5) According to JIS C4003.

Option Specifications

Pilot	External pilot ⁽¹⁾
Manual override Main valve	Direct manual override
Allowable voltage range	110 to 120V, 220V, 240V AC (50Hz/60Hz)
	12V, 100V DC
Piping	Bottom ported
Option	With indicator light and surge voltage suppressor, Non-rotating DIN terminal



Note 1) Operating pressure: 0 to 1.0MPa Pilot pressure ——— 0.1 to 1.0MPa

VFS6000

How to Order

Ordering source area code

Code	areas
-	Japan, Asia Australia
E	Europe
N	North America

Body

O: Plug-in sub-plate

Electrical entry

F: Plug-in conduit terminal

Piping port

	Side
-	Side
B*	Bottom

*In case of option or external pilot, bottom piping is not available.

Without sub-plate

	Without sub-plate
06	Rc (PT) 3/4
10	Rc (PT) 1

Thread

	Rc (PT)
N	NPT
T	NPTF
F	G (PF)

Plug-in VFS6 1 0 0 5 F Z 10 Q

Non plug-in VFS6 1 1 0 5 D Z 10 Q

Option

	None
Z	With indicator light and surge voltage suppressor

Configuration

1 2 position single

2 2 position double

Body

1: Non plug-in sub-plate

Electrical entry

D: DIN connector
DO: Without connector

Y: DIN connector (DIN 43650)
YO: Without DIN connector

Voltage

1	100V AC 50/60Hz
2	200V AC 50/60Hz
3	110 to 120V AC 50/60Hz
4	220V AC 50/60Hz
5	24V DC
6	12V DC
7	240V AC 50/60Hz
9	Other(250V or less)

Body option

0	Standard
1*	Direct manual override

* Option

Protective class class I (Mark:)

Pilot

-	Internal
R*	External

* Option

Contact SMC for other voltages (9)

How to Order Pilot Valve Assembly

SF4 - 1 F - 22 - Q

Voltage

1	100V AC 50/60Hz
2	200V AC 50/60Hz
3	110 to 120V AC 50/60Hz
4	220V AC 50/60Hz
5	24V DC
6	12V DC
7	240V AC 50/60Hz
9	Other (250 or less)

Contact SMC for other voltages (9)

* Refer to the p.1.17-5 for voltage conversion.

Maximum Cylinder Speed

Conditions: Supply pressure 0.5MPa, Load factor 50%

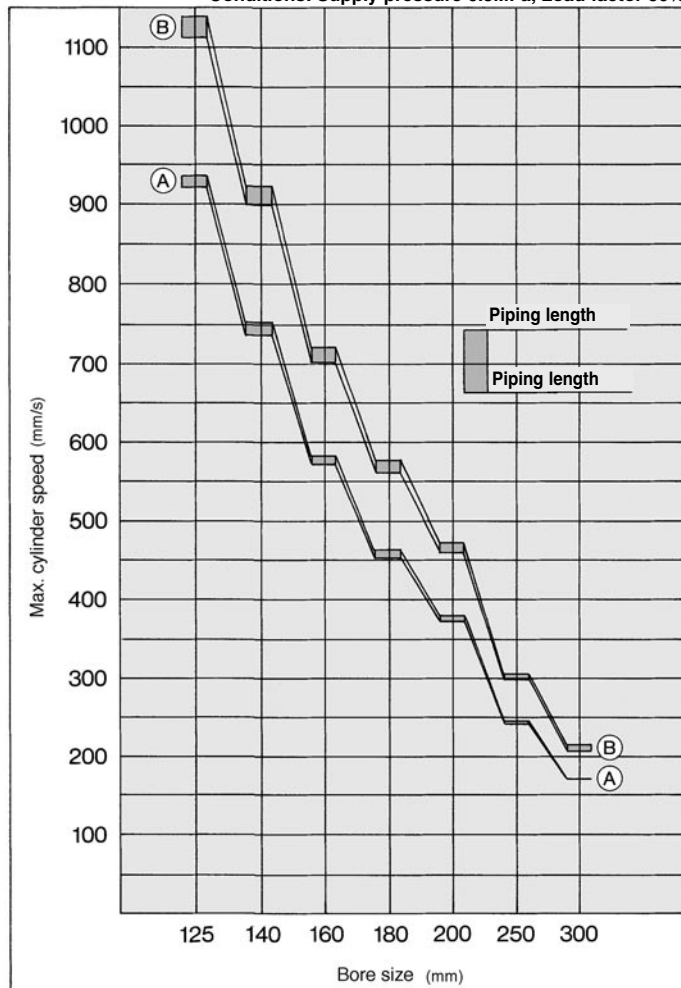

System diagram

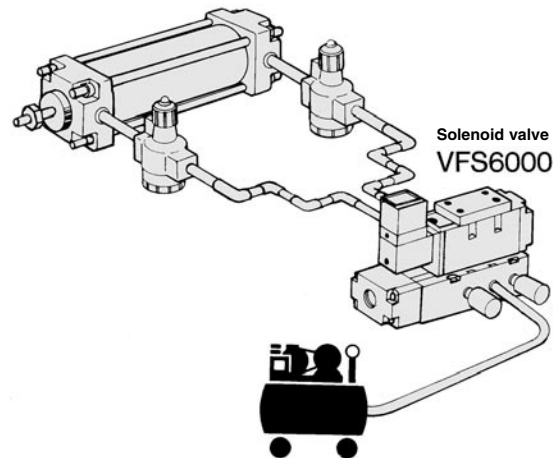

Rubber hose piping system

System	Solenoid valve	Speed controller	Silencer	Piping (Hose bore size)
A	VFS6000-10 {1} (S=180mm ²)	AS600-10 {1} (S=230mm ²)	AN600-10 {1} (S=270mm ²)	1 ^B (Fitting 4 pcs)

Steel piping system

System	Solenoid valve	Speed controller	Silencer	Piping (Hose bore size)
B	VFS6000-10 {1} (S=180mm ²)	AS600-10 {1} (S=230mm ²)	AN600-10 {1} (S=270mm ²)	1 ^B (Fitting 4 pcs)

Construction

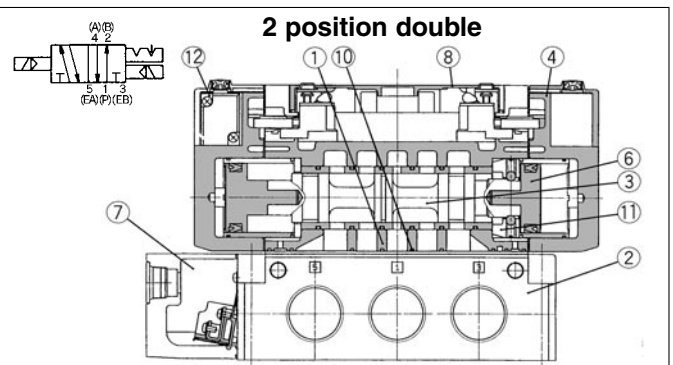
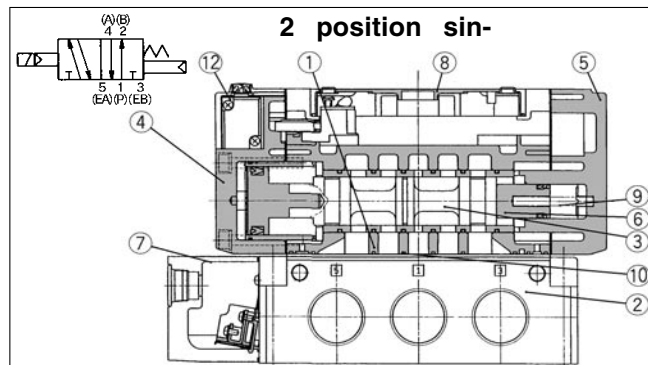

Component Parts

No.	Description	Material	Note
①	Body	Aluminium die-cast	Platinum silver
②	Sub-plate	Aluminium die-cast	Platinum silver
③	Spool/Sleeve	Stainless steel	
④	Adapter plate	Aluminium die-cast	Black
⑤	End plate	Aluminium die-cast	Black
⑥	Piston	Resin	
⑦	Junction cover	Resin	
⑧	Light cover	Resin	

Replacement Parts

No.	Description	Material	Part No.	
			VFS61□□	VFS62□□
⑨	Return spring	Stainless steel	VFS6000-16-3	—
⑩	Gasket	NBR	VFS6000-15	VFS6000-15
⑪	Detent assembly	—	—	VFS6000-8A
⑫	Pilot valve assembly	—	Refer to the p.1.17-100 "How to Order Pilot valve assembly".	

Sub-plate Assembly

Plug-in	VFS6000-P- ⁰⁶ / ₁₀
Non plug-in	VFS6000-S- ⁰⁶ / ₁₀

Mounting bolt and gasket are not included.

VFS6000

Plug-In 2 Position Single/Double

2 position single: VFS6100-□F

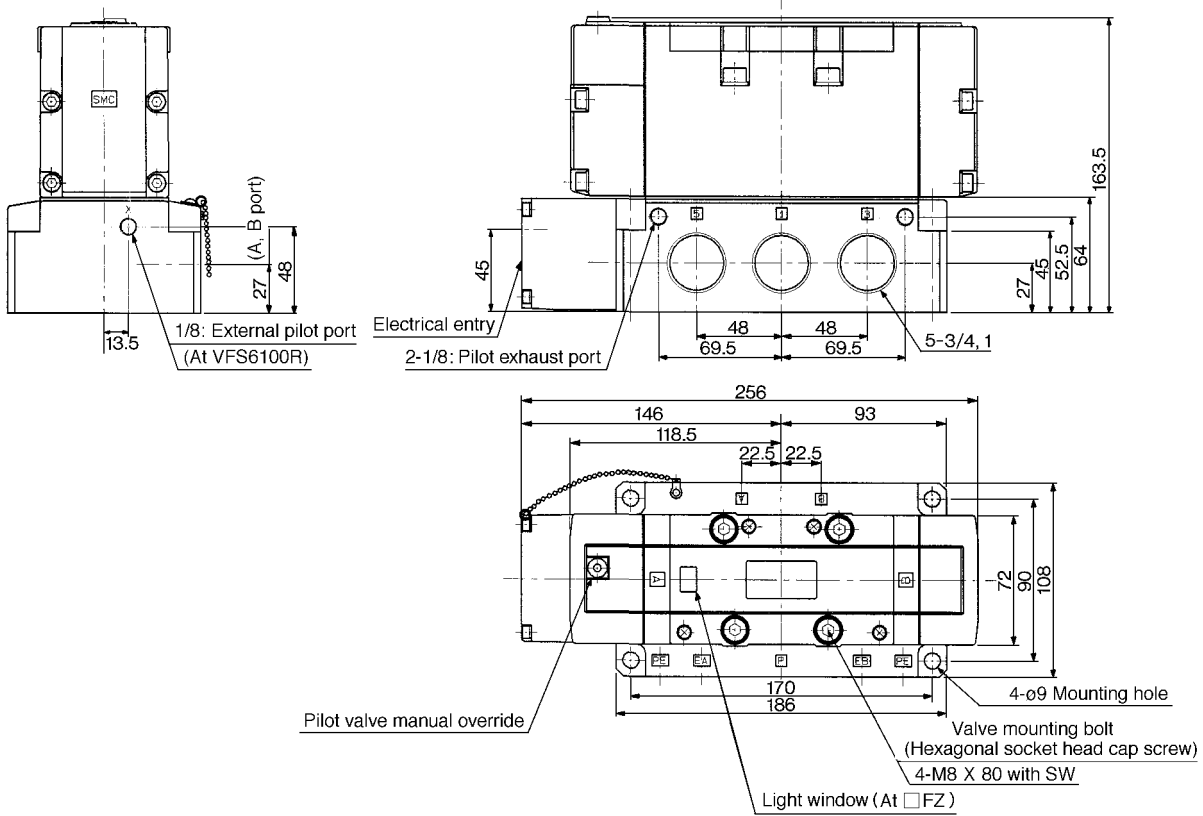

2 position double: VFS6200-□F

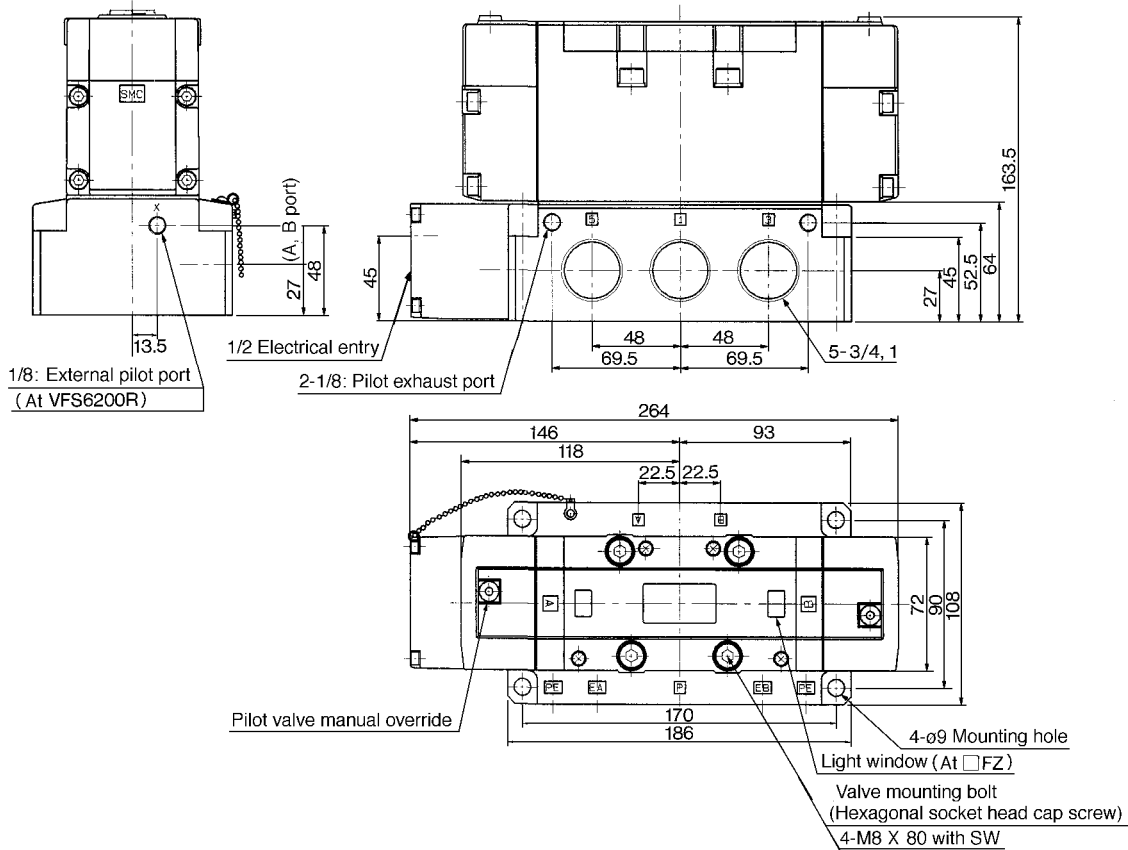

Non Plug- 2 Position Single/Double

2 position single: VFS6110-□D

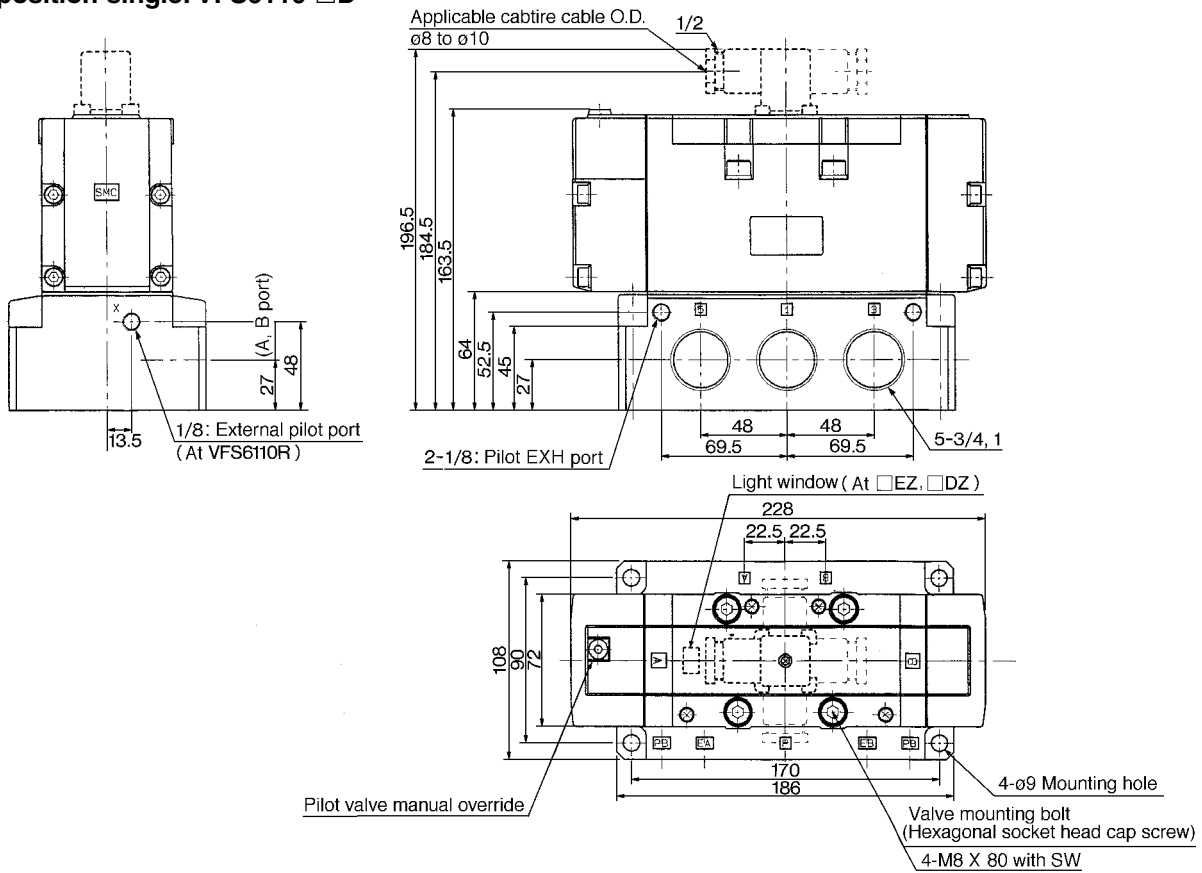

2 position double: VFS6210-□D

