

RoHS compliant

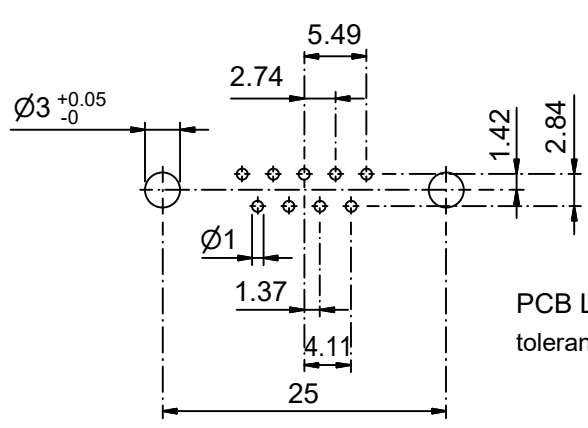
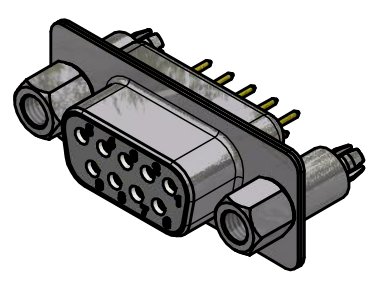
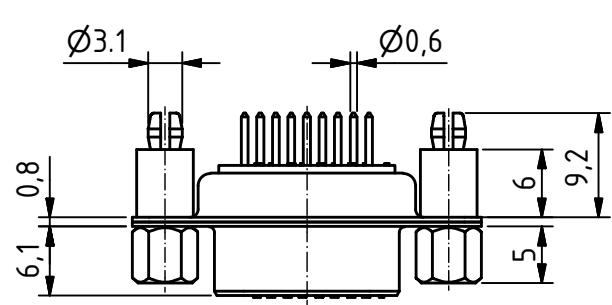
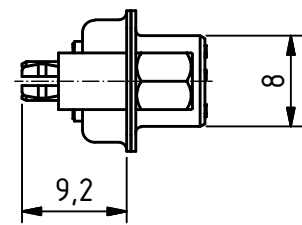
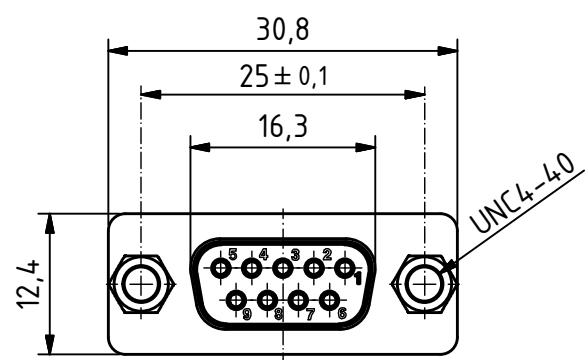

PCB Layout
tolerances +/-0.1

Product is
suitable for
Wave Solder
Process

General tolerances (Delttron standard)	
size in mm	
> 0.5	> 30
up to 3	up to 120
up to 6	up to 30
up to 30	up to 6
tolerances	
±0.1	±0.2
±0.2	±0.3

MATERIALS

- Insulator: Thermoplastic UL 94-V-0 white
- Contact: Machined / Copper alloy
- Contact finish: Quality class 2
- Shell: steel tin plated

CHARAKTERISTICS

- Working voltage: 125V
- Current rating: 7.5A
- Contact resistance: max. 10mΩ - DIN41652
- Insulation resistance: >5GΩ
- Temperature range: -55° to +125°C

	All dimensions in mm	Rev.	Rev.	Rev.	DE002382		
		Rev.	Rev.	Rev.	part no.		
DTS09SY/2M86UNB5				1.5:1 scale	drawn	02.11.2009	nf
					checked		
				approved			
				Industrie Neuhof 8c CH-3422 Kirchberg www.d-sub.swiss		K060493 drawing no.	