

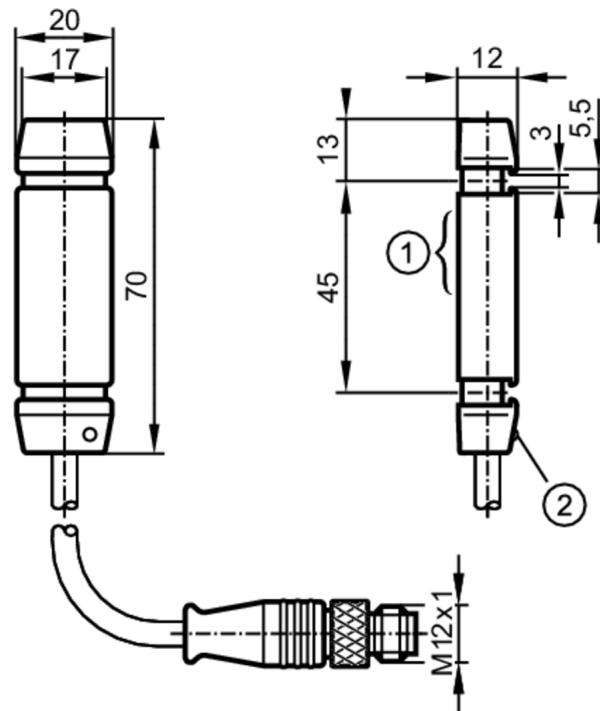

## Inductive tube sensor

I8-3014-ANKG/0,09M/US-100-DNS



- 1 Sensing face  
2 LED operating status



### Product characteristics

Electrical design	NPN
Output function	normally open
Sensing range [mm]	< 14
Housing	rectangular
Dimensions [mm]	70 x 20 x 12

### Application

Operating principle	static
---------------------	--------

### Electrical data

Operating voltage [V]	10...35 DC
Current consumption [mA]	< 15
Protection class	III
Reverse polarity protection	yes

### Outputs

Electrical design	NPN
Output function	normally open
Max. voltage drop switching output DC [V]	2
Permanent current rating of switching output DC [mA]	200
Short-circuit protection	yes
Overload protection	yes

# I85003



## Inductive tube sensor

I8-3014-ANKG/0,09M/US-100-DNS

Detection zone		
Sensing range	[mm]	< 14
Resolution of steel ball (diameter)	[mm]	3
Max. part speed	[m/s]	35
Response times		
Pulse stretching	[ms]	100
Max. fall time	[ms]	100
Response time	[ms]	< 0.5
Operating conditions		
Ambient temperature	[°C]	-25...70
Protection		IP 67
Tests / approvals		
MTTF	[years]	1323
UL approval	Ta	-25...70 °C
	Enclosure type	Type 4X (indoor use only) / 12 and 13
	voltage supply	Class 2
	File number UL	E174191
Mechanical data		
Weight	[g]	59.5
Housing		rectangular
Dimensions	[mm]	70 x 20 x 12
Materials		housing: PC
Displays / operating elements		
Display	switching status	1 x LED, yellow
	operation	1 x LED, green
Accessories		
Accessories (supplied)		fixing straps: 2
Remarks		
Pack quantity		1 pcs.
Electrical connection - plug		
Cable: 0.09 m, PUR		
Connector: 1 x M12		

# I85003



## Inductive tube sensor

I8-3014-ANKG/0,09M/US-100-DNS

### Connection

