

- 1
- 2
- 3
- 4
- 5
- 6
- 7
- 8
- 9
- 10
- 11
- 12
- 13
- 14
- 15
- 16
- 17
- 18

MATERIAL

Zinc-plated steel.

BALL AND SPRING

Stainless steel.

FEATURES AND APPLICATIONS

GN 506 dowels for T-slots with guide are suitable for use on aluminium sections. The device provided with a ball and spring and located inside the dowel allows it to slide avoiding accidental vertical slipping. These dowels are highly recommended for use with fixing hinges for aluminium sections type CFG. (see page 1360).



Application example

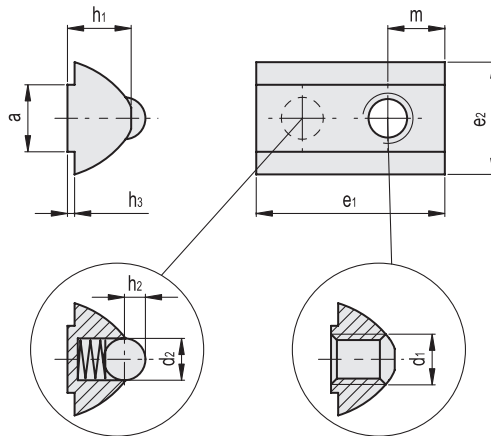
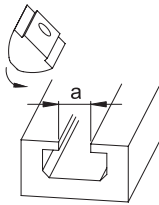

Code	Description	a	d1	d2	e1	e2	h1	h2	h3	m	Width a	⚖️
GN.24401	GN 506-5-M3	5	M3	3	12	7.7	4.5	0.7	0.6	4	5	2
GN.24402	GN 506-5-M4	5	M4	3	12	7.7	4.5	0.7	0.6	4	5	2
GN.24403	GN 506-5-M5	5	M5	3	12	7.7	4.5	0.7	0.6	4	5	2
GN.24405	GN 506-6-M3	6	M3	3.5	17	10.5	6.8	0.5	0.8	5	6	6
GN.24406	GN 506-6-M4	6	M4	3.5	17	10.5	6.8	0.5	0.8	5	6	5
GN.24407	GN 506-6-M5	6	M5	3.5	17	10.5	6.8	0.5	0.8	5	6	5
GN.24408	GN 506-6-M6	6	M6	3.5	17	10.5	6.8	0.5	0.8	5	6	5
GN.24411	GN 506-8-M4	8	M4	5	22	13.4	7.6	1.7	0.85	6.8	8	11
GN.24412	GN 506-8-M5	8	M5	5	22	13.4	7.6	1.7	0.85	6.8	8	11
GN.24413	GN 506-8-M6	8	M6	5	22	13.4	7.6	1.7	0.85	6.8	8	10
GN.24414	GN 506-8-M8	8	M8	5	22	13.4	7.6	1.7	0.85	6.8	8	9