

E10210

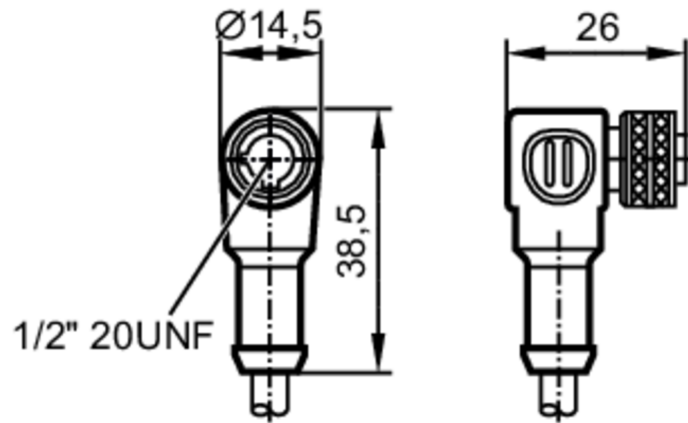

Connecting cable with socket

ADOAA030MSS0005H03



Application		
Special feature	Halogen-free; Drag chain suitability	
Electrical data		
Operating voltage [V]	< 250 AC / < 300 DC	
Operating conditions		
Ambient temperature [°C]	-25...90	
Protection	IP 67	
Mechanical data		
Weight [g]	204.8	
Dimensions [mm]	26 x 14.5 x 38.5	
Materials	TPU black	
Material nut	brass, nickel-plated	
Drag chain suitability	yes	
Drag chain suitability	bending radius for flexible use	min. 10 x cable diameter
	travel speed	max. 3.3 m/s for a horizontal travel length of 5 m and max. acceleration of 5 m/s ²
	bending cycles	> 2 Mio.
	torsional strain	± 180 °/m
Remarks		
Pack quantity	1 pcs.	

E10210



Connecting cable with socket

ADOAA030MSS0005H03

Electrical connection

Cable: 5 m, PUR, Halogen-free, black, \varnothing 5.2 mm; 3 x 0.5 mm² (64 x \varnothing 0.1 mm)

Electrical connection - socket

Connector: 1 x 1/2", angled; Moulded body: TPU; Locking: brass, nickel-plated

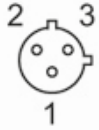

Connection

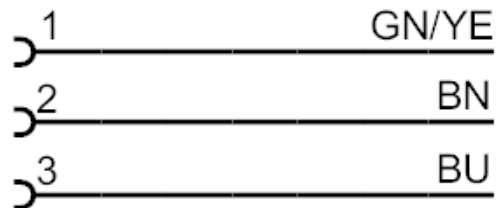

Core colours :

BN = brown

BU = blue

GN/YE = green/yellow