

# Low inertia dc servo motor

# M66 series

The M66CE is a high performance low inertia dc servo motor, providing up to 30W output power and offers smooth operation over a wide speed range. The M66CE motor incorporates a skewed ironless rotor thereby ensuring linear speed and torque characteristic combined with rapid acceleration and reversal capabilities.

The type M66CT includes an integral dc tachogenerator for optimum velocity control using analogue control techniques while M66CI series is provided with an integral dual track incremental encoder for use with digital control circuits.



## Dimensions: mm

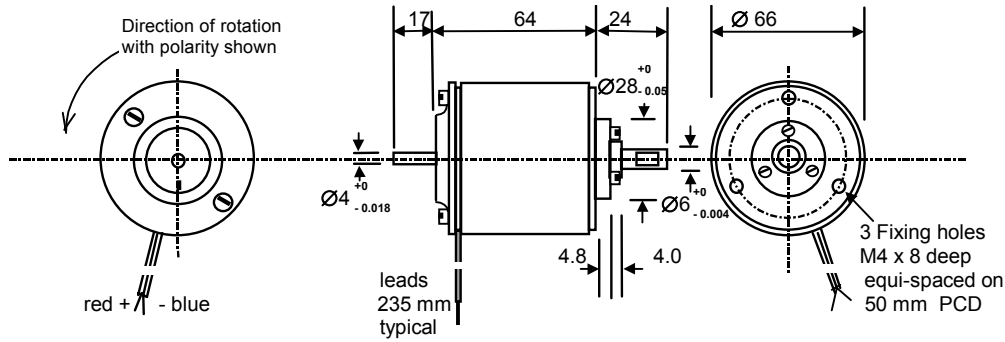

**Servo motor M66CE**

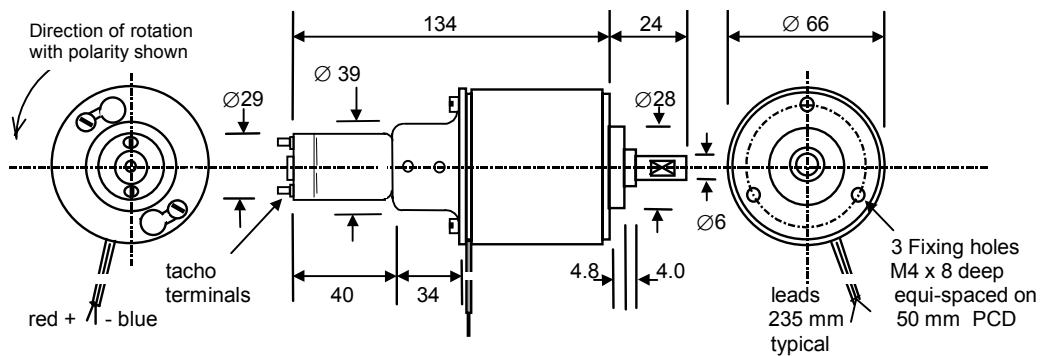

**motor-tacho M66CT**

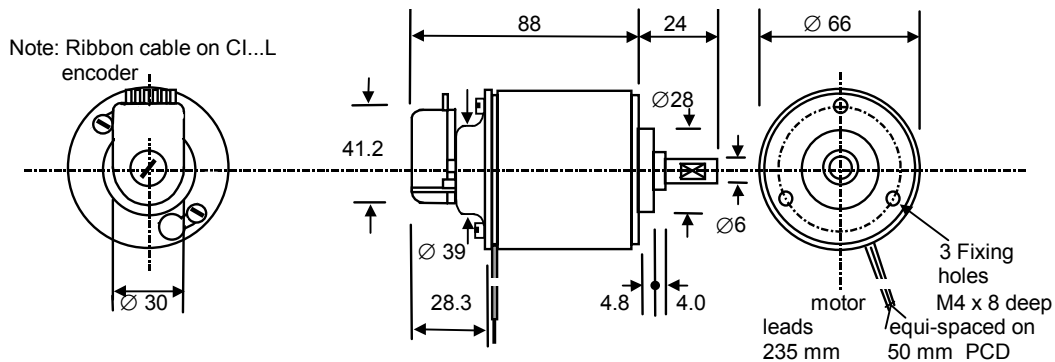

**motor-encoder M66CI**

## Typical

### performance

Motor	No-load Speed (rpm)	Rated Speed (rpm)	Rated Torque (Ncm)	Rated Current (Amps)	Peak Torque (Ncm)	using Servo Amplifier	DC Supply (Vdc)	Power Supply for AC operation (110-240 Vac)
<b>M66-12 series</b>	2,700	1,700	8	2.0	16	<b>MSE421</b>	12	suitable for use with 12 Vdc battery
<b>M66 -24 series</b>	2,300	1,600	9	1.0	27	<b>PM121-10*</b>	N/A	integral in amplifier
	2,300	1,600	9	1.0	27	<b>MSE421-30</b>	24	MSE 171E
	2,300	1,600	12	1.3	27	<b>MSE421-60</b>	24	MSE 171E

Note\* Specify PM121-10T when using matched M66 C24T3/T6-tacho unit



# 30 Watt Ironless rotor dc servo motor

# M66 series

## Specification dc servo motor type M66CE

M66 Motor- options:	M66CE-	-12	-24	Performance @ 24 Vdc
Nominal Voltage ( Vdc )		12	30	24
Maximum Output Power ( Watts)		15	30	20
No-load speed ( rpm )		2,700	2,900	2,300
Speed @ rated torque ( rpm )		1,800	2,300	1,600
Rated Torque ( Ncm )		8	12	12
Peak Torque ( Ncm )		25	36	27
Max. No load current (milli Amps )		120	65	60
Rotor Inertia ( Kgcm <sup>2</sup> )		0.214	0.214	
Mechanical time constant ( milli secs)		24.5	17	
Torque Constant ( Ncm / A )		4.1	9.8	
Voltage Constant ( V / 1000 rpm)		4.27	10.3	
Rotor Resistance ( Ohms )		1.9	7.8	
Rotor inductance ( mH )		1.0	5.0	
Commutation		copper -graphite		
Bearings		pre-loaded ball		
Maximum radial load		100 N, 12 mm from bearing face		
Maximum axial load		15 N		
Ambient operating temperature range		-10 to +60 ° C		

## motor-tacho versions M66CT series

types:		M66C12 T3	M66C24 T3	M66C24 T6
Nominal Voltage		12Vdc	24-30 Vdc	24-30 Vdc
Motor specification:		As above		
<b>Tacho Specification</b>		<b>T.3 series</b>	<b>T.6 series</b>	
Voltage constant	V/1000 rpm	3.25	6.50	
Average ripple	peak / peak	3% ( ripple frequency 18 cycles per rev.)		
Rotor resistance	Ohms	12	47	
Max. continuous speed	rpm	3,000		

## motor-encoder version M66-CI...series

types:		M66CI ...T-12	M66CI ...T-24
		M66CI ...L-12	M66CI ...L-24
Nominal Voltage		12Vdc	24Vdc
Motor specification:		As above	
<b>Encoder type</b>		<b>CI...T</b>	<b>CI...L</b>
Supply	Vdc	5 + 0.5	5 + 0.5
Max. Output signal	Vdc	5	5
Signal wave form		Square	Square
Output Circuit		TTL	RS 422
Output Configuration		Dual Track Quadrature	Dual Track + Index ( complementary )
Number of Lines		100 or 500	100 or 500

Typical Motor-encoder part number: **M66 CI 500 L-24**

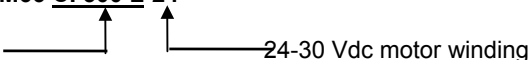
500 line dual track encoder with Index  24-30 Vdc motor winding

### Note:

M66 servo motors are also available with an integral parking brake ( M66DB )

If a parking brake is required please contact us for full specification of M66DB options

# dc servo motor with parking brake

# M66DB series

The M66DB is a low inertia, ironless rotor dc servo motor which is equipped with a 'power-off' parking brake to provide a static holding torque to resist movement under unbalanced load conditions when the motor/brake assembly is de-energised. Additionally the brake may be used in dynamic conditions to arrest motion although increased wear will then occur.

When the brake is energised the motor is free to rotate and may be controlled to provide a very wide speed range with minimal cogging, even at low speed, due to it's ironless rotor construction.

The motor is equipped with long-life carbon brushes which are suitable for electronic speed control by either linear or PWM servo amplifier systems.

## Dimensions: mm.

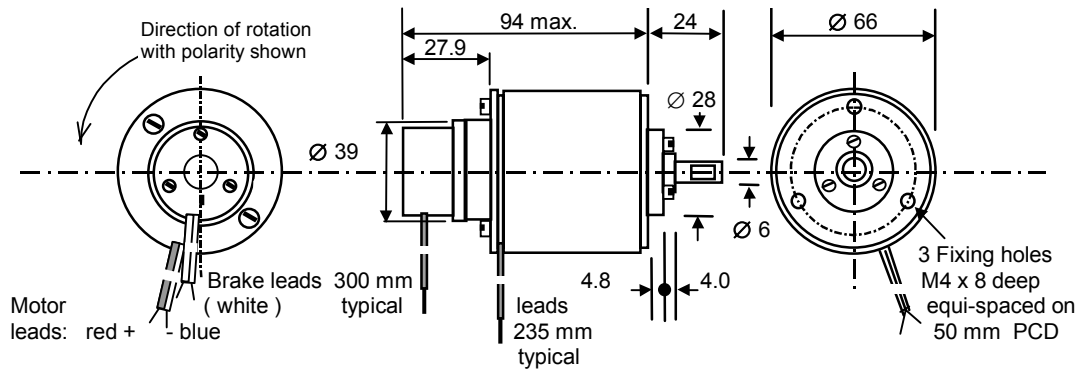

## Specification:

M66 Motor- Brake options: M66DB-	-12	-24	Performance @ 24 Vdc
Nominal Voltage ( Vdc )	12	30	24
Maximum Output Power ( Watts)	15	30	20
No-load speed ( rpm )	2,700	2,900	2,300
Speed @ rated torque ( rpm )	1,800	2,300	1,600
Rated Torque ( Ncm )	8	12	12
Peak Torque ( Ncm )	25	36	27
Max. No load current ( milli Amps )	120	65	60
Rotor Inertia ( Kgcm <sup>2</sup> )	0.214	0.214	
Mechanical time constant ( milli secs)	24.5	17	
Torque Constant ( Ncm / A )	4.1	9.8	
Voltage Constant ( V / 1000 rpm)	4.27	10.3	
Rotor Resistance ( Ohms )	1.9	7.8	
Rotor inductance ( mH )	1.0	5.0	
Commutation	copper -graphite		
Bearings	pre-loaded ball		
Maximum radial load	100 N, 12 mm from bearing face		
Maximum axial load	15 N		
Ambient operating temperature range	-10 to +60 °C		

## Brake specification

Nominal Operating Voltage ( Vdc )	12		24
Operating Current ( Amps )	≤ 0.50		0.22
Min. Pull-in voltage ( Vdc )	≤ 10		18
Max. Drop-out voltage ( Vdc )	≥ 6		8
Holding Torque, de-energised ( Ncm )	10		10

## Assembly order code

Standard voltage options	M66DB-12	M66DB-24
--------------------------	----------	----------

**Special Versions:**

In some cases it may be preferred to utilise a 24 Vdc version of the servo motor with 12 Volt rated brake and visa versa.

In these case the following special part numbers should be used:

**Specification: Special models**

Special models:	M66CE-12/ DB24	M66CE-24 /DB12
Nominal Motor Voltage	12 Vdc	24 Vdc
Nominal Brake Voltage	24 Vdc	12 Vdc
<b>Specification</b>		
Applied motor Voltage ( Vdc )	12	30      24
Maximum Output Power ( Watts)	15	30      20
No-load speed ( rpm )	2,700	2,900      2,300
Speed @ rated torque ( rpm )	1,800	2,300      1,600
Rated Torque ( Ncm )	8	12      12
Peak Torque ( Ncm )	25	36      27
Max. No load current (milli Amps )	120	65      60
Rotor Inertia ( Kgcm <sup>2</sup> )	0.214	0.214
Mechanical time constant ( milli secs)	24.5	17
Torque Constant ( Ncm / A )	4.1	9.8
Voltage Constant ( V / 1000 rpm)	4.27	10.3
Rotor Resistance ( Ohms )	1.9	7.8
Rotor inductance ( mH )	1.0	5.0
Commutation	copper -graphite	
Bearings	pre-loaded ball	
Maximum radial load	100 N, 12 mm from bearing face	
Maximum axial load	15 N	
Ambient operating temperature range	-10 to +60 °C	
<b>Brake specification</b>		
Nominal Brake Voltage ( Vdc )	24	12
Operating Current ( Amps )	0.22	≤ 0.50
Min. Pull-in voltage ( Vdc )	18	≤ 10
Max. Drop-out voltage ( Vdc )	8	≥ 6
Holding Torque, de-energised ( Ncm )	10	10