



The Future of Analog IC Technology®

# MP2481

## 36V, 1.2A, 1.4MHz White LED Driver

### DESCRIPTION

The MP2481 is a 36V, 1.2A, white LED driver suitable for either step-down or inverting step-up/down applications. It achieves 1.2A peak output current over a wide input supply range with excellent load and line regulation. Current mode operation provides fast transient response and eases loop stabilization. Fault condition protection includes thermal shutdown, cycle-by-cycle peak current limiting, input over voltage protection, open strings protection and output short circuit protection.

The MP2481 incorporates both DC and PWM dimming onto a single control pin. The separate input reference ground pin allows for direct enable and/or dimming control for a positive to negative power conversion.

The MP2481 requires a minimum number of readily available standard external components and is available in 8-pin MSOP8E package.

### EVALUATION BOARD REFERENCE

Board Number	Mode
EV2481-H-00A	Step-down
EV2481-H-01A	Step-up/down

### FEATURES

- 1.2A Maximum Output Current
- Unique Step-up/down Operation (Buck-Boost Mode)
- Wide 4.5V to 36V Operating Input Range for Step-Down Applications (Buck Mode)
- 0.30Ω Internal Power MOSFET Switch
- Fixed 1.4MHz Frequency
- Analog and PWM Dimming
- 0.2V Reference Voltage
- Up to 95% Efficiency
- 5μA Shutdown Mode
- No minimum LED required
- Stable with Low ESR Output Ceramic Capacitors
- Cycle-by-Cycle Over Current Protection
- Thermal Shutdown Protection
- Open Strings Protection
- Input Over Voltage Protection
- Output Short Circuit Protection
- Available in 8-Pin MSOP8E Package

### APPLICATIONS

- General LED Illuminations
- LCD Backlight Panels
- Handheld Computers
- Automotive Internal Lighting
- Portable Multimedia Players
- Portable GPS Devices

All MPS parts are lead-free and adhere to the RoHS directive. For MPS green status, please visit MPS website under Quality Assurance. "MPS" and "The Future of Analog IC Technology" are Trademarks of Monolithic Power Systems, Inc.

## TYPICAL APPLICATION (STEP-UP/DOWN APPLICATION)

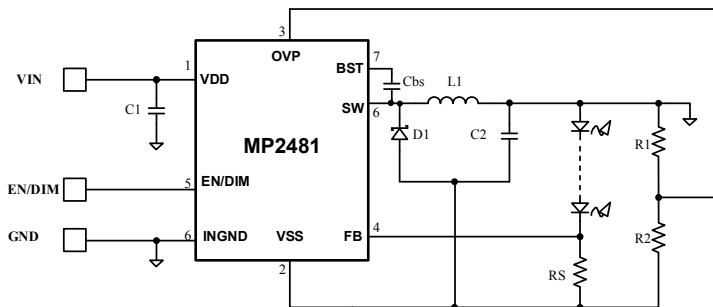

Efficiency vs. Input Voltage

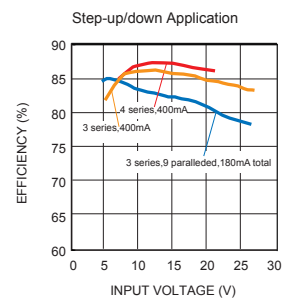

### ORDERING INFORMATION

Part Number*	Package	Top Marking
MP2481DH	MSOP8E	2481D

\* For Tape & Reel, add suffix –Z (e.g. MP2481DH–Z).  
 For RoHS compliant packaging, add suffix –LF (e.g. MP2481DH–LF–Z)

### PACKAGE REFERENCE

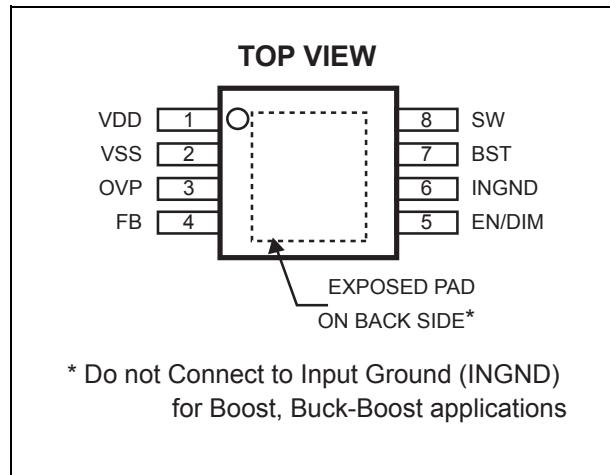

#### ABSOLUTE MAXIMUM RATINGS <sup>(1)</sup>

Supply Voltage $V_{DD} - V_{SS}$ .....	40V
$V_{SW} - V_{SS}$ .....	-0.3V to $V_{IN} + 0.3V$
$V_{BST}$ .....	$V_{SW} + 6V$
$V_{OVP} - V_{SS}$ .....	-0.3V to +6V
$V_{EN} - V_{INGND}$ .....	-0.3V to +6V
$V_{DIM} - V_{INGND}$ .....	-0.3V to +6V
$V_{INGND} - V_{SS}$ .....	-0.3V to 40V
Continuous Power Dissipation ( $T_A = +25^\circ C$ ) <sup>(2)</sup>	2.3W
Junction Temperature .....	150°C
Lead Temperature .....	260°C
Storage Temperature .....	-65°C to +150°C

#### Recommended Operating Conditions <sup>(3)</sup>

Supply Voltage $V_{DD} - V_{SS}$ .....	4.5V to 36V
Operating Junct. Temp ( $T_J$ ) .....	-40°C to +125°C

Thermal Resistance <sup>(4)</sup>	$\theta_{JA}$	$\theta_{JC}$
MSOP8E (Exposed Pad) .....	55	12... °C/W

#### Notes:

- Exceeding these ratings may damage the device.
- The maximum allowable power dissipation is a function of the maximum junction temperature  $T_J$  (MAX), the junction-to-ambient thermal resistance  $\theta_{JA}$ , and the ambient temperature  $T_A$ . The maximum allowable continuous power dissipation at any ambient temperature is calculated by  $P_D$  (MAX) =  $(T_J$  (MAX) -  $T_A$ ) /  $\theta_{JA}$ . Exceeding the maximum allowable power dissipation will cause excessive die temperature, and the regulator will go into thermal shutdown. Internal thermal shutdown circuitry protects the device from permanent damage.
- The device is not guaranteed to function outside of its operating conditions.
- Measured on JESD51-7, 4-layer PCB.

## ELECTRICAL CHARACTERISTICS

$V_{IN} = 12V$ ,  $T_A = +25^{\circ}C$ , all voltages with respect to  $V_{SS}$ , unless otherwise noted.

Parameters	Symbol	Condition	Min	Typ	Max	Units
Feedback Voltage	$V_{FB}$	$4.5V \leq V_{IN} \leq 36V$	0.187	0.203	0.219	V
Feedback Current	$I_{FB}$	$V_{FB} = 0.2V$		0.2		$\mu A$
Switch-On Resistance <sup>(5)</sup>	$R_{DS(ON)}$			0.30		$\Omega$
Switch Leakage		$V_{EN} = 0V, V_{SW} = 0V$			10	$\mu A$
Switch Current Limit <sup>(5)</sup>				2.0		A
Oscillator Frequency	$f_{SW}$	$V_{FB} = 0.1V$	1.0	1.4	1.8	MHz
Fold-back Frequency		$V_{OVP} < 0.4V$		120		kHz
Maximum Duty Cycle		$V_{FB} = 0.1V$		89		%
Minimum On-Time <sup>(5)</sup>	$t_{ON}$			100		ns
Under Voltage Lockout Threshold Rising			3.1	3.4	3.7	V
Under Voltage Lockout Threshold Hysteresis				480		mV
EN Input Current		$V_{EN} = 2V$		2.0		$\mu A$
		$V_{EN} = 0V$		0.1		
EN OFF Threshold (w/Respect to INGND)		$V_{EN}$ Falling	0.4			V
EN ON Threshold (w/Respect to INGND)		$V_{EN}$ Rising			0.7	V
Supply Current (Quiescent)	$I_Q$	$V_{EN} = 2V, V_{FB} = 1V$		0.6	1.1	mA
Thermal Shutdown <sup>(5)</sup>				150		$^{\circ}C$
Open LED OV Threshold	$V_{OVP, th}$			1.23		V
Open LED OV Hysteresis	$V_{OVP, hys}$			0.1		V

**Note:**

5) Guaranteed by design.

## PIN FUNCTIONS

Pin #	Name	Description
1	VDD	Supply Voltage. The MP2481 operates from a +4.5V to +36V unregulated input (with respect to VSS). C1 is needed to prevent large voltage spikes from appearing at the input.
2	VSS	Power Return Pin. Connect to the lowest potential in the circuit, which is typically the anode of the Schottky rectifier. This pin is the voltage reference for the regulated output voltage. For this reason care must be taken in its layout. This node should be placed outside of the D1 to C1 ground path to prevent switching current spikes from inducing voltage noise into the part. The exposed pad is also connected to this pin.
3	OVP	Over Voltage Protection Pin. Use one external resistor voltage divider to program OVP threshold. When the OVP pin voltage (with respect to VSS) is lower than 0.4V, the chip frequency will be folded back. Program the OVP pin voltage from 0.4V to 1.23V for normal operation. When the OVP pin voltage reaches the shutdown threshold 1.23V, the switch will be turned off
4	FB	LED Current Feedback Input. MP2481 regulates the voltage across the current sensing resistor between FB and VSS. Connect the current sensing resistor from the bottom of the LED strings to VSS. The FB pin is connected to the bottom of the LED strings. The regulation voltage is 0.2V.
5	EN/DIM	On/Off Control Input and Dimming Command Input. A voltage greater than 0.7V will turn on the chip. When the EN/DIM pin voltage (with respect to INGND) rises from 0.7V to 1.4V, the LED current will change from 0% to 100% of the maximum LED current. To use PWM dimming, apply a 100Hz to 1kHz square wave signal with amplitude greater than 1.4V to this pin.
6	INGND	Input Ground Reference. This pin is the reference for the EN/DIM signal.
7	BST	Bootstrap. A capacitor is connected between SW and BST pins to form a floating supply across the power switch driver. This capacitor is needed to drive the power switch's gate above the supply voltage.
8	SW	Switch Output. SW is the source of the internal MOSFET switch. Connect to the power inductor and cathode of the Schottky rectifier.

### TYPICAL PERFORMANCE CHARACTERISTICS

$V_{IN}=12V$ ,  $I_{LED}=1A$ , one 5W WLED, Step-down application (refer to Figure 6), unless otherwise noted.

**Steady State Operation**

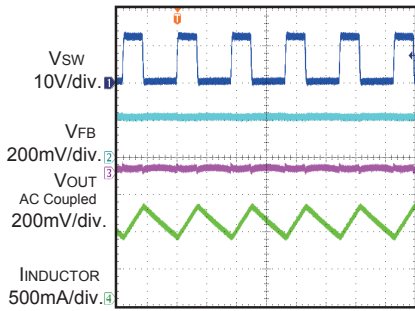

400ns/div

**PWM Dimming**

$f_{PWM}=1kHz, DPWM=50\%$

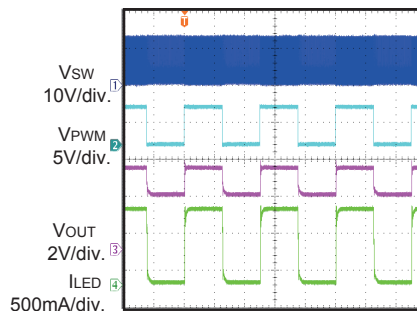

400µs/div

**Open Load Protection**

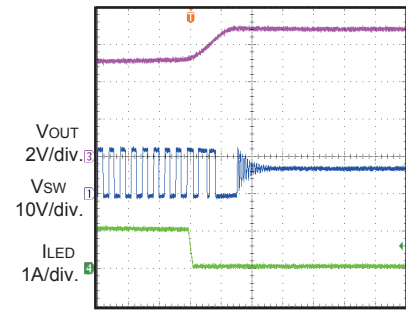

2µs/div

**Short Circuit Protection**

Short LED+ to INGND

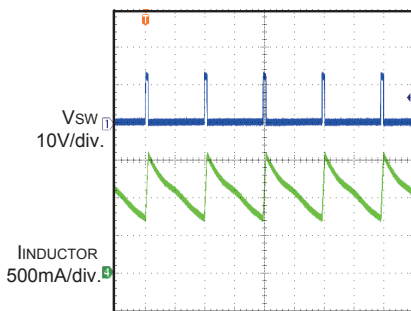

4µs/div

**Efficiency vs. Input Voltage**

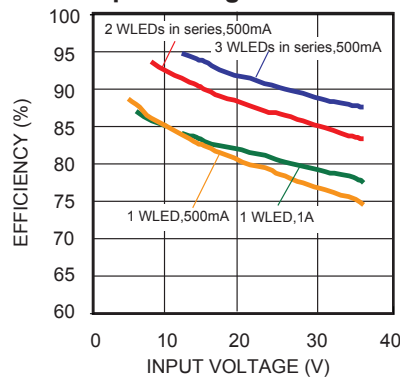

**LED Current vs. Analog Dimming Voltage**

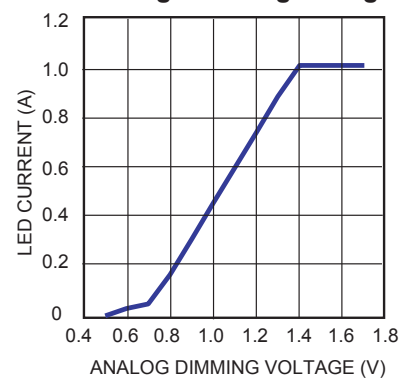

**LED Current vs. PWM Dimming Duty**

$f_{PWM}=1kHz$

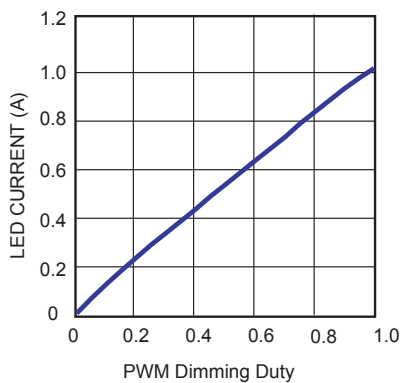

**TYPICAL PERFORMANCE CHARACTERISTICS** *(continued)*

$V_{IN}=12V$ ,  $I_{LED}=180mA$ , 3 WLEDs in series, 9 strings, Step-up/down application (refer to Figure 7), unless otherwise noted.

**Steady State Operation**

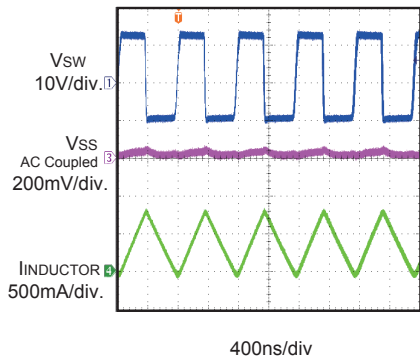

**PWM Dimming**

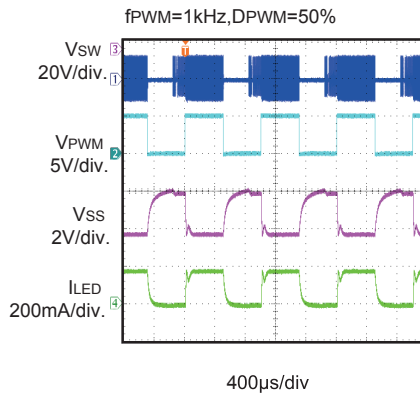

**Open Load Protection**

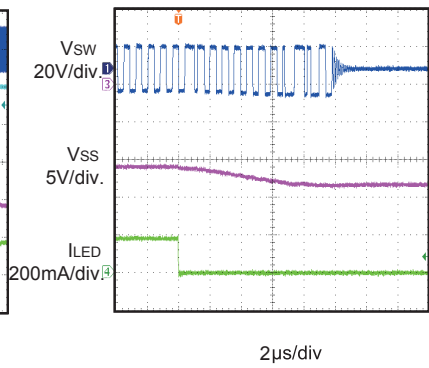

**Short Circuit Protection**

Short LED+ to VSS

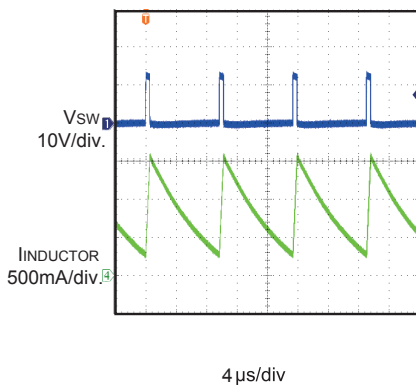

**Efficiency vs. Input Voltage**

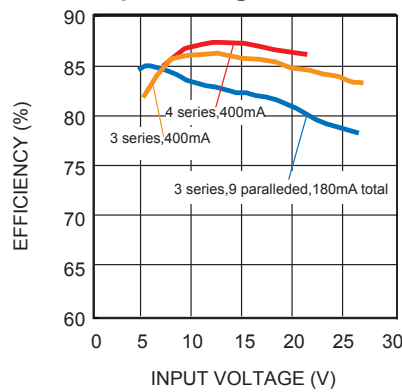

**LED Current vs. Analog Dimming Voltage**

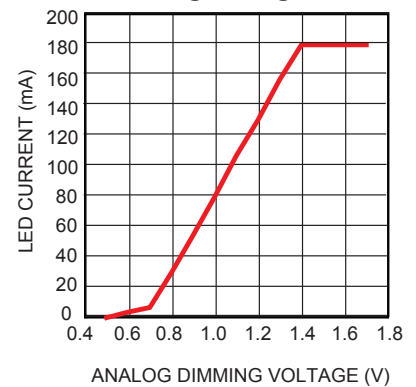

**LED Current vs. PWM Dimming Duty**

fPWM=1kHz

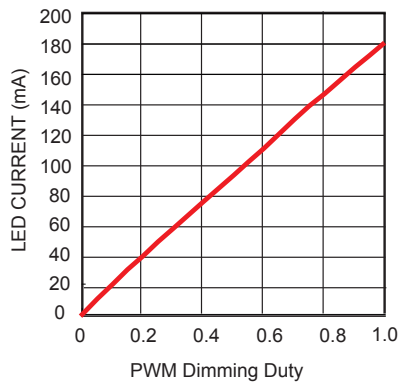

FUNCTION BLOCK DIAGRAM

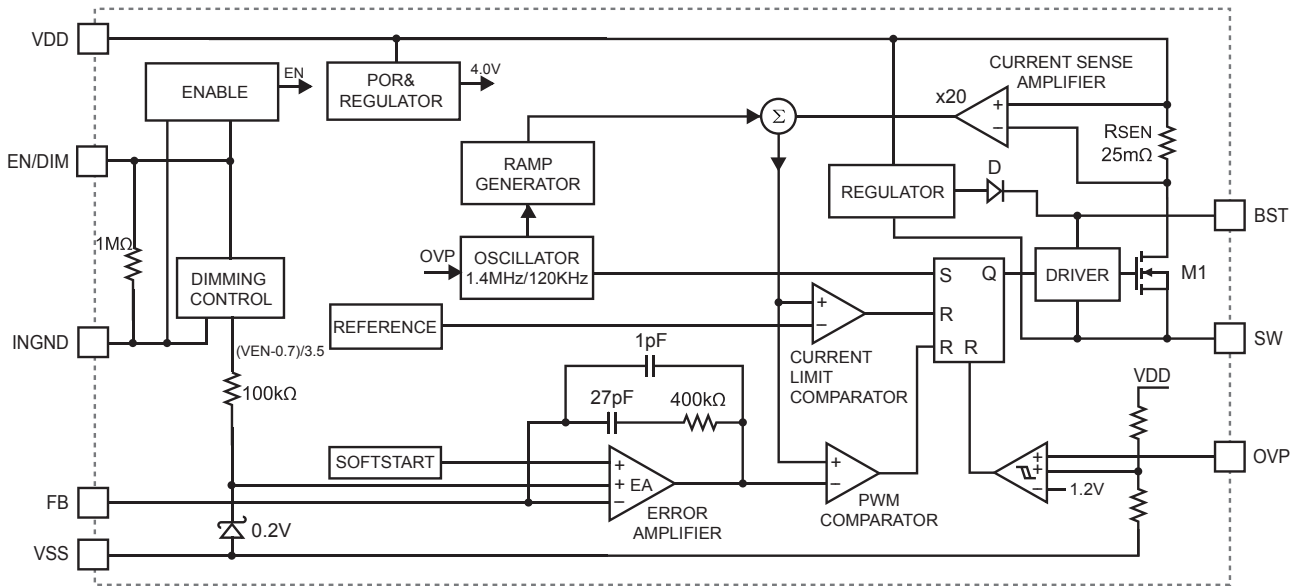

Figure 1—Function Block Diagram

## OPERATION

The MP2481 is a current mode regulator. The EA output voltage is proportional to the peak inductor current.

At the beginning of a cycle, M1 is off. The EA output voltage is higher than the current sense amplifier output, and the current comparator's output is low. The rising edge of the 1.4MHz CLK signal sets the RS Flip-Flop. Its output turns on M1 thus connecting the SW pin and inductor to the input supply.

The increasing inductor current is sensed and amplified by the Current Sense Amplifier. Ramp compensation is summed to the Current Sense Amplifier output and compared to the Error Amplifier output by the PWM Comparator. When the sum of the Current Sense Amplifier output and the Slope Compensation signal exceeds the EA output voltage, the RS Flip-Flop is reset and M1 is turned off. The external Schottky rectifier diode (D1) conducts the inductor current.

If the sum of the Current Sense Amplifier output and the Slope Compensation signal does not exceed the EA output for a whole cycle, then the falling edge of the CLK resets the Flip-Flop.

The output of the Error Amplifier integrates the voltage difference between the feedback and the 0.2V reference. The polarity is such that a FB pin voltage lower than 0.2V increases the EA output voltage. Since the EA output voltage is proportional to the peak inductor current, an increase in its voltage also increases current delivered to the output.

### Open Strings Protection

If LED strings are open, there is no voltage on the FB pin. The duty cycle increases until  $V(VDD) - V(VSS)$  reaches to 38V or  $V(OVP) - V(VSS)$  reaches the shutdown threshold 1.23V. Then the top switch is kept off. It will be switching again when the voltage  $V(VDD) - V(VSS)$  and  $V(OVP) - V(VSS)$  decreases sufficiently.

### Spike Voltage Suppression and EMI Improvement

The spike voltage of the VDD-to-SW should be well limited to make sure it's under the ABS of VDD-to-SW. The high di/dt caused by MOS on/off is the source of spike voltage, which generates high spike voltage on the parasitic

inductor and it's also the source of the EMI. Decrease the parasitic inductance is the most effective method to improve the spike voltage and EMI. As Figure 2 shows, the input capacitor C2 together with the output capacitor C5 offers a bypass paths for high di/dt, so these two capacitor should be placed very close to the chip with short, direct and wide traces.

If the spike voltage still cannot meet the request, or EMI is not so good, a capacitor connected between VDD and VSS can be used to further shorten the high di/dt path. It should be placed as close as possible to the chip too, and the traces should be short and wide. But a schottky diode D5 paralleled with C5 should be used to clamp the voltage between VSS and INGND to make sure it is under the ABS.

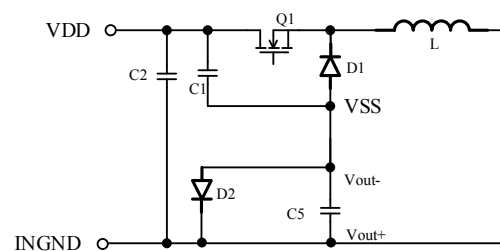

Figure 2— spike voltage and EMI improvement

### Dimming Control

The MP2481 allows both DC and PWM dimming. When  $V(EN/DIM) - V(INGND)$  is less than 0.4V, the chip is turned off. For analog dimming, when  $V(EN/DIM) - V(INGND)$  rises from 0.7V to 1.4V, the LED current will change from 0% to 100% of the maximum LED current. If  $V(EN/DIM) - V(INGND)$  is higher than 1.4V, maximum LED current is generated. If a PWM signal is used, its amplitude  $V(EN/DIM) - V(INGND)$  must exceed 1.4V.

The MP2481 is designed with an internal EN shut-down delay (see Figure 3). If EN is pulled down, the FB reference drops to zero immediately and the LED current decreases. But the IC keeps internal logic on for about 2.5ms. In this period, the IC may switch with very short pulses in pulse-skipping mode, while the LED current is zero since the FB reference is zero. It has benefit that the IC will start up more quickly



without delay when next PWM duty comes. This function offers the possibility to extend the PWM

dimming frequency and also the minimum PWM on time for further dimming depth.

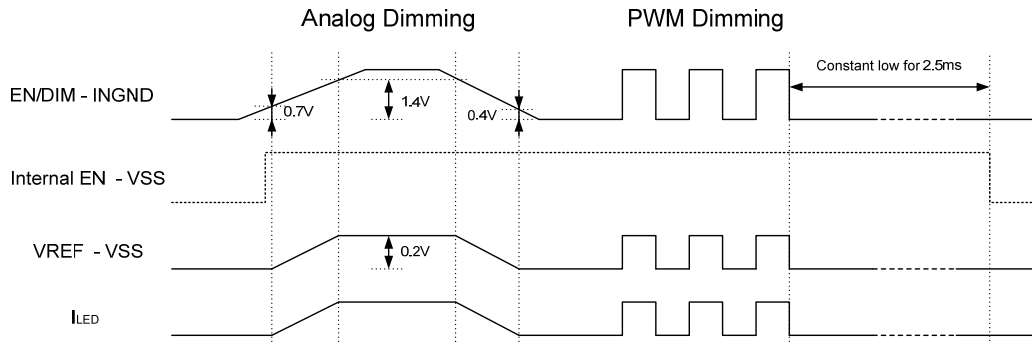

Figure 3— Internal EN Shut-down Delay Function Waveform Diagram

## APPLICATION INFORMATION

### Setting the LED Current

The external resistor is used to set the maximum LED current (see the schematic on front page) through the use of the equation:

$$R_{\text{SENSE}} = \frac{0.200\text{V}}{I_{\text{LED}}}$$

### Setting the OVP point

To make sure the chip functions properly, the Over Voltage Protection (OVP) resistor divider must be set with proper value, the recommended OVP point is about 1.3~1.5 times higher than the output voltage for normal operation and over voltage protection.

### Selecting the Inductor

#### (Step-Down Applications, see Figure 6)

A 3.3μH to 10μH inductor with a DC current rating of at least 25% higher than the maximum load current is recommended for most applications. For highest efficiency, the inductor's DC resistance should be less than 200mΩ. Refer to Table 1 for suggested surface mount inductors. For most designs, the required inductance value can be derived from the following equation.

$$L = \frac{V_{\text{OUT}} \times (V_{\text{IN}} - V_{\text{OUT}})}{V_{\text{IN}} \times \Delta I_L \times f_{\text{SW}}}$$

Where  $V_{\text{IN}}$  is the lowest input voltage,  $V_{\text{OUT}}$  is the output voltage,  $\Delta I_L$  is the inductor ripple current.

Choose the inductor ripple current to be 30% of the maximum load current. The maximum inductor peak current is calculated from:

$$I_{L(\text{MAX})} = I_{\text{LOAD}} + \frac{\Delta I_L}{2}$$

**Table 1—Suggested Surface Mount Inductors**

Manufacturer	Part Number	Inductance(μH)	Max DCR(Ω)	Current Rating (A)	Dimensions L x W x H (mm <sup>3</sup> )
Toko	A921CY-4R7M	4.7	0.027	1.66	6 x 6.3 x 3
Sumida	CDRH4D28C/LD	4.7	0.036	1.5	5.1 x 5.1 x 3
Würth Electronics	7440530047	4.7	0.038	2.0	5.8 x 5.8 x 2.8

If the calculation of above equations results in an inductance greater than 10uH, a 10uH inductor is still preferred.

Under light load conditions below 100mA, a larger inductance is recommended for improved efficiency.

Also note that the maximum recommended load current is 1A if the duty cycle exceeds 35%.

#### (Step up/Down Applications, see Figure 7)

Operation at step-up/down mode, the recommended inductance value can be derived from the following equation:

$$L = \frac{-V_{\text{OUT}} \times V_{\text{IN}}}{(V_{\text{IN}} - V_{\text{OUT}}) \times \Delta I_L \times f_{\text{SW}}}$$

When  $V_{\text{IN}}$  is the lowest input voltage,  $V_{\text{OUT}}$  is the output voltage (negative),  $\Delta I_L$  is the inductor ripple current.

For most step-up/down applications, a 3.3uH to 22uH with suitable DC current rating is recommended. See Table 1 for suggested inductors.

### Selecting the Input Capacitor

The input capacitor reduces the surge current drawn from the input supply and the switching noise from the device. The input capacitor impedance at the switching frequency should be less than the input source impedance to prevent high frequency switching current from passing through the input. Ceramic capacitors with X5R or X7R dielectrics are highly recommended because of their low ESR and small temperature coefficients. For most applications, a 4.7μF capacitor is sufficient.

**Selecting the Output Capacitor**

The output capacitor keeps the output voltage ripple small and ensures feedback loop stability. The output capacitor impedance should be low at the switching frequency. Ceramic capacitors with X5R or X7R dielectrics are recommended for their low ESR characteristics. For most applications, a 2.2µF ceramic capacitor will be sufficient.

**PCB Layout Considerations**

Efficient PCB layout is critical for stable operation. For best results, please refer to the guidelines below:

1. The high di/dt paths (VSS, VDD and SW) should be placed very close to the device with short, direct and wide traces.
2. The input capacitor needs to be as close as possible to the VDD and VSS pins.

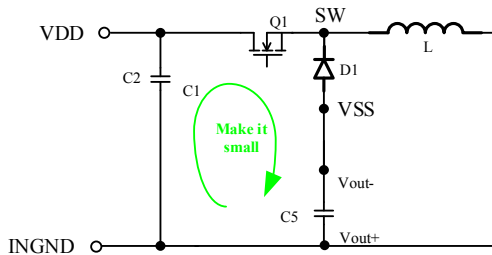

**Figure 4—Buck-boost layout without VSS capacitor**

3. The external feedback resistors should be placed next to the FB pin.
4. Keep the switch node traces short and away from the feedback network.
5. Add a capacitor between VSS and VDD when the capacitor between VDD and INGND cannot be placed as close to the device as possible. Make sure the capacitor between VSS and VDD is very close to the device and the traces are short and wide.

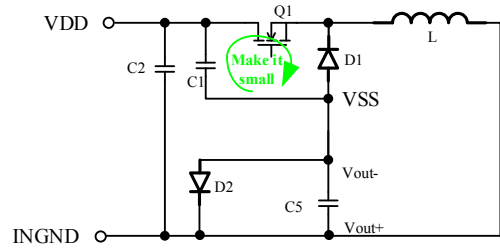

**Figure 5— Buck-boost layout without VSS capacitor**

TYPICAL APPLICATION CIRCUITS

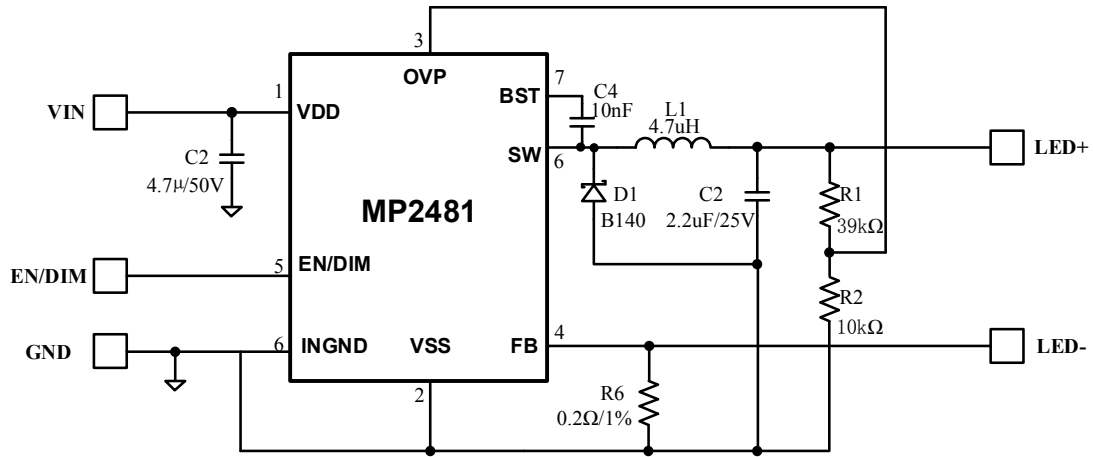

Figure 6—Step-Down White LED Driver Application

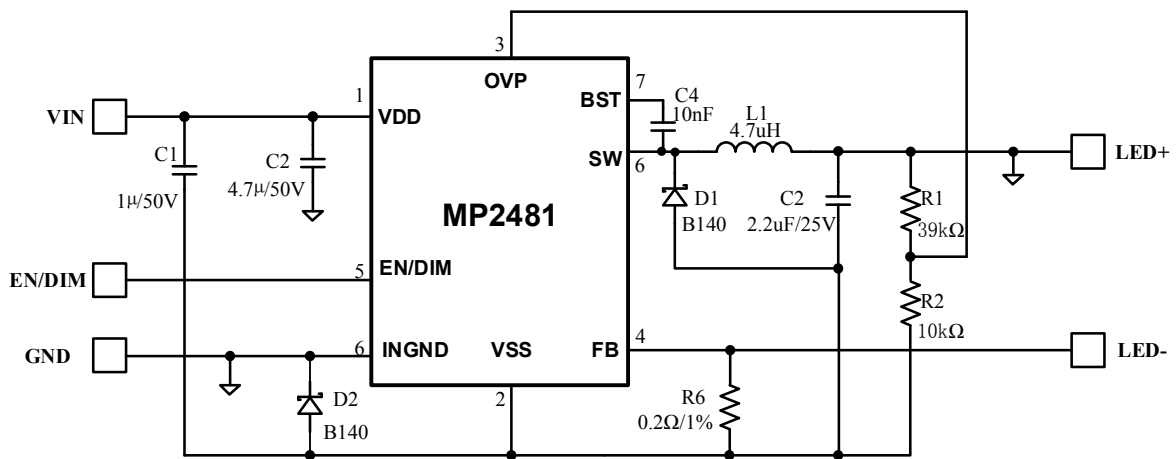
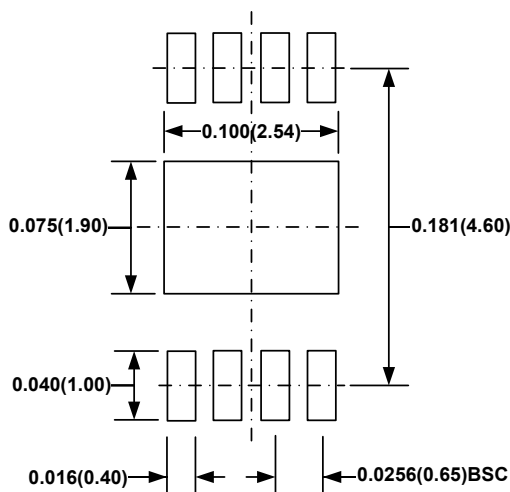
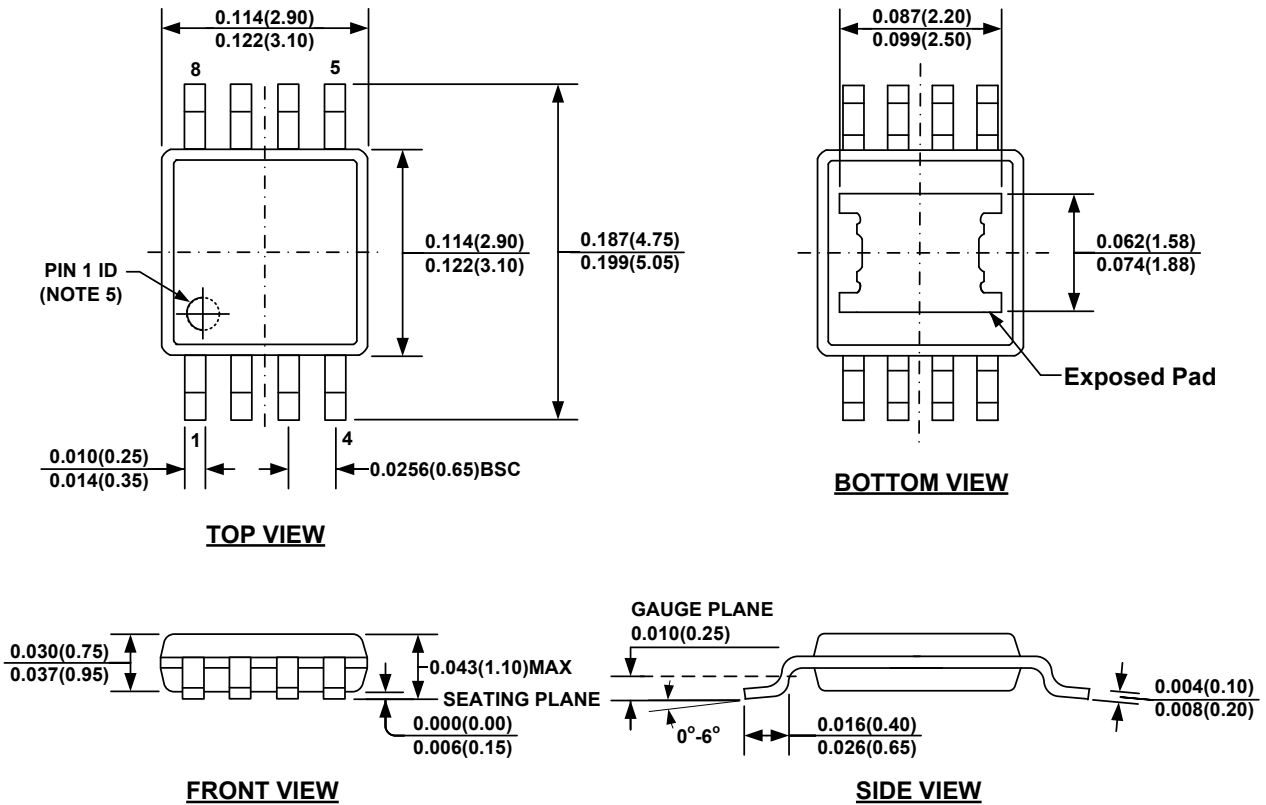

Figure 7—Step-up/down White LED Driver Application

**PACKAGE INFORMATION**
**MSOP8E W/ EXPOSED PAD**

**NOTE:**

- 1) CONTROL DIMENSION IS IN INCHES. DIMENSION IN BRACKET IS IN MILLIMETERS.
- 2) PACKAGE LENGTH DOES NOT INCLUDE MOLD FLASH, PROTRUSION OR GATE BURR.
- 3) PACKAGE WIDTH DOES NOT INCLUDE INTERLEAD FLASH OR PROTRUSION.
- 4) LEAD COPLANARITY (BOTTOM OF LEADS AFTER FORMING) SHALL BE 0.004" INCHES MAX.
- 5) PIN 1 IDENTIFICATION HAS HALF OR FULL CIRCLE OPTION.
- 6) DRAWING MEETS JEDEC MO-187, VARIATION AA-T.
- 7) DRAWING IS NOT TO SCALE.

## Revision History

Revision #	Revision Date	Description	Pages Updated
1.5	08/24/2020	1. Updated the typical application	Page 1
		2. Updated the PCB layout consideration	page 11
		3. Updated the typical application circuit	page 12

**NOTICE:** The information in this document is subject to change without notice. Please contact MPS for current specifications. Users should warrant and guarantee that third party Intellectual Property rights are not infringed upon when integrating MPS products into any application. MPS will not assume any legal responsibility for any said applications.