

# DSA20C60PN

## 60 V, 20 A Schottky Rectifier Diode

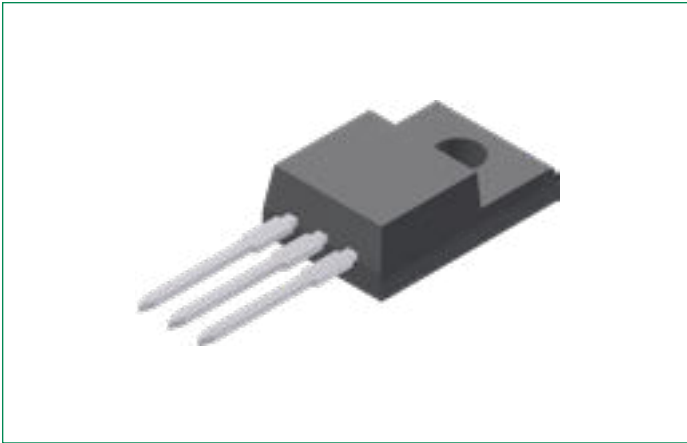

### Pinout Diagram (TO-220-3L ABFP)

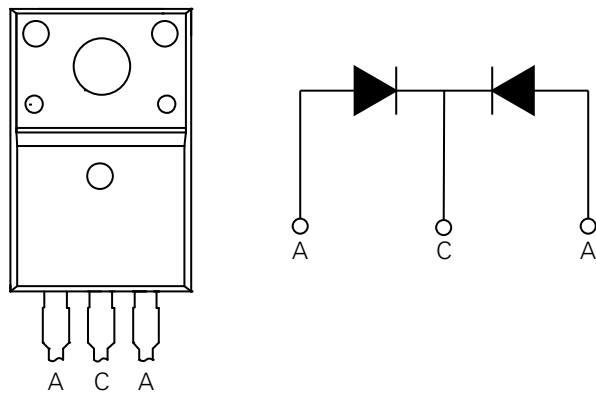

**A:** Anode; **C:** Cathode

### Features:

- Very low  $V_F$
- Extremely low switching losses
- Low  $I_{RM}$  values
- Improved thermal behaviour
- High reliability circuit operation
- Low voltage peaks for reduced protection circuits
- Low noise switching
- Terminals finish: 100% Pure Tin
- This is a Pb-free device
- Epoxy meets UL 94V-0
- Isolation Voltage:  $V \sim 2500$
- Soldering pins for PCB mounting
- Base plate: Plastic over molded tab

### Applications:

- Switching power supply
- Free-Wheeling diodes
- Converters
- Reverse battery protection

### Product Summary

Characteristic	Value	Unit
$V_{RRM}$	60	V
$I_{FAV}$	$2 \times 10$	A
$V_F$	0.70	V

### Maximum Ratings

Symbol	Characteristic	Conditions	Value	Unit	
$V_{RRM}$	Peak Repetitive Reverse Voltage	-	60	V	
$V_{RWM}$	Working Peak Reverse Voltage				
$V_R$	DC Blocking Voltage				
$I_{FAV}$	Average Rectified Forward Current	50% duty cycle @ $T_C = 140\text{ }^\circ\text{C}$ , rectangular wave form	per leg	10	A
			per device	20	A
$I_{FSM}$	Peak One Cycle Non-Repetitive Surge Current (per leg)	10 ms, Half Sine pulse, $T_{VJ} = 25\text{ }^\circ\text{C}$	240	A	
$P_{tot}$	Total Power Dissipation	$T_C = 25\text{ }^\circ\text{C}$	26	W	

### Electrical Characteristics ( $T_J = 25\text{ }^\circ\text{C}$ unless otherwise specified)

Symbol	Characteristic	Conditions	Value			Unit
			Min.	Typ.	Max.	
$V_{F1}$	Forward Voltage Drop (per leg) <sup>1</sup>	@10 A, Pulse, $T_{VJ} = 25\text{ }^\circ\text{C}$	-	-	0.86	V
$V_{F2}$		@10 A, Pulse, $T_{VJ} = 125\text{ }^\circ\text{C}$	-	-	0.70	V
$I_{R1}$	Reverse Current (per leg) <sup>1</sup>	@ $V_R = \text{rated } V_{R'}$ , $T_{VJ} = 25\text{ }^\circ\text{C}$	-	-	200	$\mu\text{A}$
$I_{R2}$		@ $V_R = \text{rated } V_{R'}$ , $T_{VJ} = 125\text{ }^\circ\text{C}$	-	-	15	mA
$C_T$	Junction Capacitance (per leg)	@ $V_R = 12\text{ V}$ , $T_C = 25\text{ }^\circ\text{C}$ , $f_{sig} = 1\text{ MHz}$	-	194	-	pF
$V_{ISO}$	Isolation Voltage	$t = 1\text{ sec.}$ , 50/60 Hz. RMS; $I_{ISOL} \leq 1\text{ mA}$	2500	-	-	V
		$t = 1\text{ min.}$ , 50/60 Hz. RMS; $I_{ISOL} \leq 1\text{ mA}$	2100	-	-	

**Note 1:** Pulse width < 300  $\mu\text{s}$ , duty cycle < 2%

### Thermal-Mechanical Specifications

Symbol	Characteristics	Condition	Specification	Units
$T_{VJ}$	Junction Temperature	-	-55 to +150	$^\circ\text{C}$
$T_O$	Operation Temperature	-	-55 to +150	$^\circ\text{C}$
$T_{stg}$	Storage Temperature	-	-55 to +150	$^\circ\text{C}$
$M_D$	Mounting Torque	-	Min 0.4 Max 0.6	Nm
$F_C$	Mounting Force with clip	-	Min 20 Max 60	N
$R_{\theta JC}$	Maximum Thermal Resistance Junction to Case	DC operation	4.8	$^\circ\text{C/W}$
$R_{\theta CS}$	Typical Thermal Resistance Case to Heat Sink	-	0.50	$^\circ\text{C/W}$
wt	Approximate Weight	-	2	g

## Characteristic Curves

**Fig. 1. Typical Forward Characteristics**

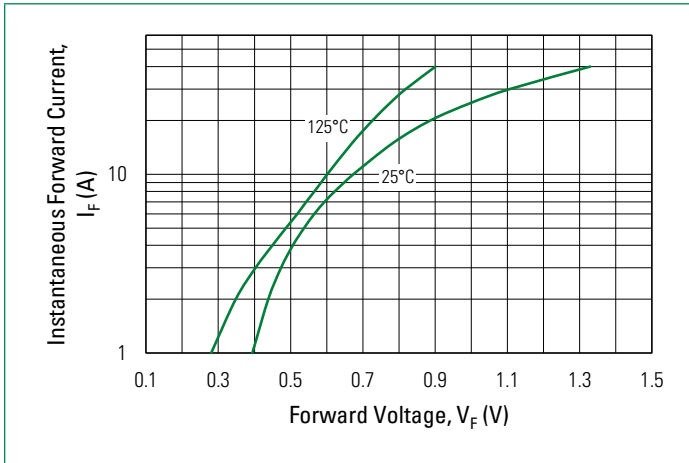

**Fig. 2. Typical Reverse Characteristics**

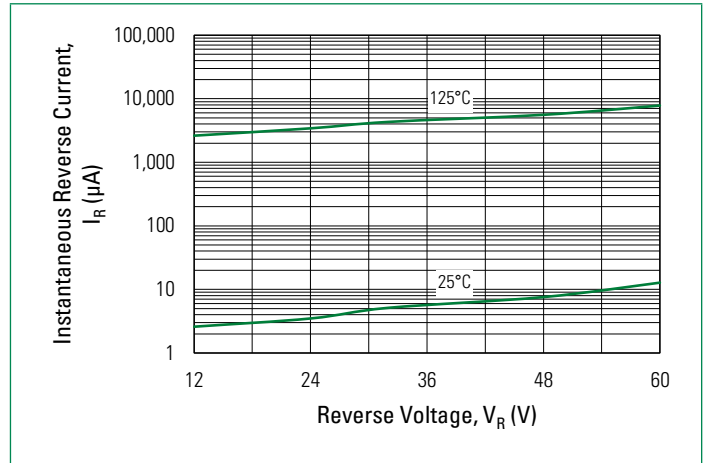

**Fig. 3. Typical Junction Capacitance**

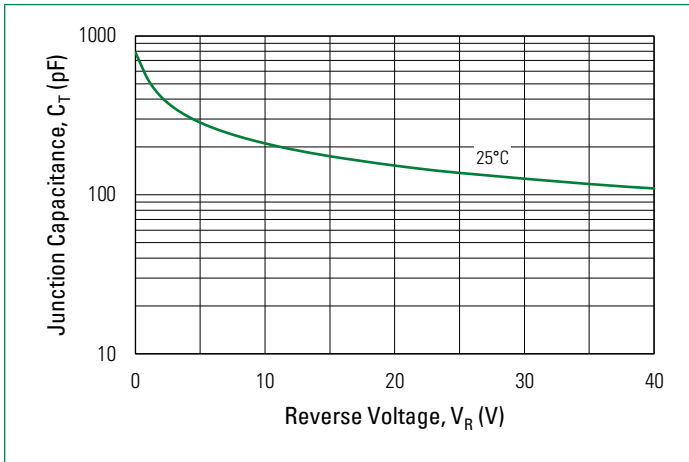

Part Outline Drawing (TO-220-3L ABFP)

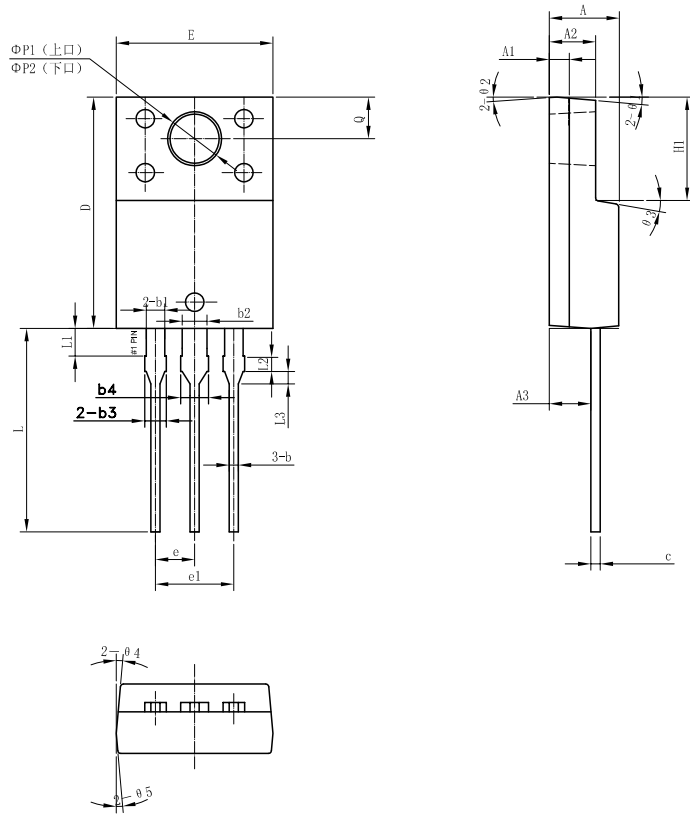

Symbol	Inches			Millimeters		
	Min.	Typical	Max.	Min.	Typical	Max
A	0.169	0.177	0.185	4.30	4.50	4.70
A1	0.043	0.051	0.059	1.10	1.30	1.50
A2	0.110	0.118	0.126	2.80	3.00	3.20
A3	0.098	0.106	0.114	2.50	2.70	2.90
b	0.020	0.024	0.03	0.50	0.60	0.75
b1	0.043	0.047	0.053	1.10	1.20	1.35
b2	0.059	0.063	0.069	1.50	1.60	1.75
b3	0.047	0.051	0.057	1.20	1.30	1.45
b4	0.063	0.067	0.073	1.60	1.70	1.85
c	0.020	0.024	0.030	0.50	0.60	0.75
D	0.583	0.591	0.598	14.80	15.00	15.20
E	0.392	0.400	0.408	9.96	10.16	10.36
e	-	0.100	-	-	2.55	-
e1	-	0.201	-	-	5.10	-
H1	0.256	0.264	0.272	6.50	6.70	6.90
L	0.500	0.520	0.539	12.70	13.20	13.70
L1	0.063	0.071	0.079	1.60	1.80	2.00
L2	0.031	0.039	0.047	0.80	1.00	1.20
L3	0.024	0.031	0.039	0.60	0.80	1.00
ØP1	0.130	0.138	0.146	3.30	3.50	3.70
ØP2	0.118	0.126	0.133	2.99	3.19	3.39
Q	0.098	0.106	0.114	2.50	2.70	2.90

Part Numbering and Marking

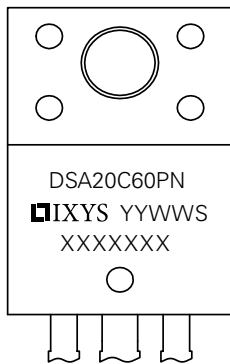

- DS = Schottky Diode
- A = Product Generation
- 20 = Current Rating (20 A)
- C = Common Cathode
- 60 = Voltage Rating (60 V)
- PN = Package Code
- YY = Year
- WW = Work Week
- S = Plant Location Code
- XXXXXXX = Lot Number

Packing Specifications

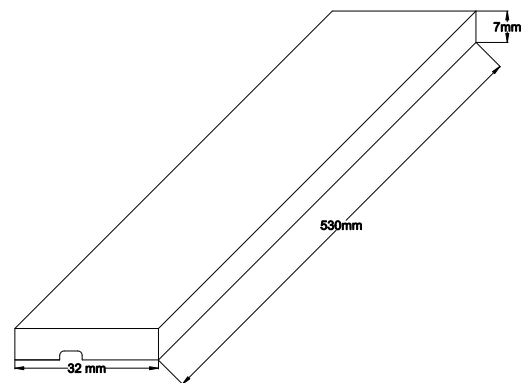

Ordering Information

Part Number	Marking	Packing Mode	M.O.Q.
DSA20C60PN	DSA20C60PN	Tube (50 pcs)	-

Disclaimer Notice

Information furnished is believed to be accurate and reliable. However, users should independently evaluate the suitability of and test each product selected for their own applications. Littelfuse products are not designed for, and may not be used in, all applications. Read complete Disclaimer Notice at <http://www.littelfuse.com/disclaimer-electronics>.



Part of:

