

- 1
- 2
- 3
- 4
- 5
- 6
- 7
- 8
- 9
- 10
- 11
- 12
- 13
- 14
- 15
- 16
- 17
- 18

1 **THREADED BODY**
AISI 303 stainless steel.

2 **PLUNGER**
Nickel-plated AISI 303 stainless steel.
Suggested tolerance for matching hole = H7.

3 **LOCKING NUT**
Stainless steel.

4 **KNOB**
High-resilience polyamide based (PA) technopolymer, black colour, matte finish or AISI 303 stainless steel.

- STANDARD EXECUTIONS**
- **GN 313-A-NI**: with knob, without locking nut.
 - **GN 313-AK-NI**: with knob, with locking nut.
 - **GN 313-D-NI**: without knob, without locking nut.
 - **GN 313-DK-NI**: without knob, with locking nut.
 - **index 1**: for plunger without internal threading.
 - **index 2**: for plunger with internal threading.

FEATURES AND APPLICATIONS
GN 313-NI indexing plungers have fully retracted plunger out of gear.
By using the execution with internal threaded plunger (index 2), special devices may operate by means of threaded rods.
GN 313-D-NI and GN 313-DK-NI are without knob for operating by means of pneumatic cylinders, helical cams, etc.



GN 313-A-NI
GN 313-AK-NI

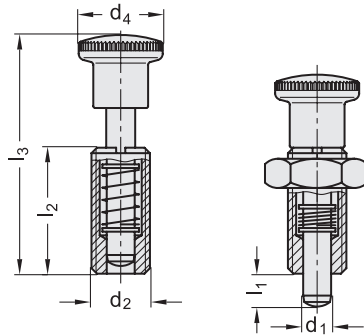

GN 313-..-2

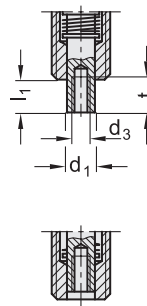

Code	Description	d1 Plunger -0.02-0.04 Hole H7	d2	d3	d4	l1	l2	l3	t	Spring preload [N]	Spring max load [N]	Δ
GN.15049	GN 313-5-A-1-NI	5	M10x1	-	16	6	22	42	-	7	18	12
GN.15050	GN 313-5-A-2-NI	5	M10x1	M3	16	6	22	42	7	7	18	13
GN.15051	GN 313-6-A-1-NI	6	M12x1.5	-	19	7	26	49	-	9	28	18
GN.15052	GN 313-6-A-2-NI	6	M12x1.5	M4	19	7	26	49	7	9	28	20
GN.15053	GN 313-8-A-1-NI	8	M16x1.5	-	23	9	34	65	-	12	40	47
GN.15054	GN 313-8-A-2-NI	8	M16x1.5	M5	23	9	34	65	9	12	40	48
GN.15055	GN 313-10-A-1-NI	10	M20x1.5	-	28	11	43	78	-	22	50	70
GN.15056	GN 313-10-A-2-NI	10	M20x1.5	M6	28	11	43	78	12	22	50	75
GN.15069	GN 313-5-AK-1-NI	5	M10x1	-	16	6	22	42	-	7	18	15
GN.15070	GN 313-5-AK-2-NI	5	M10x1	M3	16	6	22	42	7	7	18	16
GN.15071	GN 313-6-AK-1-NI	6	M12x1.5	-	19	7	26	49	-	9	28	21
GN.15072	GN 313-6-AK-2-NI	6	M12x1.5	M4	19	7	26	49	7	9	28	24
GN.15073	GN 313-8-AK-1-NI	8	M16x1.5	-	23	9	34	65	-	12	40	60
GN.15074	GN 313-8-AK-2-NI	8	M16x1.5	M5	23	9	34	65	9	12	40	65
GN.15075	GN 313-10-AK-1-NI	10	M20x1.5	-	28	11	43	78	-	22	50	80
GN.15076	GN 313-10-AK-2-NI	10	M20x1.5	M6	28	11	43	78	12	22	50	86

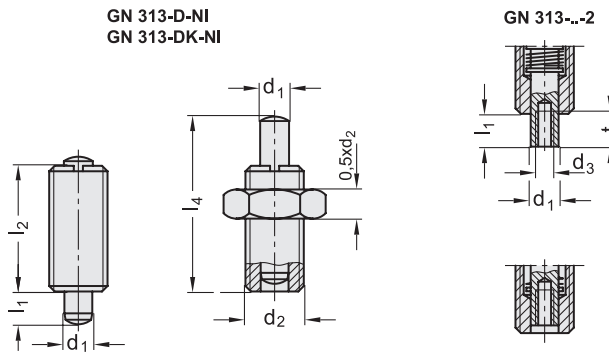

INOX STAINLESS STEEL

Code	Description	d1 Plunger -0.02-0.04 Hole H7	d2	d3	l1	l2	l4	t	Spring preload [N]	Spring max load [N]	⚖
GN.15059	GN 313-5-D-1-NI	5	M10x1	-	6	22	29	-	7	18	16
GN.15060	GN 313-5-D-2-NI	5	M10x1	M3	6	22	29	7	7	18	17
GN.15061	GN 313-6-D-1-NI	6	M12x1.5	-	7	26	35	-	9	28	27
GN.15062	GN 313-6-D-2-NI	6	M12x1.5	M4	7	26	35	7	9	28	27
GN.15063	GN 313-8-D-1-NI	8	M16x1.5	-	9	34	48	-	12	40	70
GN.15064	GN 313-8-D-2-NI	8	M16x1.5	M5	9	34	48	9	12	40	42
GN.15065	GN 313-10-D-1-NI	10	M20x1.5	-	11	43	57	-	22	50	86
GN.15066	GN 313-10-D-2-NI	10	M20x1.5	M6	11	43	57	12	22	50	86
GN.15079	GN 313-5-DK-1-NI	5	M10x1	-	6	22	29	-	7	18	19
GN.15080	GN 313-5-DK-2-NI	5	M10x1	M3	6	22	29	7	7	18	20
GN.15081	GN 313-6-DK-1-NI	6	M12x1.5	-	7	26	35	-	9	28	30
GN.15082	GN 313-6-DK-2-NI	6	M12x1.5	M4	7	26	35	7	9	28	30
GN.15083	GN 313-8-DK-1-NI	8	M16x1.5	-	9	34	48	-	12	40	72
GN.15084	GN 313-8-DK-2-NI	8	M16x1.5	M5	9	34	48	9	12	40	75
GN.15086	GN 313-10-DK-2-NI	10	M20x1.5	-	11	43	57	-	22	50	90
GN.15085	GN 313-10-DK-1-NI	10	M20x1.5	M6	11	43	57	12	22	50	90

Indexing and positioning elements