

OA5108

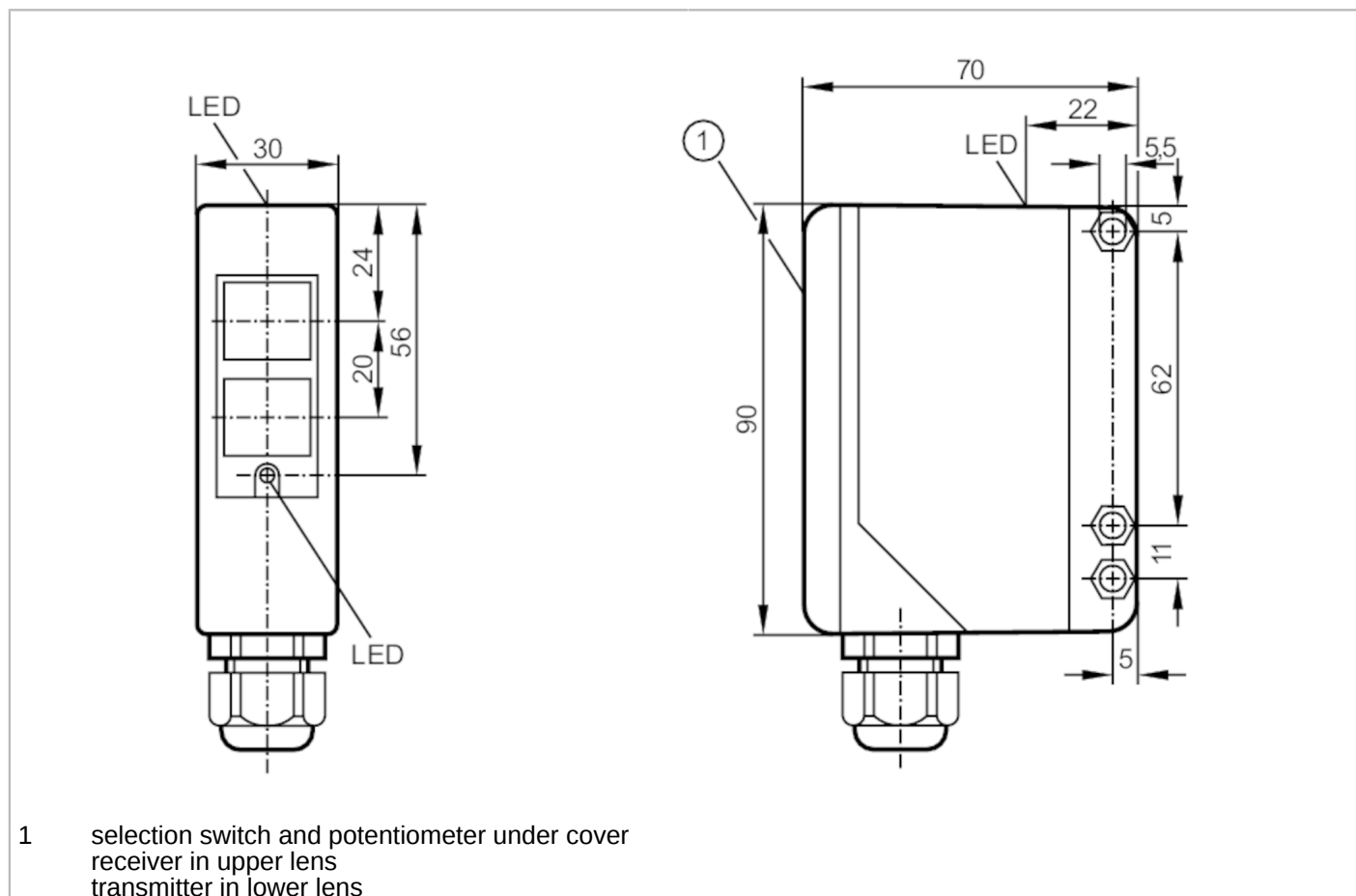

Diffuse reflection sensor

OAT-FCKG



Product characteristics

Type of light	infrared light
Housing	rectangular
Dimensions [mm]	90 x 30 x 70

Application

Special feature	Function check output
Function principle	Diffuse reflection sensor

Electrical data

Operating voltage [V]	10...36 DC
Current consumption [mA]	< 50
Protection class	II
Reverse polarity protection	yes
Type of light	infrared light
Wave length [nm]	880

OA5108



Diffuse reflection sensor

OAT-FCKG

Outputs		
Electrical design	PNP/NPN	
Output function	light-on/dark-on mode; (programmable)	
Function check output	yes	
Max. current load for function check output [mA]	10	
Permanent current rating of switching output DC [mA]	250	
Max. current load in dual output mode [mA]	100	
Switching frequency DC [Hz]	300	
Short-circuit protection	yes	
Type of short-circuit protection	pulsed	
Overload protection	yes	
Detection zone		
Range [mm]	5...1500; (white paper 200 x 200 mm)	
Range adjustable	yes	
Max. light spot diameter [mm]	370	
Light spot dimensions refer to	at maximum range	
Operating conditions		
Ambient temperature [°C]	-25...60	
Protection	IP 65	
Tests / approvals		
EMC	EN 60947-5-2	
MTTF [years]	402	
Mechanical data		
Weight [g]	287	
Housing	rectangular	
Dimensions [mm]	90 x 30 x 70	
Materials	PPO modified	
Lens material	PMMA	
Lens alignment	side lens	
Displays / operating elements		
Display	switching status	1 x LED, yellow
	operation	1 x LED, green
	function	1 x LED, red
Accessories		
Accessories (supplied)	Angle bracket: 1 x, E20514 screwdrivers	
Remarks		
Pack quantity	1 pcs.	

OA5108



Diffuse reflection sensor

OAT-FCKG

Electrical connection

terminals: ...1.5 mm²; Cable sheath: Ø 4.5...10 mm; Cable gland: M16 X 1.5

Connection

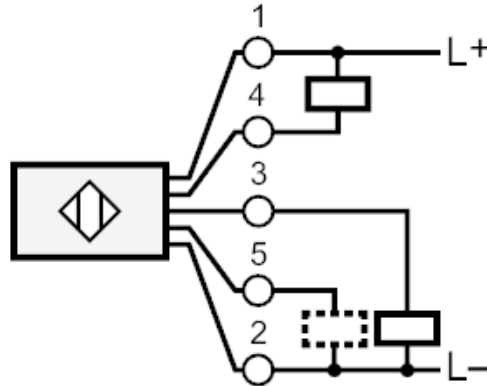

5 Function check output

Diagrams and graphs

excess gain graph

