

VIDEO IF AMPLIFIER WITH DEMODULATOR AND AFC

- SYNCHRONOUS DEMODULATORS
- GAIN CONTROLLED AMPLIFIER
- VERY HIGH INPUT SENSITIVITY
- CONSTANT INPUT IMPEDANCE INDEPENDENT OF AGC
- FIXED VIDEO OUTPUT VOLTAGE WITH SMALL TOLERANCE RANGE
- SWITCHABLE AFC
- POSITIVE OR NEGATIVE AGC GATING PULSE
- VERY FEW EXTERNAL COMPONENTS
- OUTPUT VIDEO SIGNAL NO MUCH AFFECTED BY SUPPLY VOLTAGE VARIATIONS
- THE TDA4426 AND TDA4427 GET DIFFERENT AFC CURVES (inverted AFC for TDA4427)

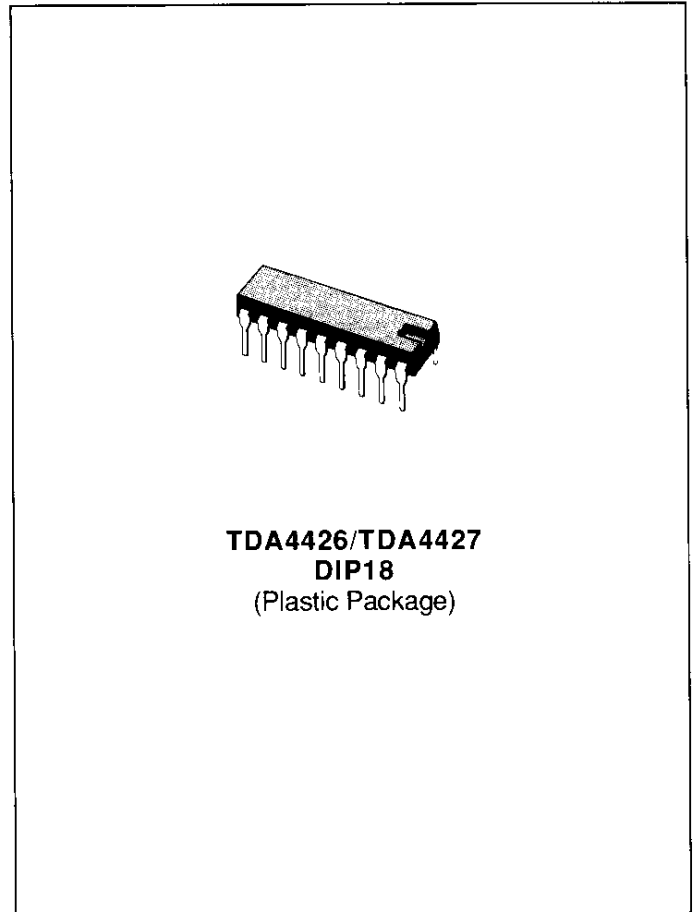

DESCRIPTION

The TDA4426 and TDA4427 are IF amplifier and A.M. demodulator circuits for colour or black and white television receiver using PNP tuner. They are intended for reception of negative or positive modulation CCIR standards.

PIN CONNECTION

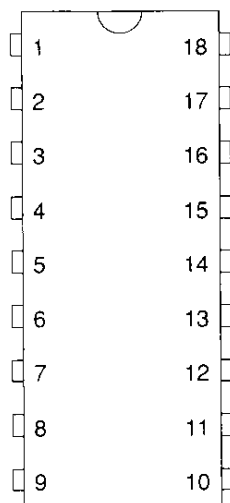

- 1 - IF input
- 2 - Not to be connected
- 3 - Ground
- 4 - AGC filter capacitor
- 5 - Tuner AGC output
- 6 - Tuner AGC adjustment
- 7 - Pulse input for AGC gated
- 8 - Carrier tuned circuit output 1
- 9 - AFC tuned circuit output 1
- 10 - AFC tuned circuit output 2
- 11 - Carrier tuned circuit output 2
- 12 - AFC output
- 13 - Negative video output
- 14 - Positive video output
- 15 - Supply voltage
- 16 - Not to be connected
- 17 - Ground
- 18 - IF input

E88TDA4426-01

APPLICATION CIRCUIT

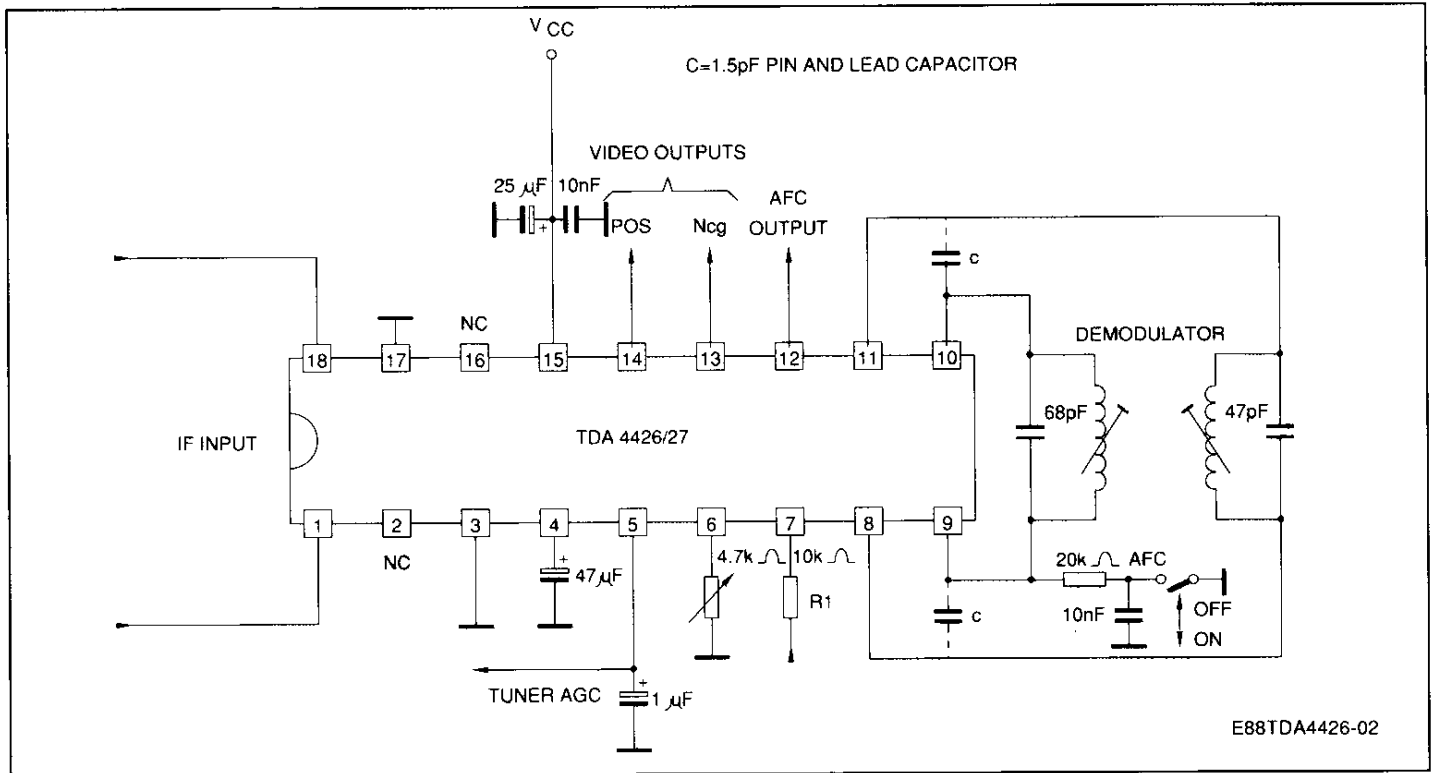

E88TDA4426-02

ABSOLUTE MAXIMUM RATINGS

Symbol	Parameter	Value	Unit
V_{CC}	Supply Voltage	15	V
V_5	Voltage at pin 5	V_{CC}	V
V_4	Voltage at Pin 4	5	V
$I_{13} - I_{14}$	Output Current to Ground (source Current) Max : 1 s	30	mA
$I_{13} - I_{14}$	Output Current from Positive Supply (sink current) Max : 1 s	5	mA
T_j	Junction Temperature	125	°C
T_{amb}	Operating Ambient Temperature	0 to + 70	°C
T_{stg}	Storage Temperature	- 25 to + 125	°C

THERMAL DATA

Symbol	Parameter	Value	Unit
$R_{th(j-a)}$	Junction - ambient Thermal Resistance	80	°C/W

ELECTRICAL OPERATING CHARACTERISTICS
 $T_{amb} = +25\text{ }^{\circ}\text{C}$, $V_{CC} = 12\text{ V}$, $F = 38.9\text{ MHz}$, $m = 80\%$ (unless otherwise specified)

Symbol	Parameter	Min.	Typ.	Max.	Unit
V_{CC}	Supply Voltage	10	12	15	V
I_{CC}	Supply Current $V_4 = 3.5\text{ V}$	35		70	mA
V_{13} V_{14}	Ultra White Level	4.7	5.2 1.8	5.8	V V
V_{13} V_{14}	Top Synchro DC Output Voltage	1.75	1.9 5.0	2.05	V V
$I_{13} - I_{14}$	Output DC Current ($V_{13} = V_{14} = 7\text{ V}$)		1.5		mA
V_7	AGC Pulse Input DC Voltage		1.1		V
R_{1-18} C_{1-18}	Input Impedance		1.6 2		k Ω pF
	Input Voltage Sensitivity (output voltage 3 V_{pp})		100	150	μV
$V_{13} - V_{14}$	IF Residual Carrier at Video Output ($F = 38.9\text{ MHz}$) Pins 13 - 14		20		mVRMS
$V_{13} - V_{14}$	2 nd Harmonic Carrier at Video Output ($F = 77.8\text{ MHz}$) Pins 13 - 14		40		mVRMS
	Differential Distorsion on Compositive Video Signal (pin 13, 14)		3	5	%
	Intermodulation At (input condition) Color Subcarrier (1.07 MHz) PC : Picture Carrier Level = 0 dB CC : Color Subcarrier Level = - 6 dB SC : Sound Carrier Level = - 24 dB		50		dB
V_{13}	Composite Video Output Level	2.7	3.0	3.3	Vpp
V_{14}	$V_I = 30\text{ mV}$ $m = 80\%$ Without Load	2.7	3.0	3.3	Vpp
$\Delta V_{13}/\Delta V_{CC}$, or $\Delta V_{14}/\Delta V_{CC}$	Ultra Black Level Variation with Supply Voltage (V_{CC})		0.5		%
$\Delta V_{13}/\Delta V_{CC}$, or $\Delta V_{14}/\Delta V_{CC}$	Ultra White Level Variation with Supply Voltage (V_{CC})		3		%
BW	Video Bandwidth (- 3 dB) Pins 13 - 14		6		MHz
	AGC Range	55	60		dB
I_{AGCT}	Available Turner Control Output Current (input level 10 dB higher than level threshold)	7	10		mA
	AGC Tuner Range		60		dB
I_5	Tuner AGC Output Leakage Current ($V_5 = 12\text{ V}$)			20	μA
$V_9 - V_{10}$	AFC Tank Pin DC Voltage Pins 9 - 10		3		V
V_{AFC}	AFC Output Voltage Range ($\Delta f = 200\text{ kHz}$) Pin 12	1.0		$V_{CC} - 1.5$	V

ELECTRICAL OPERATING CHARACTERISTICS (continued)

Symbol	Parameter	Min.	Typ.	Max.	Unit
$\pm I_{AFC}$	AFC Output Current Pin 12		1.2		mA
$\pm \frac{\Delta I_{AFC}}{\Delta f}$	AFC Slope		0.2		mA/ 100 kHz
	AFC Output Current (AFC switch off) Pin 12			60	μ A
	Switching Current for AFC Pins 9 - 10	100	150		μ A

TEST CIRCUIT

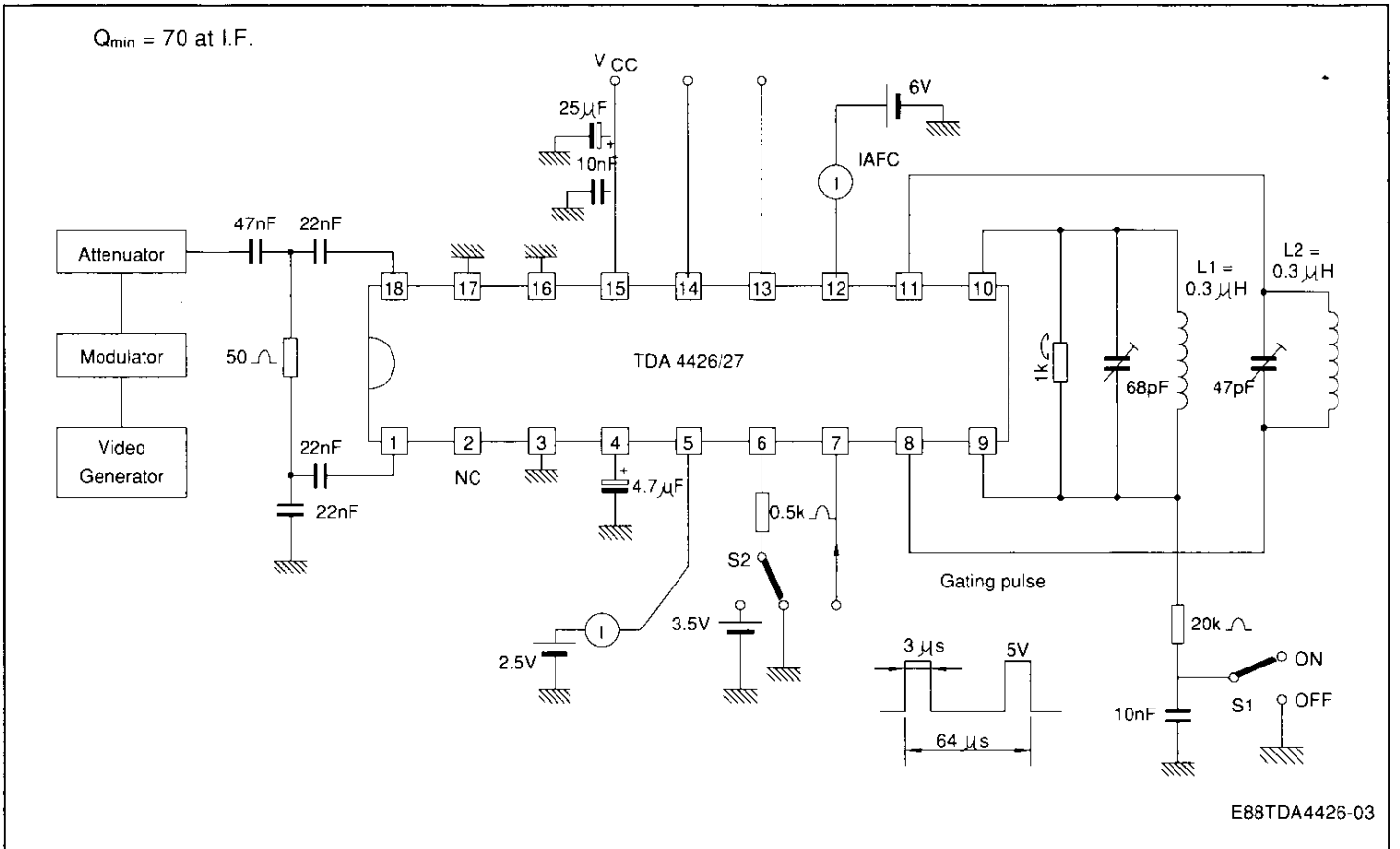

TDA4426 AFC VOLTAGE VS. INPUT FREQUENCY

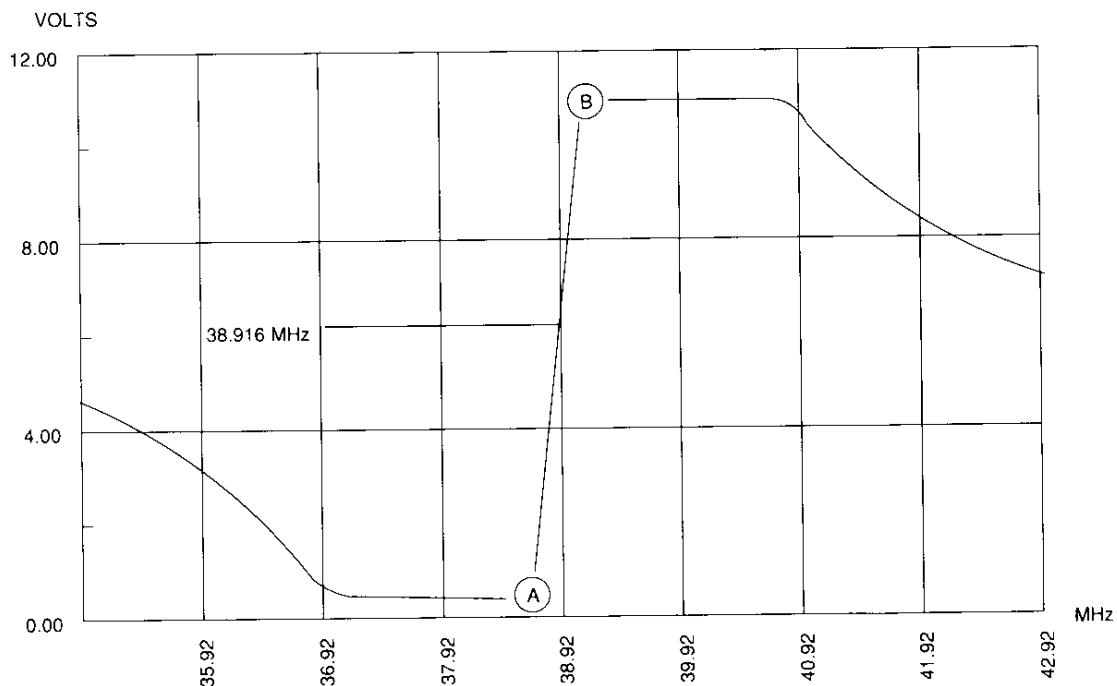

E88TDA4426-04

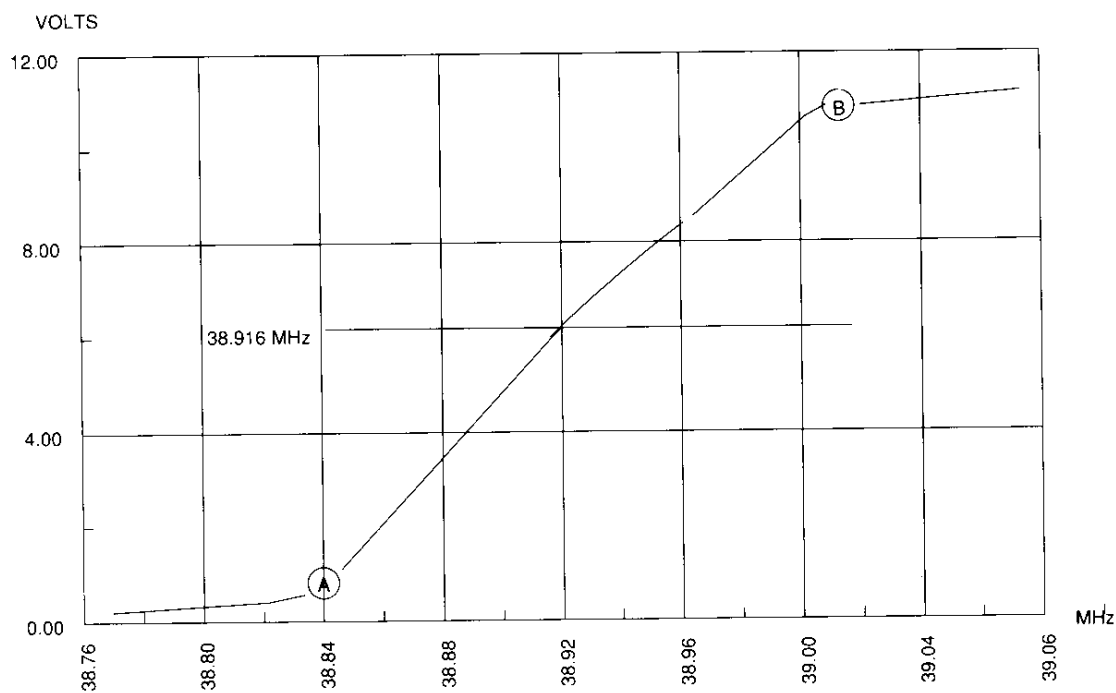

E88TDA4426-05

TDA4427 AFC VOLTAGE VS. INPUT FREQUENCY

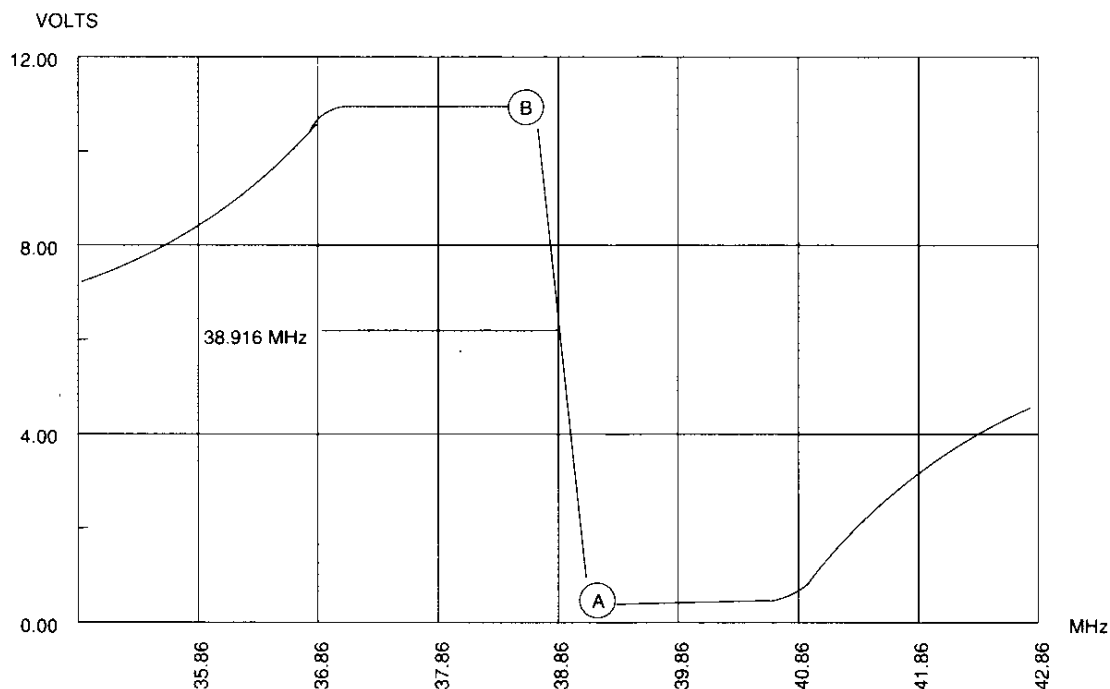

E88TDA4426-06

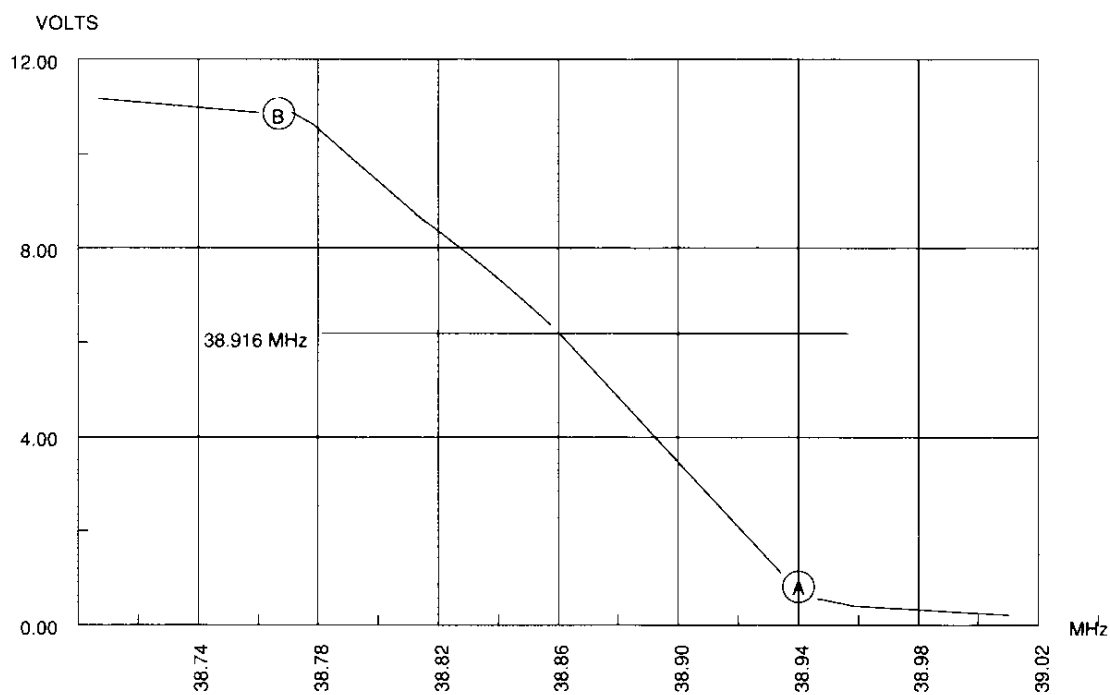

E88TDA4426-07

PACKAGE MECHANICAL DATA

18 PINS – PLASTIC DIP

