

DISPLAY Elektronik GmbH

DATA SHEET

TFT MODULE

**DEM 480272L TMH-PW-N
(C-TOUCH)**

4,3" + PCT

Product Specification

Version: 1

22.06.2016

GENERAL SPECIFICATION

MODULE NO. :

DEM 480272L TMH-PW-N(C-TOUCH)

CUSTOMER

VERSION NO.	CHANGE DESCRIPTION	DATE
0	ORIGINAL VERSION	15.06.2016
1	GENERAL SPECIFICATIONS CHANGED	22.06.2016

PREPARED BY: YH

DATE: 22.06.2016

APPROVED BY: MH

DATE: 22.06.2016

CONTENTS

1. GENERAL SPECIFICATIONS.....2

2. EXTERNAL DIMENSIONS4

3. BLOCK DIAGRAM6

4. PIN ASSIGNMENT7

5. OPTICAL CHARACTERISTICS8

6. ABSOLUTE MAXIMUM RATINGS..... 11

7. ELECTRICAL CHARACTERISTICS..... 12

8. RELIABILITY TEST 16

9. LCD MODULES HANDLING PRECAUTIONS..... 17

10. OTHERS 17

1. GENERAL SPECIFICATIONS

Item	Contents	Unit
LCD TYPE	TFT/TRANSMISSIVE	
MODULE SIZE (W*H*T)	105.50×67.20×4.30	mm
ACTIVE SIZE (W*H)	95.04*53.86	mm
PIXEL PITCH (W*H)	0.198*0.198	mm
NUMBER OF DOTS	480×RGB×272	
DIVER IC	ILI6480BQ	
INTERFACE TYPE	24-BIT/18-BIT — RGB	
TOP POLARIZER TYPE	ANTI-GLARE	
RECOMMEND VIEWING DIRECTION	12:00	O'CLOCK
GRAY SCALE INVERSION DIRECTION	6:00	O'CLOCK
COLORS	16.7 Million	
BACKLIGHT TYPE	9-DIES WHITE LED	
TOUCH PANEL TYPE	CTP	
APPROX.WEIGHT	76	g

* Note: Total Outline (incl. Cover-Glass) is 125.00 x 86.00 mm

TOUCH PANEL FEATURES:

Item	Contents
Type	Capacitive Multi-Touch
Module Size (without FPC)	125.00 x 86.00 x 1.40 mm
View Area	97.70 x 56.20 mm
Drive IC	ILI2139C (Ilitek)
Interface	I2C
Operation Voltage	2.6V ~ 3.6V
ITO Glass Thickness	0.4 mm
Operation Humidity	20~90%RH
Storage Humidity	20~90%RH
Resolution	≧ 1024x768
Input Force	≧ 10g
Input Method	Finger or exclusive Pen
Transparency	≧ 88%
Surface Hardness	>6H
Hitting Life	>35,000,000 times
Insulation	20M Ohm or over(DC 25V)
ESD (Human Body Model)	4,000 V
Application	The product is touch panels used as the input devices for General Electric Appliances and Industrial Equipment
Scope	This specification applies for Finger Input transparent Touch Panels. (Those mentioned in the individual specification shall be given priority)

2. EXTERNAL DIMENSIONS

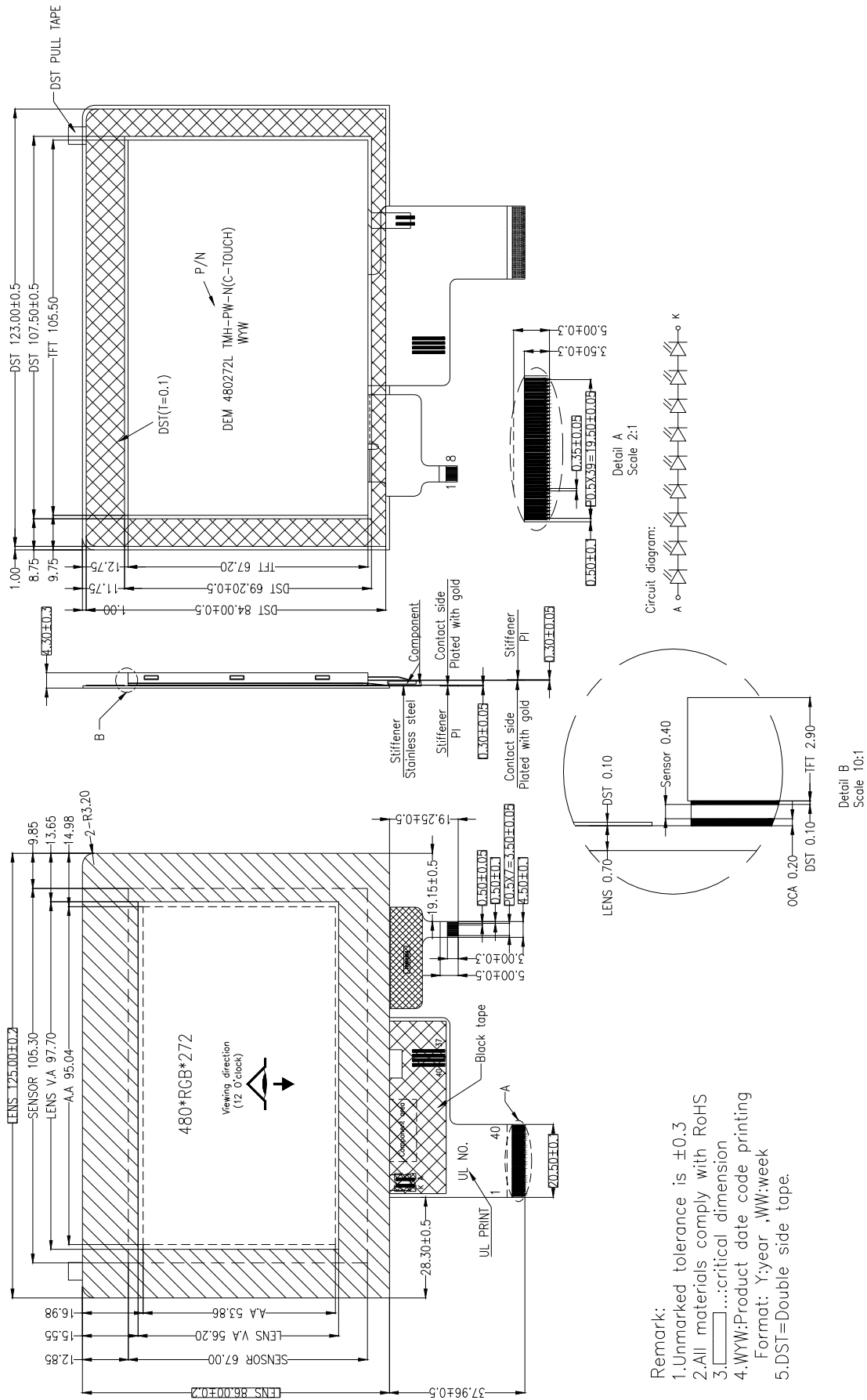

3. BLOCK DIAGRAM

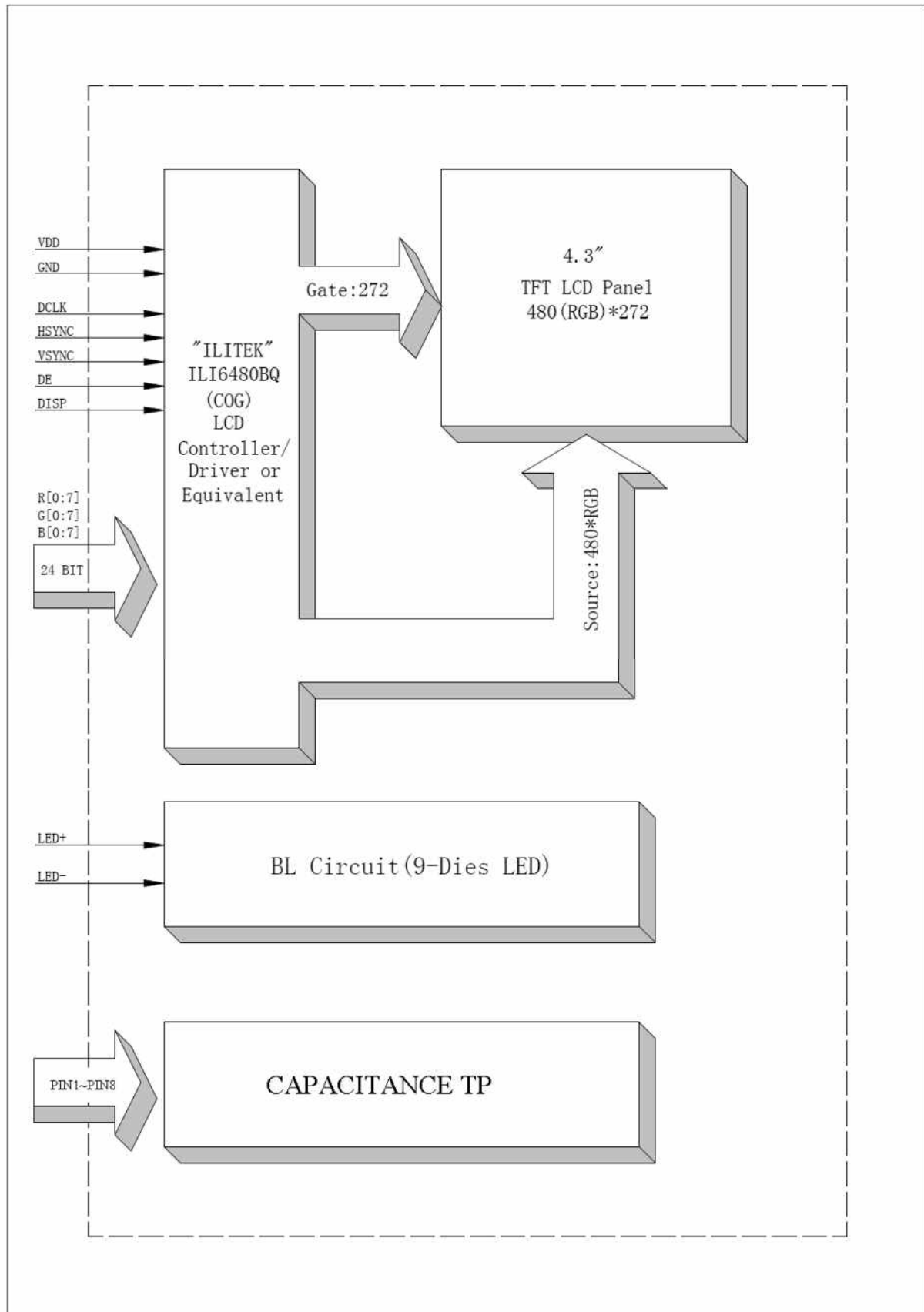

4. PIN ASSIGNMENT

Pin No.	Symbol	Description
1	LED-	Cathode of LED backlight
2	LED+	Anode of LED backlight
3	GND	Power ground
4	VDD	Power supply
5~12	R0~R7	8-bit digital Red data input,
13~20	G0~G7	8-bit digital Green data input,
21~28	B0~B7	8-bit digital Blue data input,
29	GND	Power ground
30	DCLK	Clock signal; latching data at the falling edge
31	DISP	Display control / standby mode selection. DISP – “Low” : Standby; DISP – “High” : Normal display(Default)
32	HSYNC	Horizontal sync signal; negative polarity
33	VSYNC	Vertical sync signal; negative polarity
34	DE	Data input enable. Active High to enable the data input.
35	NC	No connection.
36	GND	Power ground
37	NC	No connection.
38	NC	No connection.
39	NC	No connection.
40	NC	No connection.

Touch Panel:

Pin No.	Symbol	Description
1	INT	External Interrupt
2	GND	Negative supply
3	REST	Global reset input, low active
4	NC	No connection
5	SDA	A serial data pin for I2C interface
6	SCL	A serial clock pin for I2C interface
7	VDD	Positive power supply
8	NC	No connection

5. OPTICAL CHARACTERISTICS

ITEM	SYMBOL	CONDITIONS	SPECIFICATIONS			UNIT	NOTE	
			MIN	TYP.	MAX			
Luminance	L	$I_L - 20mA$	400	440	480	Cd/m ²		
Contrast Ratio	CR	$\theta - 0^\circ$	400	500				
Response Time CIE Color Coordinate	Red	25°C Viewing normal angle	T_{ON}	10	20	ms		
			T_{OFF}	15	30			
	Green		X_R					
			Y_R					
	Blue		X_G					
			Y_G					
	White		X_B					
			Y_B					
			X_W	0.27	0.31			0.35
	Y_W	0.31	0.35	0.39				
Viewing Angle	Hor.	$CR \geq 10$	θ_{x+}	60	70	Degree		
			θ_x	60	70			
	Ver.		θ_{y1}	40	50			
			θ_{y-}	60	70			
Uniformity	Un		80		%			

Note 1: Definition of Viewing Angle θ_x and θ_y :

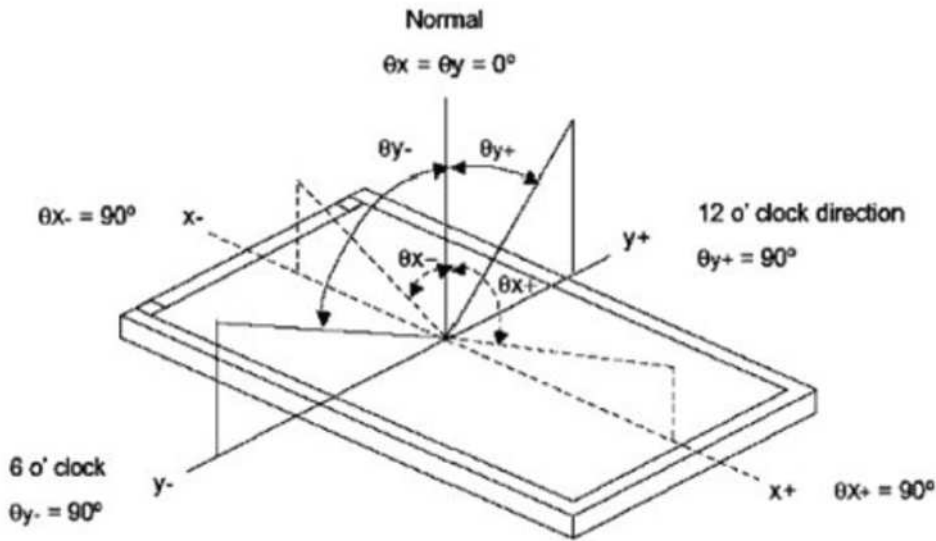

Note 2: Definition of contrast ratio CR:

$$CR = \frac{\text{Luminance of white state}}{\text{Luminance of black state}}$$

Note 3: Definition of Response Time (T_r, T_f)

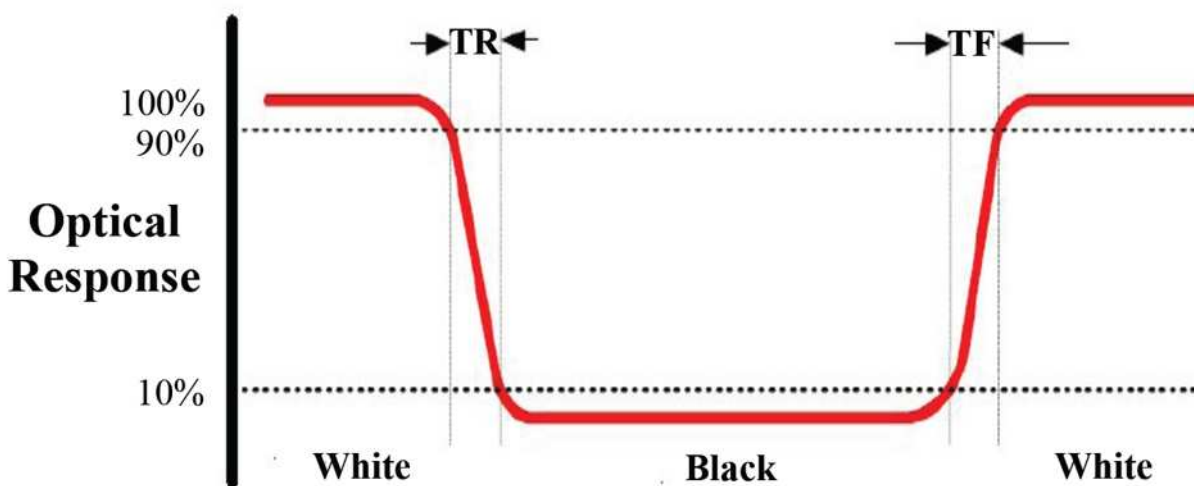

Note 4: Definition of Luminance

① The Brightness Test Equipment Setup

Field=2° (As measuring “black” image, field=2° is the best testing condition)

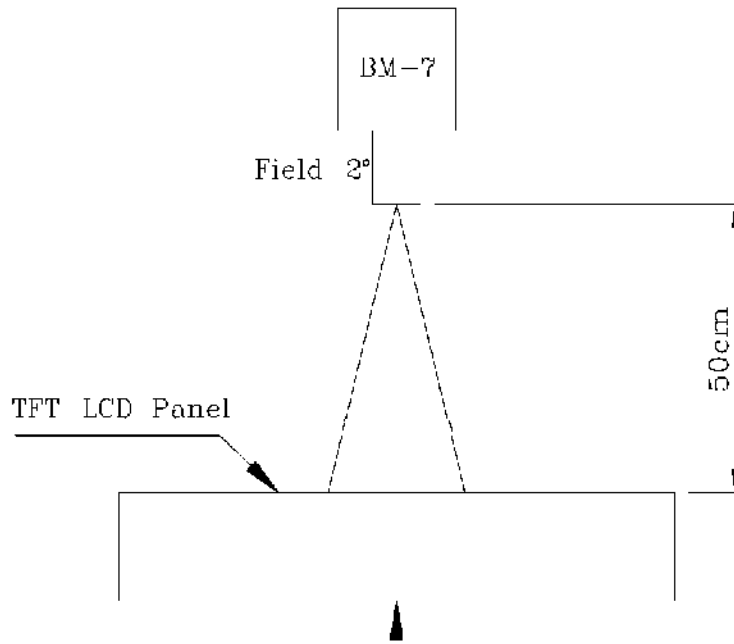

The center of the screen

② The Brightness Test Point Setup

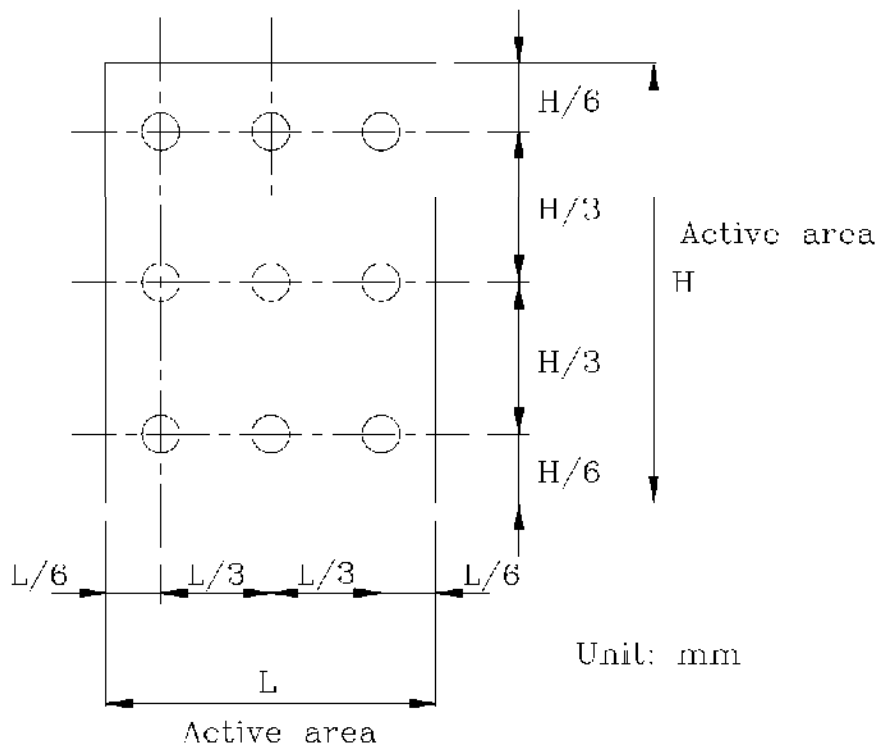

6. ABSOLUTE MAXIMUM RATINGS

Parameter	Symbol	Min	Max	Unit
Supply voltage for analog	VDD	-0.3	4.5	V
Supply voltage for logic	VDD	-0.3	4.5	V
Supply current (One LED)	I _{LED}		30	mA
Operating temperature	T _{OP}	-20	-70	°C
Storage temperature	T _{ST}	-30	-80	°C

Note : The absolute maximum rating values of this product are not allowed to be exceeded at any times. Should a module be used with any of the absolute maximum ratings exceeded, the characteristics of the module may not be recovered, or in an extreme case, the module may be permanently destroyed.

TOUCH PANEL:

Item	Symbol	Min	Max	Unit
Voltage on V _{DD} with respect to GND	VDD	-0.3	3.6	V
Operating Temperature	Topr	-40	+85	°C
Storage Temperature	Tstg	-40	+85	°C

7. ELECTRICAL CHARACTERISTICS

7.1 INPUT POWER

Item	Symbol	Min	Typ.	Max	Unit	Applicable terminal
Supply Voltage for Analog	VDD	3.0	3.3	3.6	V	
Supply Voltage for Logic	VDD	3.0	3.3	3.6	V	
Input Voltage	V _{IL} V _{IH}	GND 0.7 VCC	- -	0.3VCC VCC	V	
Input leakage Current	I _{TKG}	-1		1	μA	

7.2 BLACKLIGHT DRIVING CONDITIONS

Item	Symbol	Value			Unit	Remark
		Min.	Typ.	Max.		
Voltage for LED Backlight	V _F	27	28.8	30.6	V	I _L =20mA
Current for LED Backlight	I _L	15	20	25	mA	
Power Consumption	P		0.576		W	
LED Life Time		50,000			Hr	Note

Note: Brightness to be decreased to 50% of the initial value at ambient temperature TA=25℃

7.3 TIMING CHARACTERISTICS

7.3.1 PARALLEL RGB MODE TIMING DIAGRAM

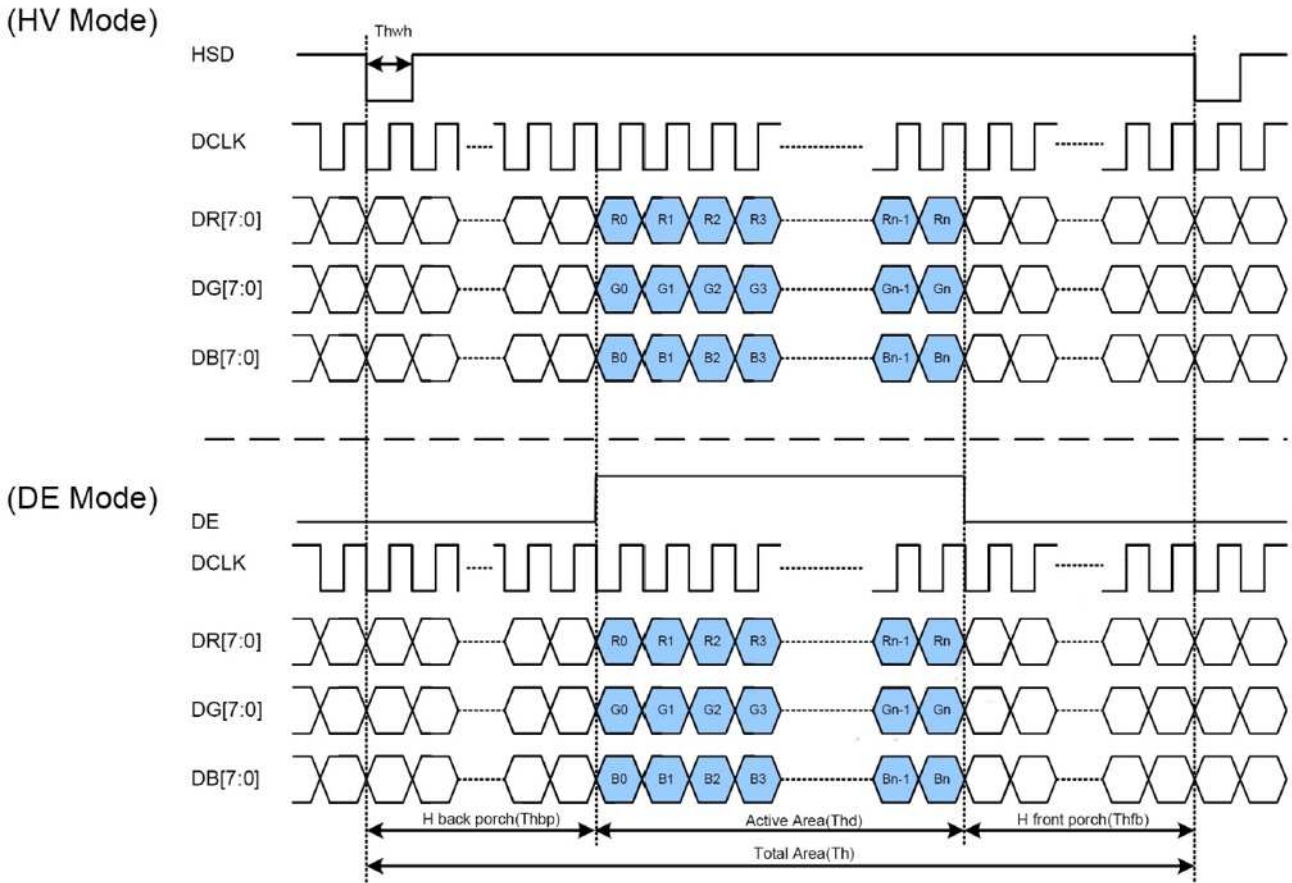

7.3.2 PARALLEL RGB TIMING TABLE

Parameter	Symbol	Value			Unit
		Min.	Typ.	Max.	
DCLK frequency	fclk	5	9	12	MHz
VSD period time	Tv	277	288	400	H
VSD display area	Tvd	272			H
VSD back porch	Tvb	3	8	31	H
VSD front porch	Tvfp	2	8	97	H
HSD period time	Th	520	525	800	DCLK
HSD display area	Thd	480			DCLK
HSD back porch	Thbp	36	40	255	DCLK
HSD front porch	Thfp	4	5	65	DCLK

7.3.3 POWER ON/OFF SEQUENCE

Power on

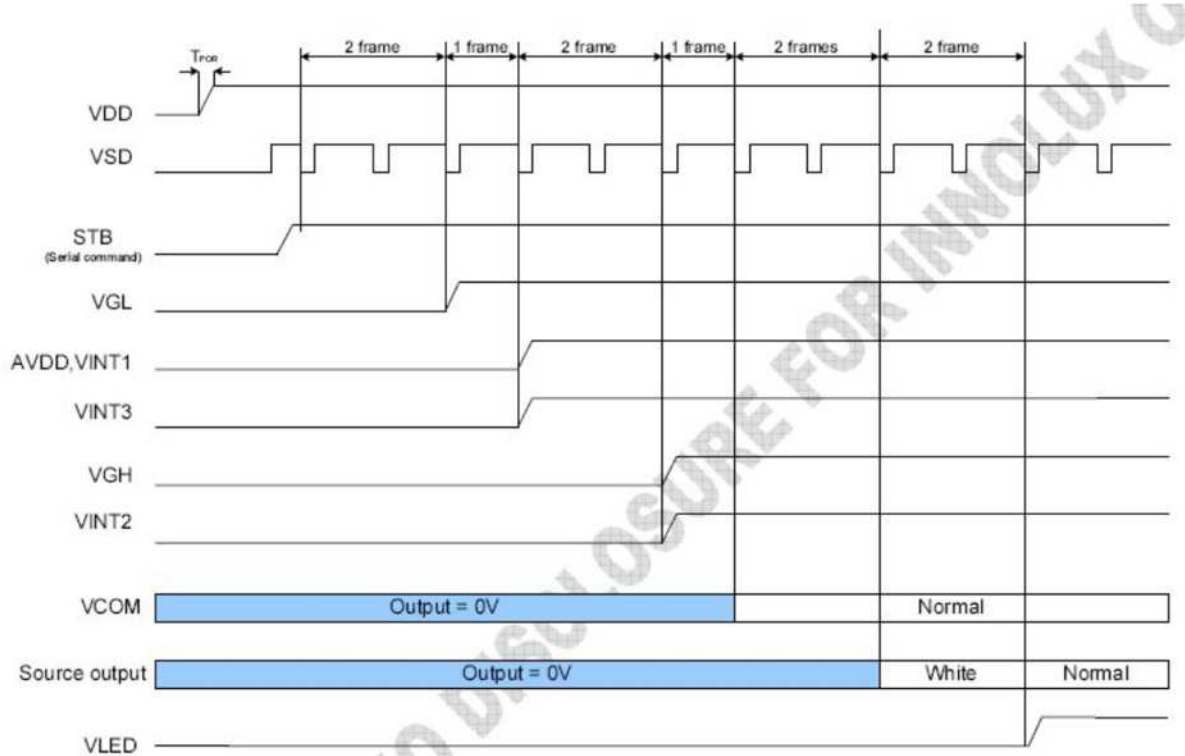

Power off

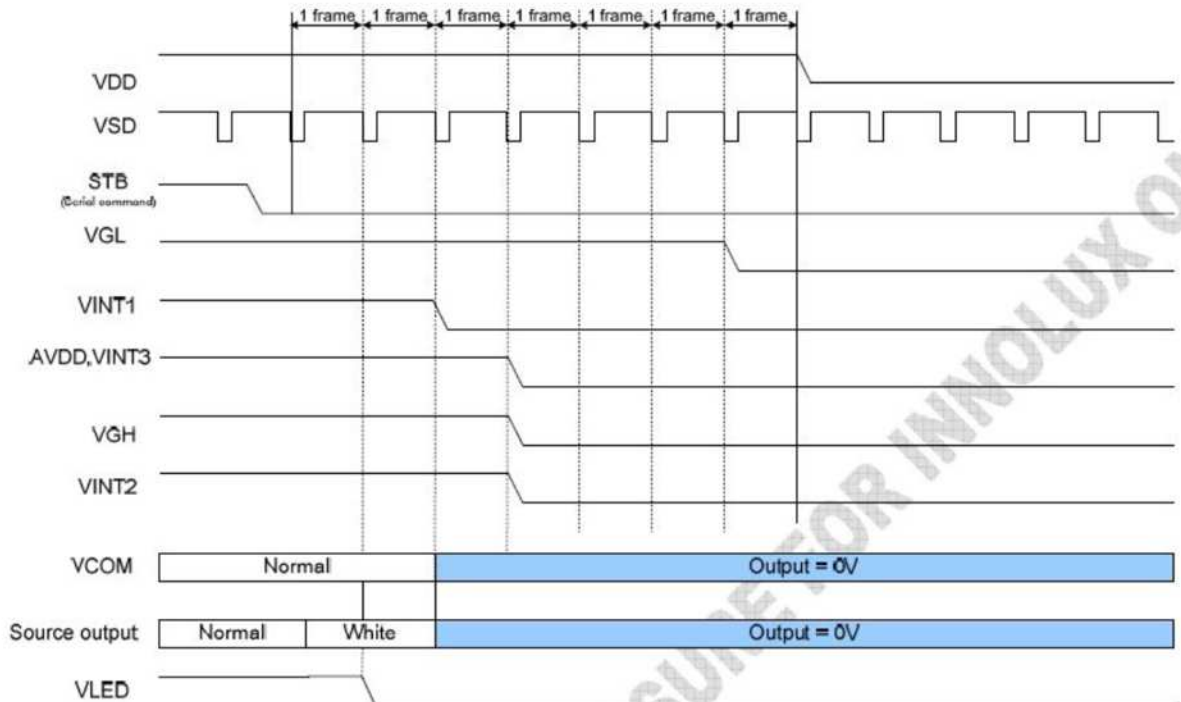

TOUCH PANEL:

DC CHARACTERISTICS

Parameter	Symbol	Min.	Typ.	Max.	Unit
Supply Voltage	VDD	2.6	3.3	3.6	V
Supply Current	IDD	---	TBD	---	mA

AC CHARACTERISTICS

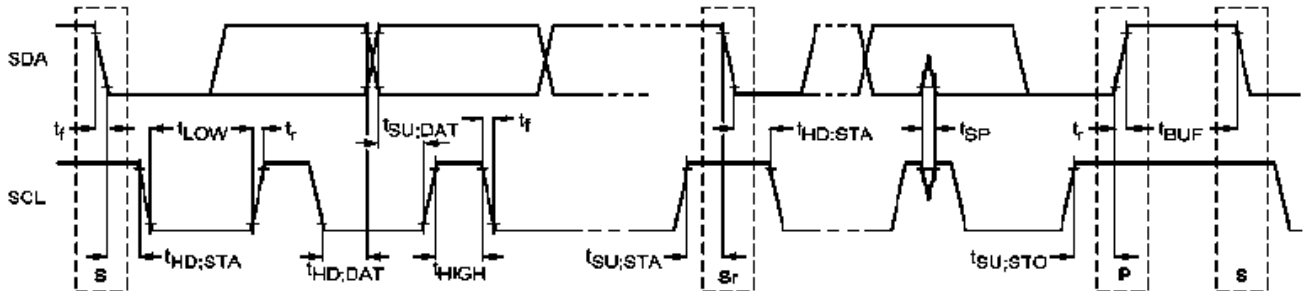

Symbol	Parameter						
		Min	Max	Unit	Min	Max	Unit
f _{SCL}	SCL clock frequency	0	100	kHz	0	400	kHz
t _{HD:STA}	Hold time (repeated) START condition. After this period, the first clock pulse is generated	4.0	–	μs	0.6	–	μs
t _{LOW}	LOW period of the SCL clock	4.7	–	μs	1.3	–	μs
t _{HIGH}	HIGH period of the SCL clock	4.0	–	μs	0.6	–	μs
t _{SU:STA}	Set-up time for a repeated START condition	4.7	–	μs	0.6	–	μs
t _{HD:DAT}	Data hold time	5.0	–	μs	0	0.9	μs
t _{SU:DAT}	Data set-up time	250	–	ns	100	–	ns
t _r	Rise time of both SDA and SCL signals	–	1000	ns	–	300	ns
t _f	Fall time of both SDA and SCL signals	–	300	ns	–	300	ns
t _{SU:STO}	Set-up time for STOP condition	4.0	–	μs	0.6	–	μs
t _{BUF}	Bus free time between a STOP and START condition	4.7	–	μs	1.3	–	μs

8. RELIABILITY TEST

No.	Item	Description
01	High temperature operation	The sample should be allowed to stand at 70°C for 120 hours under driving condition and then returning it to normal temperature condition, and allowing it stand for 2 hours.
02	Low temperature operation	The sample should be allowed to stand at -20°C for 120 hours under driving condition and then returning it to normal temperature condition, and allowing it stand for 2 hours.
03	High temperature storage	The sample should be allowed to stand at 80°C for 240 hours under no-load condition, and then returning it to normal temperature condition, and allowing it stand for 2 hours.
04	Low temperature storage	The sample should be allowed to stand at -30°C for 240 hours under no-load condition, then returning it to normal temperature condition, and allowing it stand for 2 hours.
05	Moisture storage	The sample should be allowed to stand at 60°C,90%RH MAX for 240 hours under no-load condition, then taking it out and drying it at normal temperature for 2 hours.
06	Operate at high temperature and humidity	60°C,90%RH,240hr
07	Thermal shock storage	The sample should be allowed to stand the following 10 cycles : -30°C for 30 minutes → normal temperature for 5 minutes → 80°C for 30 minutes → normal temperature for 5 minutes, as one cycle.
08	Packing vibration	Frequency range : 10Hz ~ 55Hz Amplitude of vibration : 1.5mm Sweep time: 12 min X,Y,Z 2 hours for each direction.
09	Packing drop test	According to ASTM-D-5327.
10	Electrical Static	Air: ±4KV 150pF/330Ω 5 times

9. LCD MODULES HANDLING PRECAUTIONS

- The display panel is made of glass. Do not subject it to a mechanical shock by dropping it from a high place, etc.
- If the display panel is damaged and the liquid crystal substance inside it leaks out, do not get any in your mouth. If the substance come into contact with your skin or clothes promptly wash it off using soap and water.
- Do not apply excessive force to the display surface or the adjoining areas since this may cause the color tone to vary.
- The polarizer covering the display surface of the LCD module is soft and easily scratched. Handle this polarize carefully.
- To prevent destruction of the elements by static electricity, be careful to maintain an optimum work environment.
 - Be sure to ground the body when handling the LCD module.
 - Tools required for assembly, such as soldering irons, must be properly grounded.
 - To reduce the amount of static electricity generated, do not conduct assembly and other work under dry conditions.
 - The LCD module is coated with a film to protect the display surface. Exercise care when peeling off this protective film since static electricity may be generated.
- Storage precautions
When storing the LCD modules, avoid exposure to direct sunlight or to the light of fluorescent lamps. Keep the modules in bags designed to prevent static electricity charging under low temperature / normal humidity conditions (avoid high temperature / high humidity and low temperatures below 0°C). Whenever possible, the LCD modules should be stored in the same conditions in which they were shipped from our company.

10. OTHERS

- Liquid crystals solidify at low temperature (below the storage temperature range) leading to defective orientation of liquid crystal or the generation of air bubbles (black or white). Air bubbles may also be generated if the module is subjected to a strong shock at a low temperature.
- If the LCD modules have been operating for a long time showing the same display patterns may remain on the screen as ghost images and a slight contrast irregularity may also appear. Abnormal operating status can be resumed to be normal condition by suspending use for some time. It should be noted that this phenomena does not adversely affect performance reliability.
- To minimize the performance degradation of the LCD modules resulting from caused by static electricity, etc. exercise care to avoid holding the following sections when handling the modules:
 - Exposed area of the printed circuit board
 - Terminal electrode sections.