



Figure similar

power contactor, AC-3e/AC-3, 80 A, 37 kW / 400 V, 3-pole, 21-33 V AC/DC, 50/60 Hz, with integrated varistor, auxiliary contacts: 1 NC, main circuit: screw terminal, control and auxiliary circuit: spring-loaded terminal, size: S3, F-PLC-IN

product brand name	SIRIUS
product designation	Power contactor
product type designation	3RT2
General technical data	
size of contactor	S3
product extension	
• function module for communication	No
• auxiliary switch	Yes
power loss [W] for rated value of the current	
• at AC in hot operating state	15.9 W
• at AC in hot operating state per pole	5.3 W
• without load current share typical	3.5 W
insulation voltage	
• of main circuit with degree of pollution 3 rated value	1 000 V
• of auxiliary circuit with degree of pollution 3 rated value	690 V
surge voltage resistance	
• of main circuit rated value	8 kV
• of auxiliary circuit rated value	6 kV
maximum permissible voltage for protective separation between coil and main contacts according to EN 60947-1	690 V
shock resistance at rectangular impulse	
• at AC	10.3g / 5 ms, 6.7g / 10 ms
• at DC	6.7 g / 5 ms, 4g / 10 ms
shock resistance with sine pulse	
• at AC	16.3g / 5 ms, 10.g / 10 ms
• at DC	10.6 g / 5 ms, 6.3 g / 10 ms
mechanical service life (operating cycles)	
• of contactor typical	5 000 000
• of the contactor with added electronically optimized auxiliary switch block typical	5 000 000
• of the contactor with added auxiliary switch block typical	5 000 000
reference code according to IEC 81346-2	Q
Substance Prohibitance (Date)	01/29/2021
Ambient conditions	
installation altitude at height above sea level maximum	2 000 m
ambient temperature	
• during operation	-25 ... +60 °C
• during storage	-55 ... +80 °C
relative humidity minimum	10 %
relative humidity at 55 °C according to IEC 60068-2-30	95 %

maximum	
Main circuit	
number of poles for main current circuit	3
number of NO contacts for main contacts	3
operating voltage	
• at AC-3 rated value maximum	1 000 V
• at AC-3e rated value maximum	1 000 V
operational current	
• at AC-1 at 400 V at ambient temperature 40 °C rated value	125 A
• at AC-1	
— up to 690 V at ambient temperature 40 °C rated value	125 A
— up to 690 V at ambient temperature 60 °C rated value	105 A
• at AC-3	
— at 400 V rated value	80 A
— at 500 V rated value	80 A
— at 690 V rated value	58 A
— at 1000 V rated value	30 A
• at AC-3e	
— at 400 V rated value	80 A
— at 500 V rated value	80 A
— at 690 V rated value	58 A
— at 1000 V rated value	30 A
• at AC-4 at 400 V rated value	66 A
• at AC-5a up to 690 V rated value	110 A
• at AC-5b up to 400 V rated value	80 A
• at AC-6a	
— up to 230 V for current peak value n=20 rated value	80 A
— up to 400 V for current peak value n=20 rated value	80 A
— up to 500 V for current peak value n=20 rated value	80 A
— up to 690 V for current peak value n=20 rated value	58 A
• at AC-6a	
— up to 230 V for current peak value n=30 rated value	54 A
— up to 400 V for current peak value n=30 rated value	54 A
— up to 500 V for current peak value n=30 rated value	54 A
— up to 690 V for current peak value n=30 rated value	54 A
minimum cross-section in main circuit at maximum AC-1 rated value	50 mm ²
operational current for approx. 200000 operating cycles at AC-4	
• at 400 V rated value	34 A
• at 690 V rated value	24 A
operational current	
• at 1 current path at DC-1	
— at 24 V rated value	100 A
— at 60 V rated value	60 A
— at 110 V rated value	9 A
— at 220 V rated value	2 A
— at 440 V rated value	0.6 A
— at 600 V rated value	0.4 A
• with 2 current paths in series at DC-1	
— at 24 V rated value	100 A
— at 60 V rated value	100 A
— at 110 V rated value	100 A
— at 220 V rated value	10 A
— at 440 V rated value	1.8 A
— at 600 V rated value	1 A
• with 3 current paths in series at DC-1	
— at 24 V rated value	100 A
— at 60 V rated value	100 A

<ul style="list-style-type: none"> — at 110 V rated value — at 220 V rated value — at 440 V rated value — at 600 V rated value 	100 A 80 A 4.5 A 2.6 A
<ul style="list-style-type: none"> ● at 1 current path at DC-3 at DC-5 <ul style="list-style-type: none"> — at 24 V rated value — at 60 V rated value — at 110 V rated value — at 220 V rated value — at 440 V rated value — at 600 V rated value 	40 A 6 A 2.5 A 1 A 0.15 A 0.06 A
<ul style="list-style-type: none"> ● with 2 current paths in series at DC-3 at DC-5 <ul style="list-style-type: none"> — at 24 V rated value — at 60 V rated value — at 110 V rated value — at 220 V rated value — at 440 V rated value — at 600 V rated value 	100 A 100 A 100 A 7 A 0.42 A 0.16 A
<ul style="list-style-type: none"> ● with 3 current paths in series at DC-3 at DC-5 <ul style="list-style-type: none"> — at 24 V rated value — at 60 V rated value — at 110 V rated value — at 220 V rated value — at 440 V rated value — at 600 V rated value 	100 A 100 A 100 A 35 A 0.8 A 0.35 A
operating power <ul style="list-style-type: none"> ● at AC-2 at 400 V rated value ● at AC-3 <ul style="list-style-type: none"> — at 230 V rated value — at 400 V rated value — at 500 V rated value — at 690 V rated value — at 1000 V rated value ● at AC-3e <ul style="list-style-type: none"> — at 230 V rated value — at 400 V rated value — at 500 V rated value — at 690 V rated value — at 1000 V rated value 	37 kW 22 kW 37 kW 45 kW 55 kW 37 kW 22 kW 37 kW 45 kW 55 kW 37 kW
operating power for approx. 200000 operating cycles at AC-4 <ul style="list-style-type: none"> ● at 400 V rated value ● at 690 V rated value 	17.9 kW 21.8 kW
operating apparent power at AC-6a <ul style="list-style-type: none"> ● up to 400 V for current peak value n=20 rated value ● up to 500 V for current peak value n=20 rated value ● up to 690 V for current peak value n=20 rated value 	55 000 VA 69 000 VA 69 000 VA
operating apparent power at AC-6a <ul style="list-style-type: none"> ● up to 230 V for current peak value n=30 rated value ● up to 400 V for current peak value n=30 rated value ● up to 500 V for current peak value n=30 rated value ● up to 690 V for current peak value n=30 rated value 	21 500 VA 37 400 VA 46 700 VA 64 500 VA
short-time withstand current in cold operating state up to 40 °C <ul style="list-style-type: none"> ● limited to 1 s switching at zero current maximum ● limited to 5 s switching at zero current maximum ● limited to 10 s switching at zero current maximum ● limited to 30 s switching at zero current maximum ● limited to 60 s switching at zero current maximum 	1 500 A; Use minimum cross-section acc. to AC-1 rated value 1 186 A; Use minimum cross-section acc. to AC-1 rated value 851 A; Use minimum cross-section acc. to AC-1 rated value 538 A; Use minimum cross-section acc. to AC-1 rated value 423 A; Use minimum cross-section acc. to AC-1 rated value
no-load switching frequency <ul style="list-style-type: none"> ● at AC 	1 000 1/h

<ul style="list-style-type: none"> • at DC 	1 000 1/h
operating frequency	
<ul style="list-style-type: none"> • at AC-1 maximum 	900 1/h
<ul style="list-style-type: none"> • at AC-2 maximum 	400 1/h
<ul style="list-style-type: none"> • at AC-3 maximum 	1 000 1/h
<ul style="list-style-type: none"> • at AC-3e maximum 	1 000 1/h
<ul style="list-style-type: none"> • at AC-4 maximum 	300 1/h
Control circuit/ Control	
type of voltage of the control supply voltage	AC/DC
control supply voltage at AC	
<ul style="list-style-type: none"> • at 50 Hz rated value 	21 ... 33 V
<ul style="list-style-type: none"> • at 60 Hz rated value 	21 ... 33 V
control supply voltage at DC	
<ul style="list-style-type: none"> • rated value 	21 ... 33 V
operating range factor control supply voltage rated value of magnet coil at DC	
<ul style="list-style-type: none"> • initial value 	0.8
<ul style="list-style-type: none"> • full-scale value 	1.1
operating range factor control supply voltage rated value of magnet coil at AC	
<ul style="list-style-type: none"> • at 50 Hz 	0.8 ... 1.1
<ul style="list-style-type: none"> • at 60 Hz 	0.8 ... 1.1
type of PLC-control input according to IEC 60947-1	Type 1
consumed current at PLC-control input according to IEC 60947-1 maximum	11 mA
voltage at PLC-control input rated value	24 V
operating range factor of the voltage at PLC-control input	0.8 ... 1.1
design of the surge suppressor	with varistor
inrush current peak	2.2 A
duration of inrush current peak	100 µs
locked-rotor current mean value	4 A
locked-rotor current peak	6.5 A
duration of locked-rotor current	150 ms
holding current mean value	0.09 A
apparent pick-up power of magnet coil at AC	
<ul style="list-style-type: none"> • at 50 Hz 	130 VA
<ul style="list-style-type: none"> • at 60 Hz 	130 VA
apparent holding power of magnet coil at AC	
<ul style="list-style-type: none"> • at 50 Hz 	2.4 VA
<ul style="list-style-type: none"> • at 60 Hz 	2.4 VA
closing power of magnet coil at DC	130 W
holding power of magnet coil at DC	1.8 W
closing delay	
<ul style="list-style-type: none"> • at AC 	50 ... 70 ms
<ul style="list-style-type: none"> • at DC 	50 ... 70 ms
opening delay	
<ul style="list-style-type: none"> • at AC 	38 ... 57 ms
<ul style="list-style-type: none"> • at DC 	38 ... 57 ms
recovery time after power failure typical	2.1 s
arcing time	10 ... 20 ms
control version of the switch operating mechanism	Fail-safe PLC input (F-PLC-IN)
Auxiliary circuit	
number of NC contacts for auxiliary contacts instantaneous contact	1
number of NO contacts for auxiliary contacts instantaneous contact	0
operational current at AC-12 maximum	10 A
operational current at AC-15	
<ul style="list-style-type: none"> • at 230 V rated value 	6 A
<ul style="list-style-type: none"> • at 400 V rated value 	3 A
<ul style="list-style-type: none"> • at 500 V rated value 	2 A
<ul style="list-style-type: none"> • at 690 V rated value 	1 A

operational current at DC-12	
<ul style="list-style-type: none"> ● at 24 V rated value ● at 48 V rated value ● at 60 V rated value ● at 110 V rated value ● at 125 V rated value ● at 220 V rated value ● at 600 V rated value 	10 A 6 A 6 A 3 A 2 A 1 A 0.15 A
operational current at DC-13	
<ul style="list-style-type: none"> ● at 24 V rated value ● at 48 V rated value ● at 60 V rated value ● at 110 V rated value ● at 125 V rated value ● at 220 V rated value ● at 600 V rated value 	10 A 2 A 2 A 1 A 0.9 A 0.3 A 0.1 A
contact reliability of auxiliary contacts	1 faulty switching per 100 million (17 V, 1 mA)
UL/CSA ratings	
full-load current (FLA) for 3-phase AC motor	
<ul style="list-style-type: none"> ● at 480 V rated value ● at 600 V rated value 	77 A 62 A
yielded mechanical performance [hp]	
<ul style="list-style-type: none"> ● for single-phase AC motor <ul style="list-style-type: none"> — at 110/120 V rated value — at 230 V rated value ● for 3-phase AC motor <ul style="list-style-type: none"> — at 200/208 V rated value — at 220/230 V rated value — at 460/480 V rated value — at 575/600 V rated value 	7.5 hp 15 hp 25 hp 30 hp 60 hp 60 hp
contact rating of auxiliary contacts according to UL	A600 / P600
Short-circuit protection	
design of the fuse link	
<ul style="list-style-type: none"> ● for short-circuit protection of the main circuit <ul style="list-style-type: none"> — with type of coordination 1 required — with type of assignment 2 required ● for short-circuit protection of the auxiliary switch required 	gG: 250 A (690 V, 100 kA), aM: 160 A (690 V, 100 kA), BS88: 200 A (415 V, 80 kA) gG: 160A (690V,100kA), aM: 80A (690V,100kA), BS88: 125A (415V,80kA) gG: 10 A (500 V, 1 kA)
Installation/ mounting/ dimensions	
mounting position	+/-180° rotation possible on vertical mounting surface; can be tilted forward and backward by +/- 22.5° on vertical mounting surface
fastening method	screw and snap-on mounting onto 35 mm DIN rail according to DIN EN 60715
<ul style="list-style-type: none"> ● side-by-side mounting 	Yes
height	140 mm
width	70 mm
depth	152 mm
required spacing	
<ul style="list-style-type: none"> ● with side-by-side mounting <ul style="list-style-type: none"> — forwards — upwards — downwards — at the side ● for grounded parts <ul style="list-style-type: none"> — forwards — upwards — at the side — downwards ● for live parts <ul style="list-style-type: none"> — forwards — upwards — downwards 	20 mm 10 mm 10 mm 0 mm 20 mm 10 mm 10 mm 10 mm 20 mm 10 mm 10 mm

— at the side

10 mm

Connections/ Terminals

type of electrical connection <ul style="list-style-type: none"> • for main current circuit • for auxiliary and control circuit • at contactor for auxiliary contacts • of magnet coil 	screw-type terminals spring-loaded terminals Spring-type terminals Spring-type terminals
type of connectable conductor cross-sections for main contacts <ul style="list-style-type: none"> • finely stranded with core end processing 	2x (2.5 ... 35 mm ²), 1x (2.5 ... 50 mm ²)
connectable conductor cross-section for main contacts <ul style="list-style-type: none"> • solid • stranded • finely stranded with core end processing 	2.5 ... 16 mm ² 6 ... 70 mm ² 2.5 ... 50 mm ²
connectable conductor cross-section for auxiliary contacts <ul style="list-style-type: none"> • solid or stranded • finely stranded with core end processing • finely stranded without core end processing 	0.5 ... 2.5 mm ² 0.5 ... 2.5 mm ² 0.5 ... 2.5 mm ²
type of connectable conductor cross-sections <ul style="list-style-type: none"> • for auxiliary contacts <ul style="list-style-type: none"> — solid or stranded — finely stranded with core end processing — finely stranded without core end processing • for AWG cables for auxiliary contacts 	2x (0.5 ... 2.5 mm ²) 2x (0.5 ... 1.5 mm ²) 2x (0.5 ... 2.5 mm ²) 2x (20 ... 16)
AWG number as coded connectable conductor cross section <ul style="list-style-type: none"> • for main contacts • for auxiliary contacts 	10 ... 2 20 ... 14

Safety related data

product function <ul style="list-style-type: none"> • mirror contact according to IEC 60947-4-1 • positively driven operation according to IEC 60947-5-1 	Yes No
safety device type according to IEC 61508-2	Type B
B10 value with high demand rate according to SN 31920	1 000 000
Safety Integrity Level (SIL) according to IEC 61508	2
SIL Claim Limit (subsystem) according to EN 62061	2
performance level (PL) according to EN ISO 13849-1	c
category according to EN ISO 13849-1	2
stop category according to EN 60204-1	0
Safe failure fraction (SFF)	96 %
diagnostics test interval by internal test function maximum	28 800 s
proportion of dangerous failures <ul style="list-style-type: none"> • with low demand rate according to SN 31920 • with high demand rate according to SN 31920 	40 % 73 %
failure rate [FIT] with low demand rate according to SN 31920	100 FIT
PFHD with high demand rate according to EN 62061	7.7E-8 1/h
PFDavg with low demand rate according to IEC 61508	0.0067
MTBF	52 a
hardware fault tolerance according to IEC 61508	0
T1 value for proof test interval or service life according to IEC 61508	20 a
protection class IP on the front according to IEC 60529	IP20
touch protection on the front according to IEC 60529	finger-safe, for vertical contact from the front
suitability for use <ul style="list-style-type: none"> • safety-related switching on • safety-related switching OFF 	No Yes

Certificates/ approvals

General Product Approval



[Confirmation](#)



[KC](#)



EMC	Functional Safety/Safety of Machinery	Declaration of Conformity	Test Certificates		
-----	---------------------------------------	---------------------------	-------------------	--	--



[Type Examination Certificate](#)



[Special Test Certificate](#)

[Type Test Certificates/Test Report](#)

Marine / Shipping	other			Railway
-------------------	-------	--	--	---------



[Confirmation](#)

[Vibration and Shock](#)

Further information

Siemens has decided to exit the Russian market (see here).

<https://press.siemens.com/global/en/pressrelease/siemens-wind-down-russian-business>

Siemens is working on the renewal of the current EAC certificates.

Please contact your local Siemens office on the status of validity of the EAC certification if you intend to import or offer to supply these products to an EAC relevant market (other than the sanctioned EAEU member states Russia or Belarus).

Information on the packaging

<https://support.industry.siemens.com/cs/ww/en/view/109813875>

Information- and Downloadcenter (Catalogs, Brochures,...)

<https://www.siemens.com/ic10>

Industry Mall (Online ordering system)

<https://mall.industry.siemens.com/mall/en/en/Catalog/product?mlfb=3RT2045-3SB30>

Cax online generator

<http://support.automation.siemens.com/WWW/CAXorder/default.aspx?lang=en&mlfb=3RT2045-3SB30>

Service&Support (Manuals, Certificates, Characteristics, FAQs,...)

<https://support.industry.siemens.com/cs/ww/en/ps/3RT2045-3SB30>

Image database (product images, 2D dimension drawings, 3D models, device circuit diagrams, EPLAN macros, ...)

http://www.automation.siemens.com/bilddb/cax_de.aspx?mlfb=3RT2045-3SB30&lang=en

Characteristic: Tripping characteristics, I²t, Let-through current

<https://support.industry.siemens.com/cs/ww/en/ps/3RT2045-3SB30/char>

Further characteristics (e.g. electrical endurance, switching frequency)

<http://www.automation.siemens.com/bilddb/index.aspx?view=Search&mlfb=3RT2045-3SB30&objecttype=14&gridview=view1>

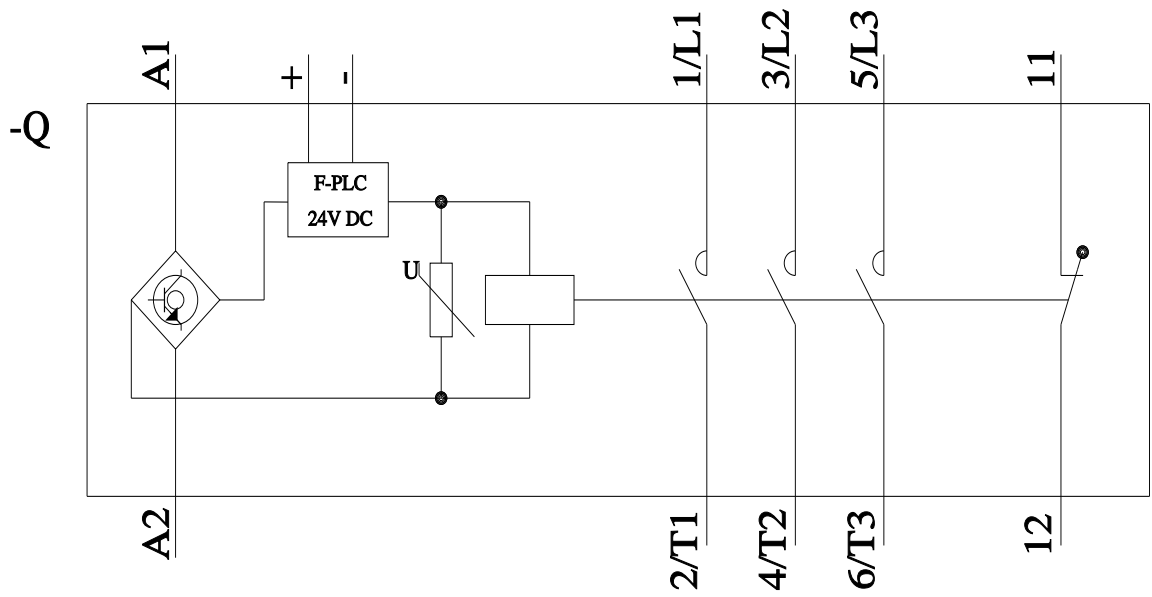
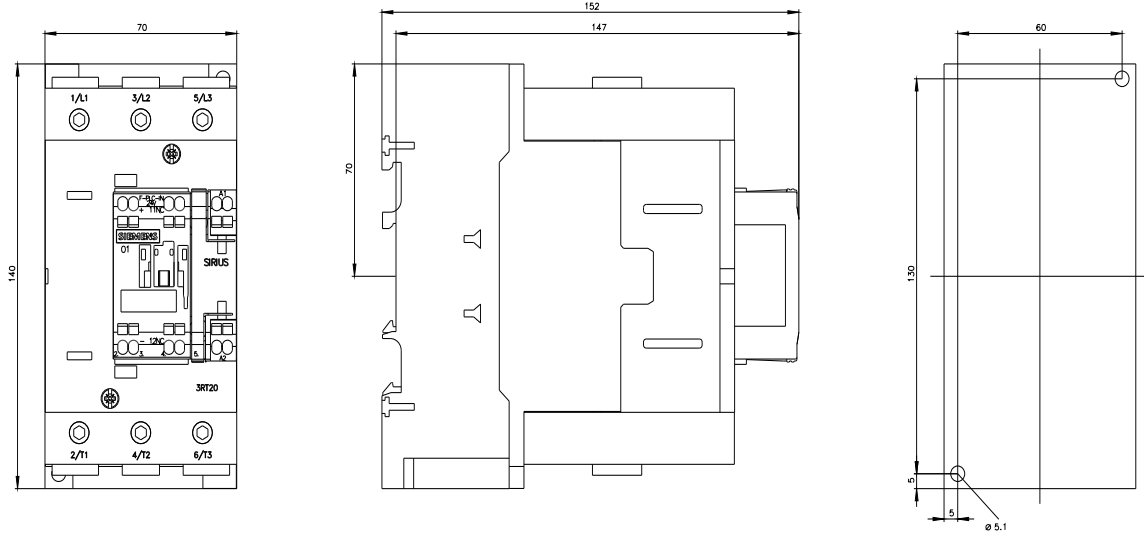

last modified:

2/10/2023

