

Product Data Sheet 3314 N/2H3P

**ebmpapst**

The engineer's choice



**3314 N/2H3P**

**INDEX**

|          |                                    |           |
|----------|------------------------------------|-----------|
| <b>1</b> | <b>General</b> .....               | <b>3</b>  |
| <b>2</b> | <b>Mechanics</b> .....             | <b>3</b>  |
| 2.1      | General.....                       | 3         |
| 2.2      | Connections.....                   | 3         |
| <b>3</b> | <b>Operating Data</b> .....        | <b>4</b>  |
| 3.1      | Electrical Interface - Input.....  | 4         |
| 3.2      | Electrical Operating Data .....    | 5         |
| 3.3      | Electrical Interface - Output..... | 6         |
| 3.4      | Electrical Features .....          | 6         |
| 3.5      | Aerodynamics.....                  | 8         |
| 3.6      | Sound Data.....                    | 10        |
| <b>4</b> | <b>Environment</b> .....           | <b>10</b> |
| 4.1      | General.....                       | 10        |
| 4.2      | Climatic Requirements .....        | 10        |
| 4.3      | Mechanical Requirements.....       | 10        |
| <b>5</b> | <b>Safety</b> .....                | <b>12</b> |
| 5.1      | Electrical Safety .....            | 12        |
| 5.2      | Approval Tests.....                | 12        |
| <b>6</b> | <b>Reliability</b> .....           | <b>12</b> |
| 6.1      | General.....                       | 12        |

## 1 General

|                                     |                        |  |
|-------------------------------------|------------------------|--|
| Fan type                            | Fan                    |  |
| Rotating direction looking at rotor | Clockwise              |  |
| Airflow direction                   | Air outlet over struts |  |
| Bearing system                      | Ball bearing           |  |
| Mounting position - shaft           | Any                    |  |

## 2 Mechanics

### 2.1 General

|   |   |  |
|---|---|--|
| Width   | 92,0 mm   |  |
| Height  | 92,0 mm   |  |
| Depth   | 32 mm   |  |
| Mass  | 0,19 kg   |  |
| Housing material                                      | Plastic   |  |
| Impeller material                                     | Plastic   |  |
| Max. torque when mounted across both mounting flanges | Wire outlet corner: 80 Ncm<br>Remaining corners: 80 Ncm                 |  |
| Screw size  | ISO 4762 - M4 degreased, without an additional brace and without washer |  |

### 2.2 Connections

|                       |             |  |
|-----------------------|-------------|--|
| Electrical connection | Wires       |  |
| Lead wire length      | L = 310 mm  |  |
| Tolerance             | + - 10,0 mm |  |
| Wire size (AWG)       |             |  |
| Insulation diameter   | 1,5 mm      |  |

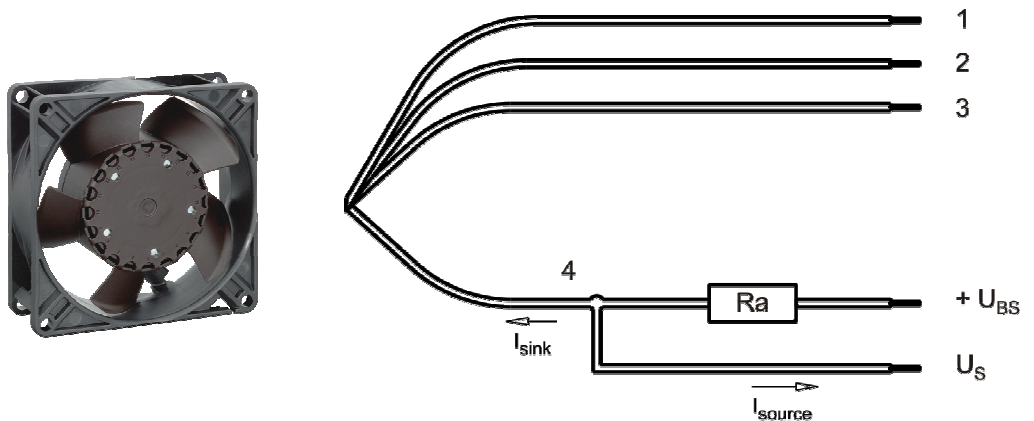

| Wire | Color  | Operation | Wire size | Insulation diameter |
|------|--------|-----------|-----------|---------------------|
| 1    | red    | + UB      | AWG 24    |                     |
| 2    | blue   | - GND     | AWG 24    |                     |
| 3    | violet | PWM       | AWG 24    |                     |
| 4    | white  | PWM       | AWG 24    |                     |

3 Operating Data

3.1 Electrical Interface - Input

|               |     |
|---------------|-----|
| Control input | PWM |
|---------------|-----|

Features

|                                 |                       |                                   |
|---------------------------------|-----------------------|-----------------------------------|
| Inpute type                     | Open collector        |                                   |
| PWM - Frequency                 |                       | 1 kHz - 30 kHz<br>typical: 25 kHz |
| Max. voltage for logic "Low"    |                       | 0,2 V                             |
| Maximum source current          | short circuit current | <= 1 mA                           |
| Typical time until warm restart | After shutdown by PWM | ~ 9 s                             |

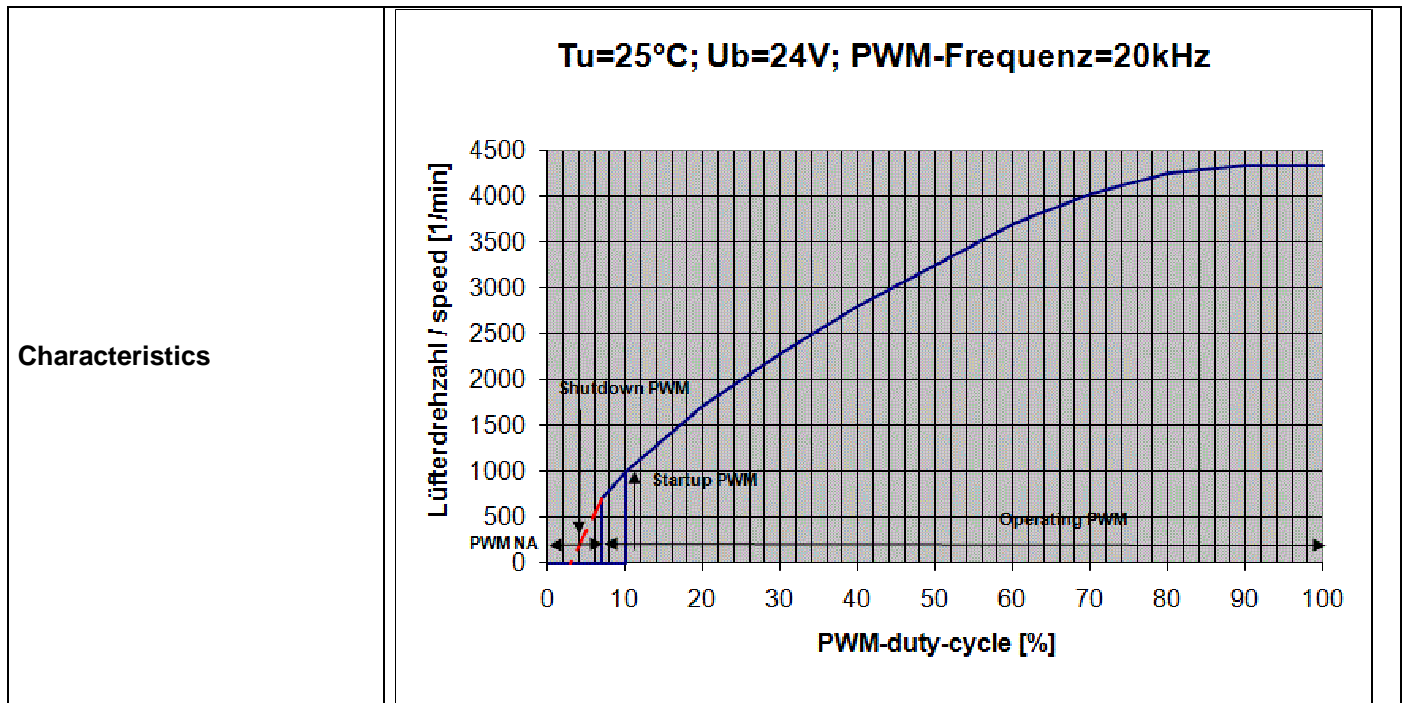

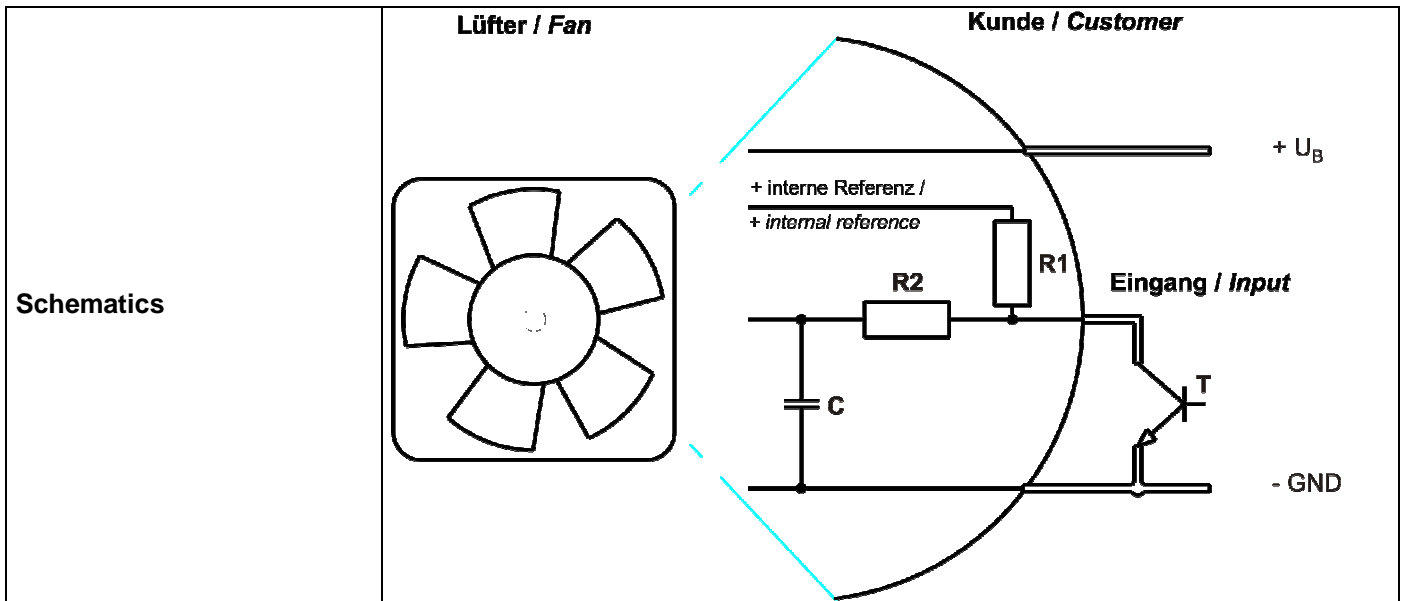

### 3.2 Electrical Operating Data

Measurement conditions: Normal air density = 1,2 kg/m<sup>3</sup>; Temperature 23°C +/- 3°C; Motor axis horizontal; warm-up time before measuring 5 minutes (unless otherwise specified). In the intake and outlet area should not be any solid obstruction within 0,5 m.

$\Delta p = 0$ : corresp. to free air flow (see chapter aerodynamics)  
 I: corresp. to arithm. mean current value

| Name     | Condition                                    |
|----------|--|
| PWM 0001 | PWM: 100 %; f: 25 kHz   f: 1 kHz   f: 30 kHz |

| Features                     | Condition      | Symbol | Values      |             |             |
|------------------------------|----------------|--------|-------------|-------------|-------------|
| Voltage range                |                | U      | 14 V        |             | 26,4 V      |
| Nominal voltage              |                | $U_N$  |             | 24 V        |             |
| Power consumption            | $\Delta p = 0$ | P      | 1,7 W       | 5,5 W       | 7,1 W       |
| Tolerance                    | PWM 0010       |        | +/- 20 %    | +/- 15 %    | +/- 15 %    |
| Current consumption          | $\Delta p = 0$ | I      | 55 mA       | 230 mA      | 270 mA      |
| Tolerance                    | PWM 0010       |        | +/- 17,5 %  | +/- 15 %    | +/- 15 %    |
| Speed                        | $\Delta p = 0$ | n      | 2.000 1/min | 4.350 1/min | 4.650 1/min |
| Tolerance                    | PWM 0010       |        | +/- 12,5 %  | +/- 10 %    | +/- 10 %    |
| Starting current consumption |                |        |             | <= 600 mA   |             |

### 3.3 Electrical Interface - Output

|            |                     |
|------------|---------------------|
| Tacho type | /2 (open collector) |
|------------|---------------------|



| Features                  | Note   | Values                        |
|---------------------------|--|-------------------------------|
| Tacho operating voltage   | $U_{BS}$   | $\leq 60\text{ V}$            |
| Tacho signal Low          | $U_{S\ low}$   | $\leq 0,4\text{ V}$           |
| Tacho signal High         | $U_{S\ high}$  | $60\text{ V}$                 |
| Maximum sink current      | $I_{sink}$   | $\leq 4\text{ mA}$            |
| External resistor         | External resistor $R_a$ from $U_{BS}$ to $U_S$ required. All voltages measured to GND. |                               |
| Tacho frequency           | $(2 \times n) / 60$  |                               |
| Tacho isolated from motor | No   |                               |
| Slew rate                 |  | $\Rightarrow 0,5\text{ V/us}$ |

$n$  = revolutions per minute (1/min)

### 3.4 Electrical Features

|                                |  |  |
|--------------------------------|--|--|
| Electronic function            | Speed-Controlled                               |  |
| Reversed polarity protection   | Rectifying diode                               |  |
| Max. residual current at $U_N$ | $I_F < 200\text{ uA}$                          |  |
| Locked rotor protection        | Auto restart                                   |  |
| Locked rotor current at $U_N$  | $I_{block}$ approx. $950\text{ mA}$            |  |
| Clock signal at locked rotor   | $t_3 / t_4$ typical: $1\text{ s} / 9\text{ s}$ |  |

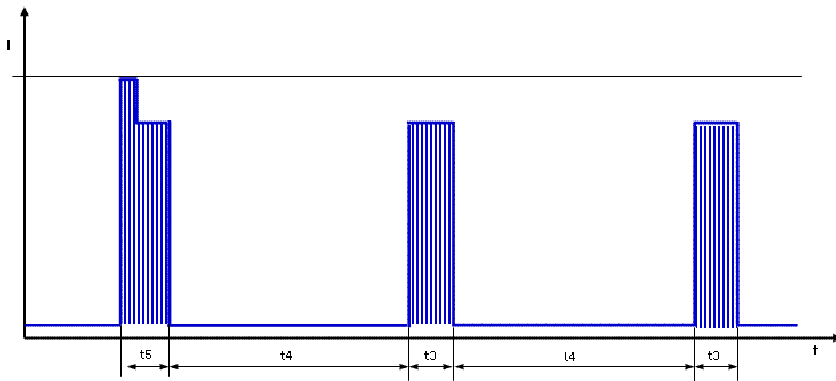

First pulse  $t_5$  typical 1,6s (1,3 .. 1,9s) followed by  $t_4$ . Afterwards cyclical  $t_3/t_4$ .

### 3.5 Aerodynamics

Measurement conditions:

Measured with a double chamber intake rig acc. to DIN EN ISO 5801.

Normal air density = 1,2 kg/m<sup>3</sup>; Temperature 23°C +/- 3°C;

In the intake and outlet area should not be any solid obstruction within 0,5 m. Motor shaft horizontal.

The information is only valid under the specified test conditions and may be changed by the installation conditions. If there are deviations from the standard test conditions, the characteristic values must be checked under the installed conditions.

a.) Operation condition:

|                              |                      |          |           |
|------------------------------|----------------------|----------|-----------|
| 4.350 1/min at free air flow | PWM 100 %; f: 25 kHz | f: 1 kHz | f: 30 kHz |
|------------------------------|----------------------|----------|-----------|

|   |                       |
|---|-----------------------|
| Max. free-air flow ( $\Delta p = 0 / \dot{V} = \text{max.}$ )   | 133 m <sup>3</sup> /h |
| Max. static pressure ( $\Delta p = \text{max.} / \dot{V} = 0$ ) | 130 Pa                |

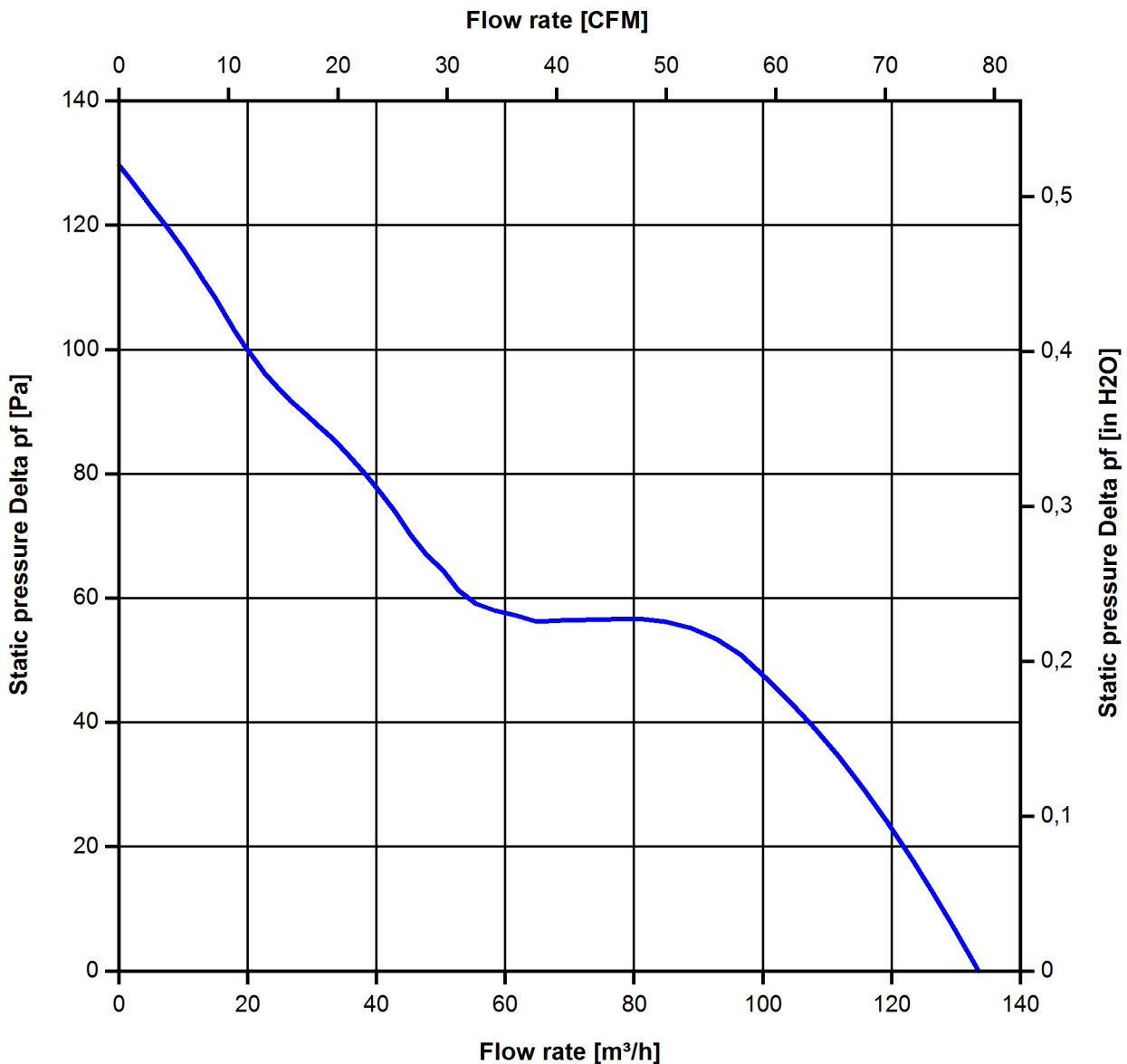





**3.6 Sound Data**

Measurement conditions: Sound pressure level: 1 meter distance between microphone and the air intake.  
 Sound power level: Acc. to DIN 45635 part 38 (ISO 10302)  
 Measured in a semianchoic chamber with a background noise level of  $L_p(A) < 5 \text{ dB(A)}$   
 For further measurement conditions see chapter aerodynamics.

a.) Operation condition:

|                              |                      |          |           |
|------------------------------|----------------------|----------|-----------|
| 4.350 1/min at free air flow | PWM 100 %; f: 25 kHz | f: 1 kHz | f: 30 kHz |
|------------------------------|----------------------|----------|-----------|

|   |                              |  |
|---|------------------------------|--|
| Optimal operating point   | 84 m <sup>3</sup> /h @ 51 Pa |  |
| Sound power level at the optimal operating point                | 6,0 bel(A)                   |  |
| Sound pressure level at free air flow, measured in rubber bands | 50 dB(A)                     |  |

**4 Environment**

**4.1 General**

|  |        |  |
|--|--------|--|
| Min. permitted ambient temperature TU min. | -20 °C |  |
| Max. permitted ambient temperature TU max. | 80 °C  |  |
| Min. permitted storage temperature TL min. | -40 °C |  |
| Max. permitted storage temperature TL max. | 80 °C  |  |

**4.2 Climatic Requirements**

|                       |   |  |
|-----------------------|---|--|
| Humidity requirements | humid heat, constant; according to DIN EN 60068-2-78, 14 days |  |
| Water exposure        | None  |  |
| Dust requirements     | None  |  |
| Salt fog requirements | None  |  |

Permitted application area:

The product is intended for use in sheltered rooms with controlled temperature and controlled humidity. Directly exposure to water must be avoided.

Pollution degree 1 (according DIN EN 60664-1)

There is either no pollution or it occurs only dry, non-conductive pollution. The pollution has no negative impact.

**4.3 Mechanical Requirements**

|                |  |  |
|----------------|--|--|
| severity level | Vibration (sinusoidal)   |  |
| 1 G            | Vibration (sinusoidal) in use<br>IEC 60068-2-6<br>Displacement / frequency range<br>Acceleration / frequency range<br>Sweep rate<br>Sweep cycles | Vibration (sinusoidal)<br>0,075 mm / 10-58, 58-10 Hz<br>1 G / 58-500-58 Hz<br>1 Oct./min<br>10 |

|                   |        |
|-------------------|--------|
| Duration          | 2 hrs. |
| Axes of vibration | 3      |

| severity level | stationary use           |  |  |
|----------------|--------------------------|--|--|
| 1              | storage / transportation | Random vibration not in use<br>IEC 60068-2-64<br>Frequency range / ASD<br><br>$G_{RMS}$<br>Axes of vibration<br>Test duration              | Random vibration<br>5 - 20 Hz : $1,0 \text{ m}^2 / \text{s}^3$<br>20 - 500 Hz : - 3 dB / Oct<br>0,91 G<br>3<br>3 x 5 h |
|                | storage / transportation | Bump not in use<br>IEC 60068-2-29<br>Shock spectrum<br>Acceleration<br>Duration<br>Number of bumps (+X, -X, -Y, +Y, -Z, +Z)<br>Total bumps | Bump<br>half sine<br>18 G<br>6 ms<br>100 in each direction<br>600  |
|                | stationary use           | Random vibration in use<br>IEC 60068-2-64<br>Frequency range / ASD<br><br>$G_{RMS}$<br>Axes of vibration<br>Test duration                  | Random vibration<br>5 - 20 Hz : $2,0 \text{ m}^2 / \text{s}^3$<br>20- 150 Hz : - 3 dB / Oct<br>0,83 G<br>3<br>3 x 5 h  |
|                | stationary use           | Bump in use<br>IEC 60068-2-29<br>Shock spectrum<br>Acceleration<br>Duration<br>Number of bumps (+X, -X, -Y, +Y, -Z, +Z)<br>Total bumps     | Bump<br>half sine<br>5 G<br>11 ms<br>100 in each direction<br>600  |

## 5 Safety

### 5.1 Electrical Safety

|  |                  |  |
|--|------------------|--|
| Dielectric strength<br>DIN EN 60950 (VDE 0805) and DIN EN 60335 (VDE 0700)<br>A.) Type test<br>Measuring conditions: After 48h of storage at 95% R.H. and 25°C.<br>No arcing or breakdown is allowed!<br>All connections together to ground. | 500 VAC / 1 Min. |  |
| B.) Routine test<br>Measuring conditions: At indoor climate.<br>No arcing or breakdown is allowed!<br>All connections together to ground.  | Not applicable   |  |
| Isolation resistance<br>Measuring conditions: After 48h of storage at 95% R.H. and 25°C measured with U=500 VDC for 1 min.   | RI > 10 MOhm     |  |
| Clearance / creepage distance  | 1,0 mm / 1,2 mm  |  |
| Protection class   | III              |  |

### 5.2 Approval Tests

|     |   |   |
|-----|---|---|
| CE  | EC Declaration of Conformity  | Yes   |
| EAC | Eurasian Conformity   | Yes   |
| UL  | Underwriters Laboratories   | Yes / UL507, Electric Fans  |
| VDE | Association for Electrical, Electronic and Information Technologies | Yes / Approval acc. to EN 60950 (VDE 0805) - Information technology equipment |
| CSA | Canadian Standards Association                                      | Yes / C22.2 No. 113 Fans and Ventilators                                      |
| CCC | China Compulsory Certification                                      | Not applicable  |

## 6 Reliability

### 6.1 General

|  |            |  |
|--|------------|--|
| Life expectancy L10 at TU = 40 °C                  | 60.000 h   |  |
| Life expectancy L10 at TU max.                     | 20.000 h   |  |
| Life expectancy L10 acc. to IPC 9591 at TU = 40 °C | 102. 500 h |  |

Copying of this document, and giving it others and the use or communication of the contents thereof, are forbidden without express authority. Offenders are liable to the payment of damages. All rights are reserved in the event of the grant of a patent or the registration of a utility model or design.

Schutzmerk nach DIN ISO 16016 beachten !  
Refer to protection notice DIN ISO 16016 !

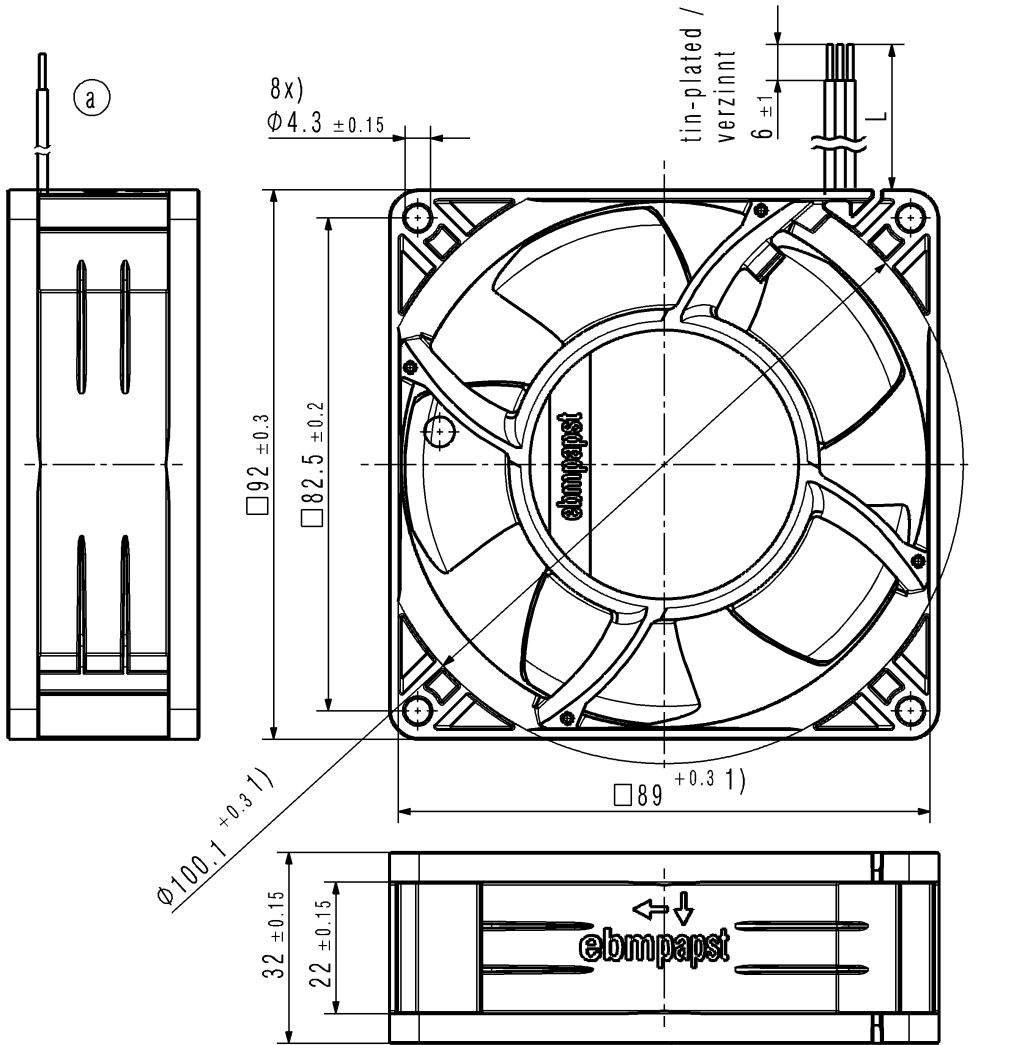

- 1) Maße für Montagewand / Dimensions for assembly wall
- Kein Axialspiel der Kugellager durch Federausgleich / no axial clearance of ball bearings due to a pre-load spring
  - Anzahl und Länge der Litzen siehe Produktspezifikation Blatt 1 / Number and length of the wires see design specification sheet 1

|  |  |                                   |  |   |  |                           |  |                               |  |
|--|--|-----------------------------------|--|---|--|---------------------------|--|-------------------------------|--|
| SAP-Status/State                       |  | Aend.-Nr./ Change-No.             |  | CATIA-System-Version/ CAD-Umgebung/ CATIA-System-Version/ CAD-Environment |  | Werkstoff / Material:     |  | Volumen / Volume (mm³):       |  |
| Tolerierung / Tolerances:              |  | 9293510100 CPR000A                |  | 3D-Referenzmodell / 3D-Referencemodel                                     |  | Artikel / Title:          |  | Gewicht / Mass (g):           |  |
| Allgemeintoleranzen / Gen. Tolerances: |  | Datum                             |  | Name  |  | Zchg.-Nr. / Drawing No:   |  | Ers.f.Zchg. / Replaces:       |  |
| ebmpapst                               |  | ebm-papst St.Georgen GmbH & Co KG |  | Dokumenttyp / Type of Document  |  | Teildokument (Blatt/Page) |  | Index / Index                 |  |
|  |  |                                   |  |   |  |                           |  | Format / Size: Massstab/Scale |  |