

Contact element FlatRear, 1 N/C, 1 N/A, front mount, spring clamp connection



Part no. M22-FK01SMC10
Catalog No. 180793
Eaton Catalog No. M22-FK01SMC10

Delivery program

Product range		Accessories
Single unit/Complete unit		Element
Basic function accessories		Self-monitoring contact elements
Approval		
Connection technique		Cage Clamp
Fixing		Front fixing
Description		The N/O is actuated when mounted on the pushbutton. Cage Clamp is a registered trademark of Wago Kontakttechnik GmbH/Minden, Germany
Contacts		
N/C = Normally closed		1 NC
Notes		= safety function, by positive opening to IEC/EN 60947-5-1
Actuator travel and actuation force as per DIN EN 60947-5-1, K.5.4.1		
	mm	5.5
Maximum travel	mm	5.8
Minimum force for positive opening	N	20
Contact sequence		
Contact travel diagram, stroke in connection with front element		
Degree of Protection		IP20
Connection to SmartWire-DT		no

Technical data
General

Standards		IEC 60947-5-1
Lifespan, mechanical	Operations	$\times 10^6$ > 1

Operating frequency	Operations/h		3600
Actuating force	n		4.5
Degree of Protection			IP20
Climatic proofing			Damp heat, constant, to IEC 60068-2-78 Damp heat, cyclic, to IEC 60068-2-30 Dry heat to IEC 60068-2-2
Ambient temperature			
Open	°C		-25 - +70
Storage	°C		- 40 - + 85
Mechanical shock resistance to IEC 60068-2-27 Shock duration 11 ms, half-sinusoidal	g		> 50
Terminal capacities	mm ²		
Solid	mm ²		2 x 1 (0.2 - 1.5) 2 x 1 (075 - 1.5) Can be plugged without tools
Flexible with ferrule	mm ²		2 x 1 (0.25 - 1) Use WAGO Variocrimp 4 crimping tool; please enquire for others
Solid or stranded	AWG		2 x 1 (24 - 16)

Contacts

Rated impulse withstand voltage	U _{imp}	V AC	4000
Rated insulation voltage	U _i	V	250
Overvoltage category/pollution degree			III/3
Max. short-circuit protective device			
Fuseless		Type	FAZ-B4
Fuse	gG/gL	A	4

Switching capacity

Rated operational current	I _e	A	
AC-15			
24 V	I _e	A	4
60 V	I _e	A	4
110 V	I _e	A	2
230 V	I _e	A	1.5
DC-13			
24 V	I _e	A	1.5
60 V	I _e	A	0.8
110 V	I _e	A	0.4
220 V	I _e	A	0.2

Auxiliary contacts

Rated conditional short-circuit current	I _q	kA	1
---	----------------	----	---

Design verification as per IEC/EN 61439

Technical data for design verification			
Operating ambient temperature max.		°C	-25
Operating ambient temperature max.		°C	70

Technical data ETIM 6.0

Low-voltage industrial components (EG000017) / Auxiliary contact block (EC000041)			
Electric engineering, automation, process control engineering / Low-voltage switch technology / Component for low-voltage switching technology / Auxiliary switch block (ec@ss8.1-27-37-13-02 [AKN342010])			
Number of contacts as change-over contact			0
Number of contacts as normally open contact			1
Number of contacts as normally closed contact			1
Rated operation current I _e at AC-15, 230 V		A	1.5
Type of electric connection			Spring clamp connection
Model			Top mounting
Mounting method			Front fastening

Dimensions

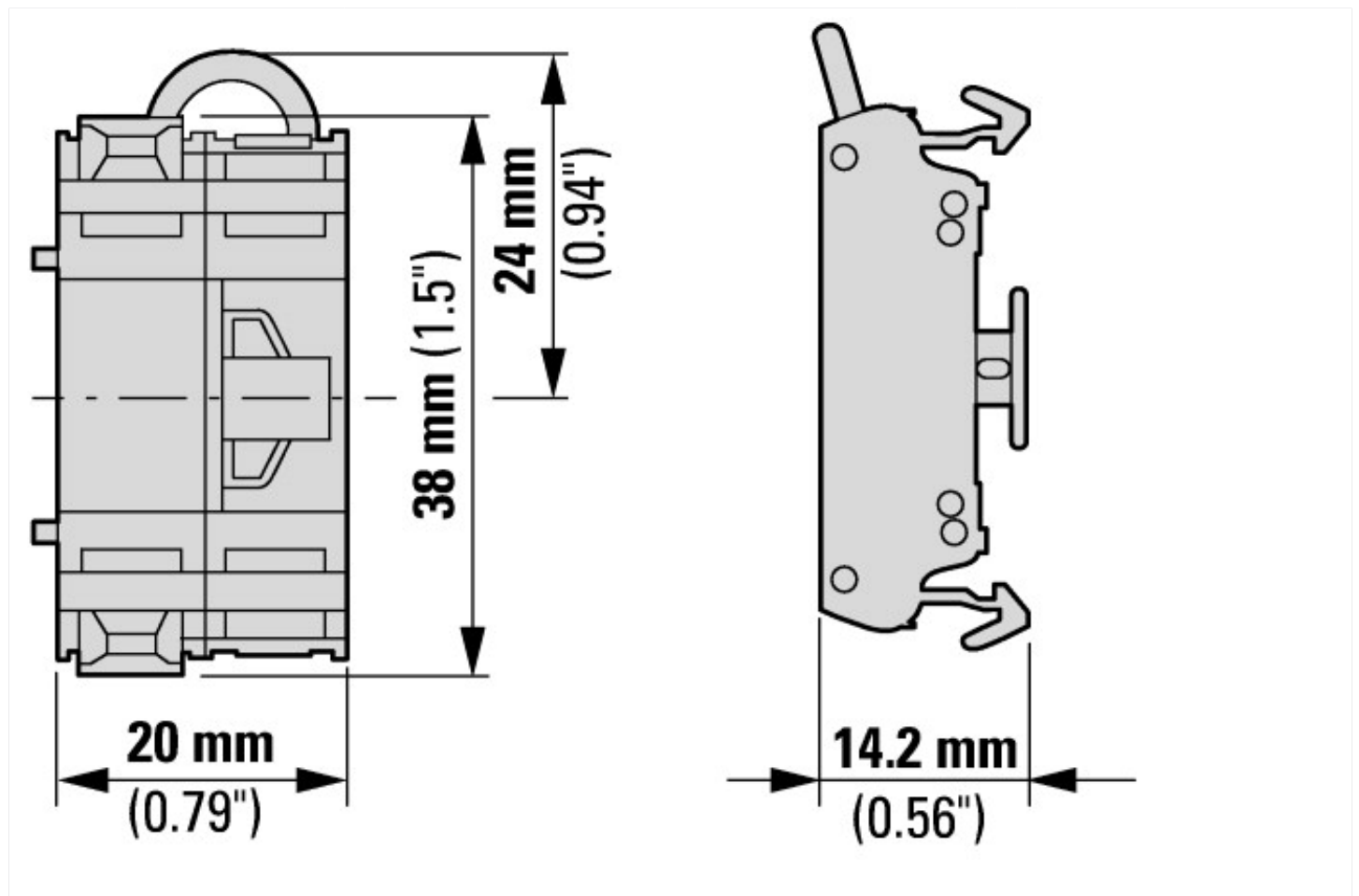

Additional product information (links)

DGUV Test Mark Customer Information

http://www.dguv.de/medien/dguv-test-medien/_pdf_zip_doc_ppt/agb-und-pzo/dguv_test_zeichen_infoblatt_kunden.pdf